

N39200 Series High-accuracy Dual-channel Programmable DC Power Supply

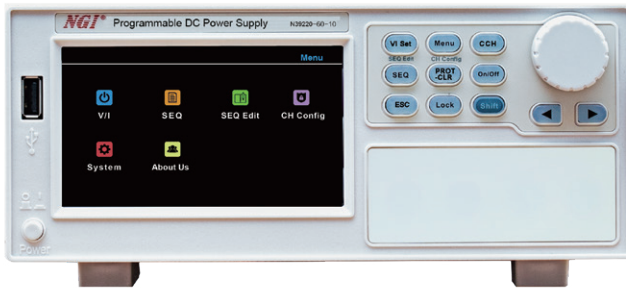

Product Introduction

N39200 series is a high-accuracy & dual-channel programmable DC power supply, available for benchtop use. N39200 standalone supports 2 channels output, with each channel isolated. Both local operation on front panel and remote control on a computer are supported. N39200 can be widely used in lab test, system integration test, production aging line, etc.

Main Features

- ▶ Voltage range: 60V/150V
- ▶ Current range: 4A/8A/10A/20A
- ▶ Power range: 200W/400W/600W
- ▶ CC&CV priority function
- ▶ Multiple protections: OVP, OCP, OTP and short circuit
- ▶ High definition touch screen
- ▶ User-friendly interface
- ▶ LAN port and RS232 interface
- ▶ Dual LAN ports design
- ▶ Single device with 2 channels, each channel isolated

Dual channels, compact size and light weight

N39200 series adopts 2U and half 19 inch design, with 2 channels in a single device. Each channel is isolated. One device can support 2-station test simultaneously, which simplifies the test platform and improves test efficiency.

UI flat icons

UI flat icons offer convenient and quick operation.

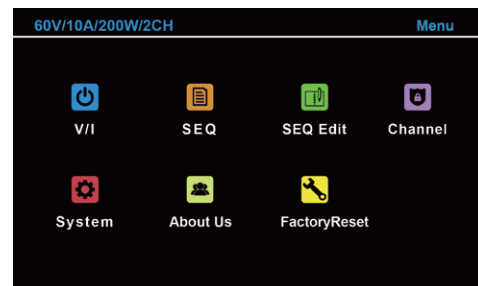

Virtual keypad

N39200 is designed with a virtual keypad for parameters input.

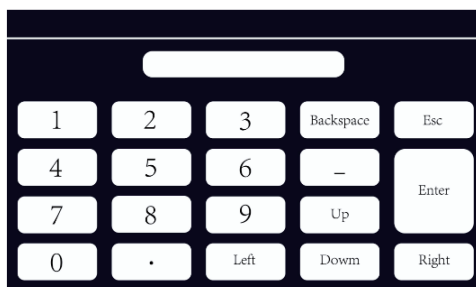

SEQ mode

SEQ mode allows setting of output voltage, output current and dwell time for single step.

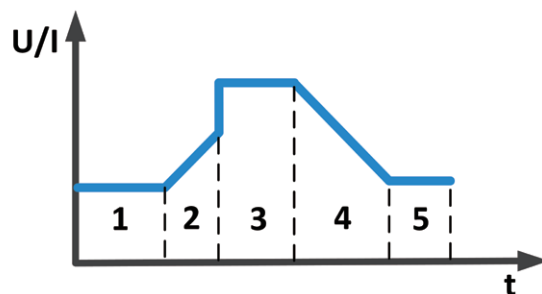

Cascade mode for power expansion

N39200 supports two channels parallel mode internally. Under parallel mode, the output voltage remains the same. The output current and power will be doubled.

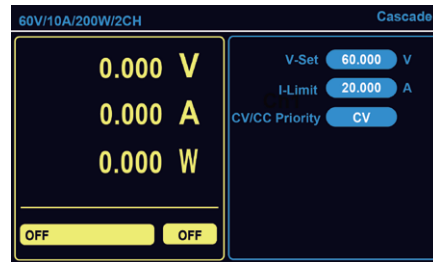
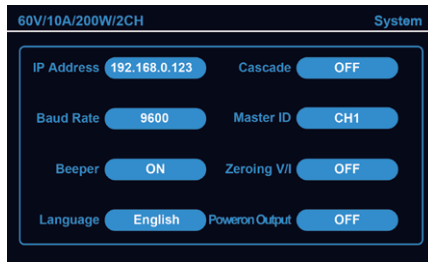

CC&CV priority function

N39200 has the function of selecting priority of voltage-control loop or current-control loop, which enables N39200 to adopt the optimal test mode for different DUTs, and thus protect the DUT.

As shown in figure one, when the DUT requires reducing voltage overshoot during test, such as supplying power to a low-voltage processor or FPGA core, voltage priority mode should be selected to obtain fast and smooth rise voltage.

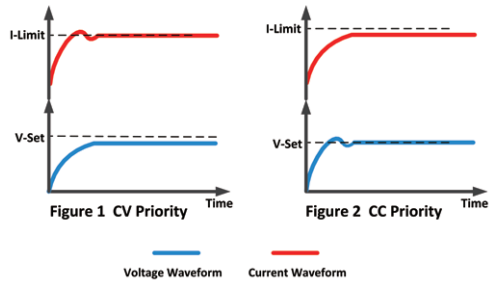

As shown in figure two, when the DUT requires reducing current overshoot during test, or when the DUT is with low impedance, such as battery charging scenario, current priority mode should be selected to obtain fast and smooth rise current.

Dual LAN ports for multiple devices control

N39200 is equipped with two LAN ports, which can support multiple devices control for quick adjustment and test.

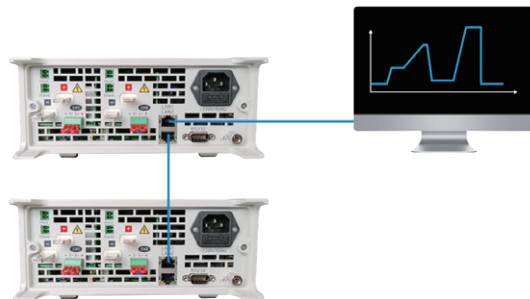

Product Dimension

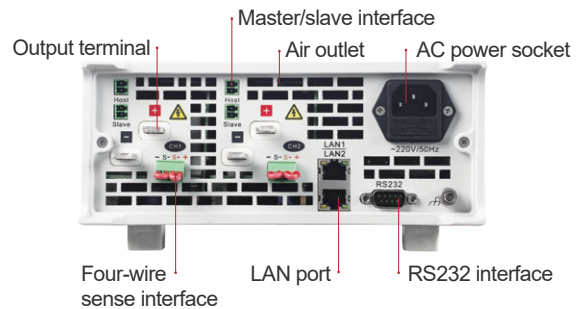
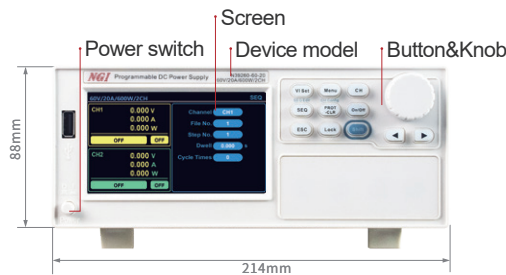

Technical Data Sheet

Model	N39220-60-10	N39240-60-20	N39260-60-20	N39220-150-04	N39240-150-08	N39260-150-08
Voltage	60V/CH			150V/CH		
Current	10A/CH	20A/CH	20A/CH	4A/CH	8A/CH	8A/CH
Power	200W/CH	400W/CH	600W/CH	200W/CH	400W/CH	600W/CH
Channels	2CH					
CV Mode						
Range	0~60V			0~150V		
Setting Resolution	1mV			10mV		
Setting Accuracy (23±5℃)	0.05%+0.1%F.S.					
Setting Temperature Coefficient (0-40℃)	50ppm /℃					
Readback Resolution	1mV			10mV		
Readback Accuracy (23±5℃)	0.05%+0.1%F.S.					
Readback Temperature Coefficient (0-40℃)	50ppm /℃					
CC Mode						
Range	0~10A	0~20A	0~20A	0~4A	0~8A	0~8A
Setting Resolution	1mA					
Setting Accuracy(23±5℃)	0.1%+0.1%F.S.					
Setting Temperature Coefficient (0-40℃)	50ppm /℃					
Readback Resolution	1mA					
Readback Accuracy(23±5℃)	0.1%+0.1%F.S.					
Readback Temperature Coefficient (0-40℃)	50ppm/℃					
Output Noise & Ripple(20Hz-20MHz)						
Voltage Ripple	250mVp-p			300mVp-p		
	20mVrms			25mVrms		
Line Regulation	≤0.015%(Voltage)					
Load Regulation	≤0.03%(Voltage)					
Voltage Rise Time (no load)	≤50ms					
Voltage Fall Time (no load)	≤50ms					
Others						
Interface	LAN/RS232					
AC Input	Single phase, 220V AC±10%, frequency 47Hz~63Hz					
Temperature	Operating temperature: 0℃~40℃, storage temperature: -20℃~60℃					
Operating Environment	Altitude <2000m, relative humidity: 5%~90%RH(non-condensing), atmospheric pressure: 80~110kPa					
Net Weight	Approx. 7 kg					
Dimension	2U, 88.0(H)*214.0(W)*546.0(D)mm					

Note 1: For other specifications, please contact NGI.

Note 2: All specifications are subject to change without notice.