



[www.odacore.com](http://www.odacore.com)

---

# Programmable DC Power Supply

# **PT Series**

## User Manual

Manual Part NO. 018PT-2.0



## Legal Notices

© ODA Technologies Co., Ltd. 2008

No part of this document may be photocopied, reproduced, or translated to another language without the prior agreement and written consent of ODA Technologies Co., Ltd. as governed by Republic of Korea and international copyright laws.

## Warranty Certification

The material contained in this document is provided “as is,” and is subject to being changed, without notice, in future editions. Further, to the maximum extent permitted by applicable law, ODA disclaims all warranties, either express or implied, with regard to this manual and any information contained herein, including but not limited to the implied warranties of merchantability and fitness for a particular purpose. ODA shall not be liable for errors or for incidental or consequential damages in connection with the furnishing, use, or performance of this document or of any information contained herein. Should ODA and the user have a separate written agreement with warranty terms covering the material in this document that conflict with these terms, the warranty terms in the separate agreement shall control.

## Assistance

This product comes with the standard product warranty. Warranty options, extended support contacts, product maintenance agreements and customer assistance agreements are also available. Contact your nearest ODA Technologies Sales and Service office for further information on ODA Technologies' full line of Support Programs. Refer to below information.

www.odacore.com  
oda@odacore.com  
+82-2-1800-8644

## Waste Electrical and Electronic Equipment

The affixed product label (see right) indicates that you must not discard this electrical/electronic product in domestic household waste. Do not dispose in domestic household waste. To return unwanted products, contact our local ODA distributors, or call us for more information.



## Manual Editions

Manual Part Number: 018PT-2.0      Edition 2, February, 2018      Printed in ROK  
Reprints of this manual containing minor corrections and updates may have the same printing date.  
Revised editions are identified by a new printing date.



## Safety Notices

The following general safety precautions must be observed during all phases of operation of this instrument. Failure to comply with these precautions or with specific warnings or instructions elsewhere in this manual violates safety standards of design, manufacture, and intended use of the instrument. ODA Technologies assumes no liability for the customer's failure to comply with these requirements.

### General

Do not use this product in any manner not specified by the manufacturer. The protective features of this product may be impaired if it is used in a manner not specified in the operation instructions.

### Do Not Modify the Instrument

Do not install substitute parts or perform any unauthorized modification to the product. Return the product to an ODA Sales and Service Office for service and repair to ensure that safety features are maintained.

### Ground the Instrument

This product is a Safety Class 1 instrument (provided with a protective earth terminal). To minimize shock hazard, the instrument chassis and cover must be connected to an electrical ground. The instrument must be connected to the ac power mains through a grounded power cable, with the ground wire firmly connected to an electrical ground (safety ground) at the power outlet. Any interruption of the protective (grounding) conductor or disconnection of the protective earth terminal will cause a potential shock hazard that could result in personal injury.

### In Case of Damage

Instruments that appear damaged or defective should be made inoperative and secured against unintended operation until they can be repaired by qualified service personnel.

### Before Applying Power

Verify that all safety precautions are taken. Make all connections to the unit before applying power. Note the instrument's external markings described under "Safety Symbols"

### CAUTION

A **CAUTION** notice denotes a hazard. It calls attention to an operating procedure, practice, or the like that, if not correctly performed or adhered to, could result in damage to the product or loss of important data. Do not proceed beyond a **CAUTION** notice until the indicated conditions are fully understood and met.

### Fuses

The instrument contains an internal fuse, which is not customer accessible.

### WARNING

A **WARNING** notice denotes a hazard. It calls attention to an operating procedure, practice, or the like that, if not correctly performed or adhered to, could result in personal injury or death. Do not proceed beyond a **WARNING** notice until the indicated conditions are fully understood and met.







### Do Not Operate in an Explosive Atmosphere





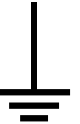
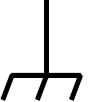



Do not operate the instrument in the presence of flammable gases or fumes.

### Do Not Remove the Instrument Cover

Only qualified, service-trained personnel who are aware of the hazards involved should remove instrument covers. Always disconnect the power cable and any external circuits before removing the instrument cover.

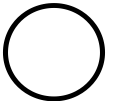
## Safety Symbol

	Direct current
	Both direct and alternating current
	Earth (ground) terminal
	Frame or chassis terminal
<b>N</b>	Neutral conductor on permanently installed equipment
	On supply
	Standby supply. Unit is not completely disconnected from ac mains when switch is off
	Out position of a bi-stable push switch
	Caution, hot surface

	Alternating current
	Three phase alternating current
	Protective earth ground terminal.
	Terminal is at earth potential.
	Line conductor on permanently installed equipment.
	Off supply
	In position of a bi-stable push switch
	Caution, risk of electric shock
	Caution, refer to accompanying documents

# CONTENTS

<b>1. General Information</b> .....	6
<b>1-1. Characteristics</b> .....	6
Feature	
Remote Interface Characteristics	
Calibration	
Factory Function	
Self Test Characteristics	
<b>1-2. Accessories and Options</b> .....	7
Accessories	
Options	
<b>1-3. . Inspecting the Unit</b> .....	8
Instrument Check	
Electrical Check	
<b>1-4. Operating</b> .....	8
<b>1-5. Check Before Power On</b> .....	9
Output Terminal Check	
Power Cord Check	
Input AC Power Line Check	
<b>1-6. Check After Power On</b> .....	11
Display Procedure on the LCD	
Default Setting Values	
<b>1-7. Installation</b> .....	12
Cooling	
Bench Operation	
Rack Mounting	
<b>2. Front Panel, Rear Panel Composition</b> .....	14
<b>2-1. Front Panel Front-Panel Setting</b> .....	17
<b>2-2. Rear Panel Composition</b> .....	18
<b>2-3. Output Check</b> .....	20
Voltage Output Check	
Current Output Check	
<b>3. Front Panel Operating</b> .....	21
Over view .....	21
<b>3-1. Constant Voltage Operating(CV)</b> .....	22
<b>3-2. Constant Current Operating(CC)</b> .....	23

---

<b>3-3. Remote Voltage Sensing</b>	24
CV Regulation	
Output Rating	
Output Noise	
Stability	
Remote Voltage Sensing Connection	
<b>3-4. Programming Over Voltage Protection(OVP)</b>	26
<b>3-5. Programming Over Current Protection(OCP)</b>	29
<b>3-6. Programming Under Voltage Limit(UVL)</b>	31
<b>3-7. Programming Over Voltage Limit(OVL)</b>	32
<b>3-8. Programming Under Current Limit(UCL)</b>	33
<b>3-9. Programming Over Current Limit(OCL)</b>	34
<b>3-10. Key Lock</b>	35
<b>3-11. IO/Local</b>	36
RS232C Setting	
RS232C Configuration	
RS485 Setting	
RS232C,RS485 Configuration	
TCP/IP Setting(Optional)	
Delimiter	
Response	
<b>3-12. Limit Display</b>	45
<b>3-13. Store</b>	46
<b>3-14. Recal</b>	47
<b>3-15. Output ON/OFF</b>	48
<b>3-16. Error Message Display</b>	49
<b>4. CALIBRATION</b>	50
<b>4-1. Charac</b>	50
<b>4-2. Preparation for Calibrator</b>	50
<b>4-3. Equipment required for Calibration</b>	51
<b>4-4. Technic of Calibration</b>	51
Instruments Connection Drawing	
Electronic Load	
Current-Monitoring Resistor(shunt)	
DVM(Digital Volt Meter)	
Programming	
Measuring Point	

---

---

<b>4-5. Using Front Panel Calibrator</b> .....	53
Calibration Key Structure	
Voltage Calibration	
Current Calibration	
<b>4-6. Remote Interface Calibration</b> .....	57
Instruments Connection	
Remote calibration Command Procedure	
Voltage Calibration	
Current Calibration	
<b>5. Factory</b> .....	59
<b>5-1. Characteristic</b> .....	59
<b>5-2. Factory Key Structure</b> .....	59
<b>5-3. User-Mem Clear</b> .....	60
USER-MEM CLEAR Operating	
<b>5-4. Last State</b> .....	61
LAST STATE Operating	
<b>5-5. AUTO CURSOR MV</b> .....	62
AUTO CURSOR MV(Moving) Operating	
<b>5-6. AUTO KEY LOCK</b> .....	63
AUTO KEY LOCK operating	
<b>5-7. OVP USE</b> .....	64
OVP USE	
<b>5-8. OCP USE</b> .....	65
OCP USE	
<b>5-9. ADC SAMPLING</b> .....	66
ADC SAMPLING	
<b>5-10. CAL-RESTORE</b> .....	67
CAL-RESTORE Operating	
<b>5-11. CAL-BACKU</b> .....	67
CAL-BACKUP Operating	
<b>5-12. CAL-DEFAULT</b> .....	68
CAL-DEFAULT Operating	
<b>5-13. LOAD DEFAULT</b> .....	68
LOAD DEFAULT Operating	
<b>6. SCPI Command</b> .....	69
<b>6-1. Commands Syntax</b> .....	69

---

---

6-2. Commands	69
Output Setting Commands	
Measurement Commands	
Calibration Commands	
Factory Commands	
System Commands	
6-3. Apply Commands	71
6-4. Output V/I Setting & Operating Commands	71
6-5. Measure Commands	76
6-6. Calibration Commands	77
6-7. Factory Commands	77
6-8. System Commands	80
7. Error Messages	83
7-1. Operating Error	83
7-2. Hardware Error	83
7-3. Remote Calibration Error	83
7-4. Calibration Error	85
7-5. Nonvolatile Memory Check	85
7-6. Interface Commands Error	86
8. Specifications	87
9. System	88
10. Cautions	89



# 1. General Information

## 1-1. Feature

PT Series are high-performance and high-efficiency programmable DC power Supply  
Which has 200W~ 400W volume with RS-232C, RS-485 interface based on SCPI Protocol.

### General Feature

- Easy-to-use knob control settings.
- Output ON/OFF key.
- Front panel key lock function
- Alarm beep when events occur.
- Excellent precise and high resolution.
- Built-in Remote Sensing for Load Voltage(V-Sensing)
- O.V.P(Over Voltage Protection) / O.C.P(Over Current Protection) mode supplied.
- U.V.L(Voltage under level)/O.V.L(Voltage over level) level value setting function.
- Excellent load and line regulation.
- Memory(operating state of voltage, current, OVP,OCP) store and recall available up to 10
- Save and confirm up to 10 error messages.
- High-efficient output of 80%~90%.

### Remote Interface characteristics

- Supply various interface.(RS232C, RS485, USB, TCP/IP(option))
- adoptend SCPI(Standard Commands for Programmable Instruments) command.
- High speed setting & measurement
- Programmed in abundant commands in the instrument.
- Easy interface setting by front panel key of "I/O config".
- Technical realization of products insulation & Floating Logic.
- Built-in the checking of SCPI programming grammar error.

### Calibration

- No need of opening cover of instrument in order to calibrate and adopted software calibration.
- Easy calibration operating by using independence or PC interface.

### Factory Function

- Initial function of 10 user memory.
- Last state(before turn off the power) memory store and recall function.
- The function of "Auto Key Lock & Auto Cursor Move" that prevents operator's mistake.
- OVP & OCP disable or disable setting function.
- LCD display speed control function of V/I value by using "ADC Sampling" function.
- Calibration restore function.
- Calibration backup function.

### Self Test Characteristics

- Front panel Test
- Remote interface Test
- Memory date verification test
- ADC H/W error Test
- Unregulated state test
- ADC/DAC calibration verification test

## 1-2. Accessories and Options

### Accessories

- 1.5M power code 1pc.
- Operating Manual 1pc.
- Demo version software is in homepage.  
<http://www.odacore.com>

### Option

- RS232C Cable 1M, 2M, 4M
- RS485 Cable 2/4/8-Channel 1M, 2M, 4M, 10M
- AC Input Cable (Special order type)
- Output Cable (Special order type)

## 1-3. Inspecting the Unit.

When you receive your power supply, inspect it for any obvious damage that may have occurred during shipment. If any damage is found, notify the carrier and the nearest ODA Sales Office immediately. Warranty information is shown in the front of this manual. Keep the original packing materials in case the power supply has to be returned to ODA Technologies in the future. If you return the power supply for service, attach a tag identifying the owner and model number. Also include a brief description of the problem.

### Mechanical Check

- Check the broken key, encoder switch, power switch.
- Check the panel surfaces are free of dents and scratches.
- Check the broken rear output terminals.
- Check the cabinet is free of scratches.
- Check the LDC display is not scratched or cracked.

### Electrical Check

- When turning on the power, check the alarm sound.  
If the alarm sounds, the instrument has the error during self-testing itself.  
Error checking, press the error key and conform error code.  
More information about error code, refer to "7.Error Messages".  
*About Self-test, refer to "1-6. Check after Power On".*
- Check the model Number is matched with displayed model number.
- After, it shows "\*\*OUTPUT OFF\*\*" message, verifies to a high level of confidence that the power supply is operating in accordance with its specifications.

#### Note

---

Service Center : 82-70-5032-2926/2928, sales2@odacore.com  
Home page : [www.odacore.com](http://www.odacore.com)

---

## 1-4. Operating Conditions

This instrument is designed for following environmental conditions in order to use optimized condi

- Environmental Temperature : 0 ~ 40°C
- Relative Humidity :  $\leq 80\%$  RH
- Operating altitude : <2000m.pollution degree II
- No vibration.
- ■ Avoid the electricmagnetic field.

## 1-5. Check Before Power On

### Output Terminal Check

- Check the rear panel outputs for voltage sensing and rear main outputs.

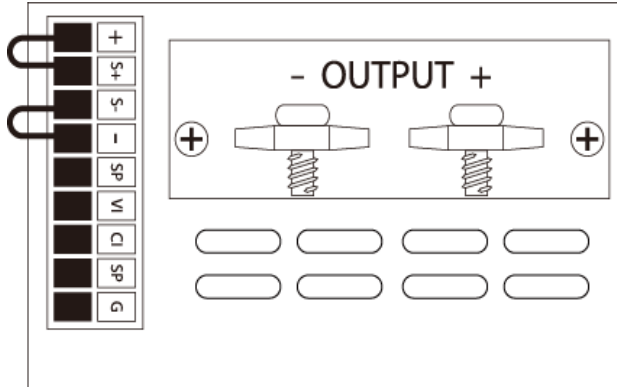

#### **WARNING**

Floating the power supply output more than  $\pm 60$  Vdc from the chassis presents an electric shock hazard to the operator. Do not float the outputs more than  $\pm 60$  Vdc when metal shorting material or wire without insulation are used to connect the (+) output to the (+) sense and the (-) output to the (-) sense terminals.

#### **WARNING**

Outputs can be floated to maximum of  $\pm 240$  Vdc provided that the metal shorting wire without insulation are either replaced with insulated conductors or they are removed from the terminals so there is no operator access to the output conductors without insulation. All field wiring insulation must be adequate for the voltage present.

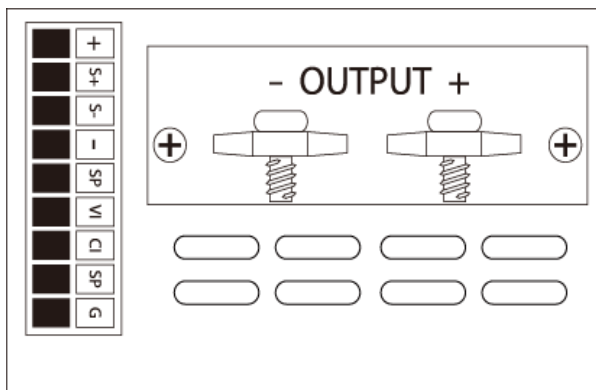

<Figure 1-2>

## Check Powercode

- Power code in package is 3-Wire Ground type.  
if you use another power code , use the ground type. GND of product.

## Input AC Power Line Check

- This product is designed for Single phase AC 110~220V+\_10% / 50~60Hz.
- in order to prevent the instrument severe damage from overload, fuse is built-in (1U, 2U products) or braker(3U products) is installed rear side. If fuse also is

*broken or braker is turned down repeatedly when power turns on, check the input power line or broken braker and then call to nearest ODA Technologies A/S Center*

## 1-6. Check After Power On.

The power-on test includes an automatic self-test that checks the internal microprocessors and allows the user visually to check the display. You will observe the following sequence on the display after pressing the front panel power switch to on. And also keep the ex-remote and voltage value is zero and current value is max value. OVP & OCP level are set to maximum output value of instrument capacity and it is under the vigilance.

### Display Procedure on the LCD

- Display "ODA Technologies".
- Display "PT-Series Ver1.3"
- Annunciators of ERR, LMT, RMT, LOCK on front side are lit and go off clockwise from. *CV & CC annunciators are not applied.*

During displaying above procedure, the instrument is initialized by stored in non volatile memory.

- Also the instrument runs automatic self-test below mentioned.

Front panel Test	Connection test between front panel and connector.
Remote interface Test	Check remote interface for PC communication.
Memory Data Test	Check product information and related setting.
ADC H/W Error Test	Check error on ADC control condition.
UnRegulated State Test	Check output voltage floating state.
ADC/DAC Calibration Test	Check ADC & DAC Calibration data state.

If the error occurs, alarm beeps and the error code is saved to volatile memory automatically. You can read the error code by pressing error key.  
*About error code explanation, refer to "7. Error Messages".*

### Default Setting Values (Last state Mode is under the Disable state)

- |  |  |
|--|--|
| ■ OVP : OVP value is max, state is ON.   | ■ Remote Interface : Keep the Previous State |
| ■ OCP value is max, state is ON.         | ■ State after self-test : "**OUTPUT OFF**"   |
| ■ UVL : 0V                               | ■ Cursor location : Default voltage select   |
| ■ OVL : Limit setting maximum value.     | Voltage : 1V                                 |
| ■ UCL : 0A                               | Current : 100mA if current is under 5A.      |
| ■ OCL : Limit setting maximum value.     | In case of under 50A : 1A                    |
| ■ Output Voltage : 0V                    | In case of under 100A : 10A                  |
| ■ Output Current : Limit setting maximum | ■ KEY LOCK : OFF                             |

#### Note1

Remote Interface default is RS232C and the rate is set to 9600 baud when the power supply is shipped from the factory. TCP/IP Module is optional and built in type. When ordering, please re

#### Note2

In case of "Last State", it is disable when the power supply is shipped from the factory. If you want to use this function, it is able to use in "Factory Mode". Refer to "5-4. Last State"

## 1-7. Installation.

### Cooling

- The power supply can operate without loss of performance within the temperature range

power supply by drawing air through the rear panel and exhausting it out the sides. Using an ODA rack mount will not impede the flow of air.

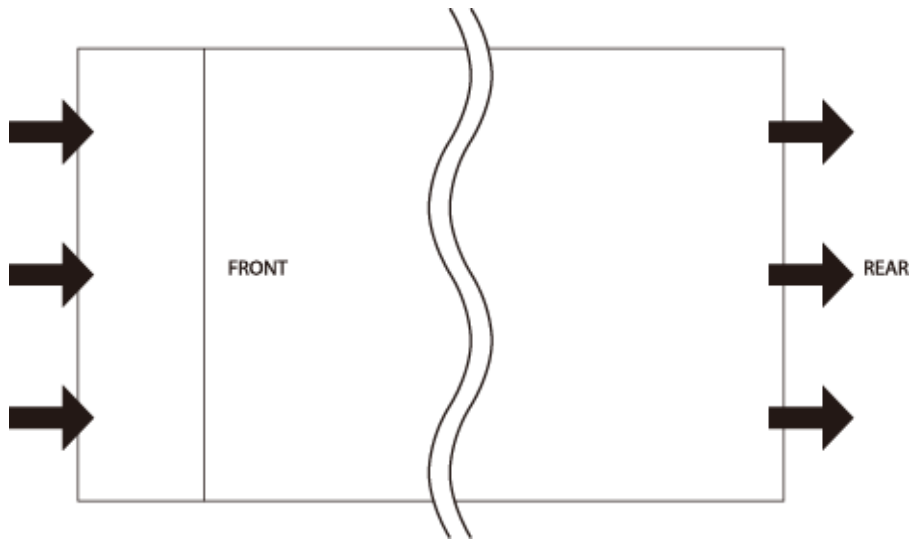

<Figure. 1-4 Bottom view>

### Bench Operation

- Your power supply must be installed in a location that allows sufficient space at the sides and rear of the power supply for adequate air circulation.

## 2. Front Panel, Rear Panel Composition & Function.

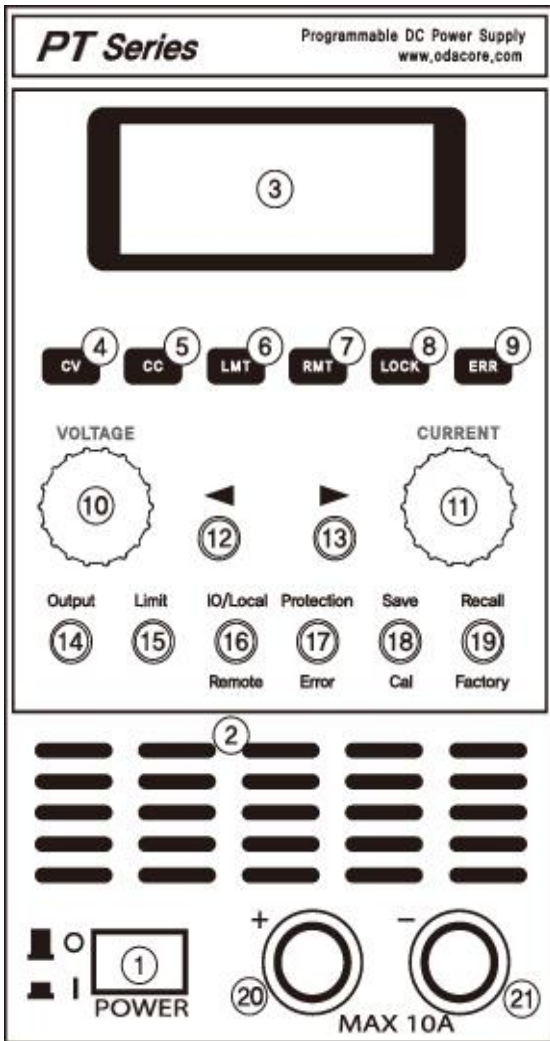

1	POWER switch
2	Ventilation slit
3	8 Character, two line LCD Display
4	CV Mode Lamp
5	CC Mode Lamp
6	Limit Display Lamp
7	Remote Interface Lamp
8	Key Lock Lamp
9	Error Lamp
10	Voltage Encoder Knob
11	Current Encoder Knob
12	Volt Cursor or Menu Change Key
13	Curr Cursor or Menu Change Key
14	Output ON/OFF Key
15	Volt/Curr Setting Limit Display Key
16	IO/Local Setting and Error Display Key
17	Protection Setting and Front-panel Lock Ke
18	Store or Calibration Key
19	Recall or Factory Key
20	"+" DC Output terminal for measurement
21	"-" DC Output terminal for measurement



**1. POWER switch.**

The power supply is turned on or off by this switch. It is adopted by following power supply's capacity.

**2. Ventilation slit.**

Air flow flows from front ventilation slit to rear ventilation slit compulsorily.

**3. 16Character LCD Display.**

Voltage/current and , all kinds menu/message displayed.

**4. CV Mode Lamp.**

The power supply is in constant voltage mode.

**5. CC Mode Lamp.**

The power supply is in constant current mode.

**6. Limit Display Lamp**

When the instrument is under the setting of Volt/Curr, LED is lit. If the device is output on state, LED is turned off.

**7. Remote Interface Lamp**

When received the remote control signal from PC, PLC and etc, it lights and automatically, front panel keys are under "Key Lock" state.

**8. Key Lock Lamp**

If Key lock lamp is turned on, front panel keys are not working.

**9. Error Lamp**

Error occurs, LED is lit. After checked all errors, LED is turned off.

**10. Voltage Encoder Knob.**

Adjusts the output voltage, the over-voltage protection level, the under-voltage limit and numeric value changing of other menu.

**11. Current Encoder Knob.**

Adjusts the output current, the over-current protection level, the under-current limit and numeric value changing of other menu.

**12. Volt Cursor or Menu Change Key.**

Move the under bar digit to the left about voltage. It also is used to move to next menu when selected menu mode.

**13. Curr Cursor or Menu Change Key.**

Move the under bar digit to the right about current. It also is used to move to next menu when selected menu mode.

**14. Output ON/OFF Key.**

Enables or disables the power supply output. This key toggles between on and off.

**15. Volt/Curr Setting Limit Display Key.**

Shows voltage and current limit values on the display and allows knob adjustment for setting limit values with lighting LMT lamp. One more press this key during 1 sec, return to previous state. You only see the setting value not just real output value.

**16. IO/Local Setting and Error Display Key**

Configures the power supply for remote interfaces(Choose RS232C, RS485)  
This key can be used to change to Local Mode from Remote Interface state.  
Displays error codes generated during operation and self-test.

**17. Protection Setting and Front-panel Lock Key**

Enables or disables the OVP/OCP/UVL/OVL/UCL/OCL protection function, sets trip voltage level, and clears the overvoltage condition. Also during 1 sec press this key, you can lock front panel operating with lighting LOCK lamp. One more press this key during 1 sec, clear the lock key.

**18. Store or Calibration Key.**

Stores an operating state(voltage, current, OVP, OCP and other state) in location "1", "2", "3" or another number / enables calibration mode with pressing this key and put the AC power on.

**19. Recall or Factory Key.**

Recalls an operating state(voltage, current, OVP, OCP and other state) in location "1", "2", "3" or another number / enables factory mode(Memory Initializing, ,Auto Cursor Move, Auto Key Lock, OVP Disable, OCP Disable, ADC Sampling, Calibration Restore, Calibration Backup, Calibration Factory Default Recover and etc) with pressing this key and put the AC power on.

## 2-1. Front-Panel Setting

You can set the voltage and current limit values from the front panel using the following method.

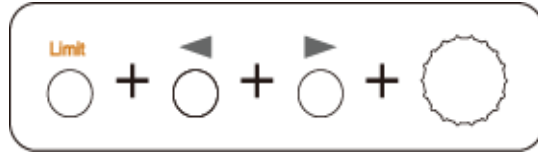

1. Confirm the display of "OUTPUT OFF" on the LCD after turning on the power supply.
2. Press the "Limit Display" key to show the limit values on the display.
3. Left cursor key is for voltage setting from fine to course, also right cursor key is for current setting from course to fine.
4. About both of encoder knob, left encoder is for voltage value increasing or decreasing. Right encoder is for current value increasing or decreasing.
5. in order to increase the volt/curr limit value, turn the encoder clockwise.  
in order to decrease the volt/curr limit value, turn the encoder counter clockwise.
6. Confirm the change of setting value at LCD display.
7. in order to output the setting voltage & current, press "OUTP ON/OFF" key.

### Note1

If the power-on self-test fails, the ERROR annunciator turns on and then press the "Error Key" in order to confirm the error code.

About error code, refer to "7. Error Messages".

### Note3

When the instrument is operating under the remote interface, the power supply can not be both a listener and a talker. in order to control by front panel key, press the "IO/Local Key" to local control after stopped the remote Interface operating.

## 2-2. Rear Panel Composition.

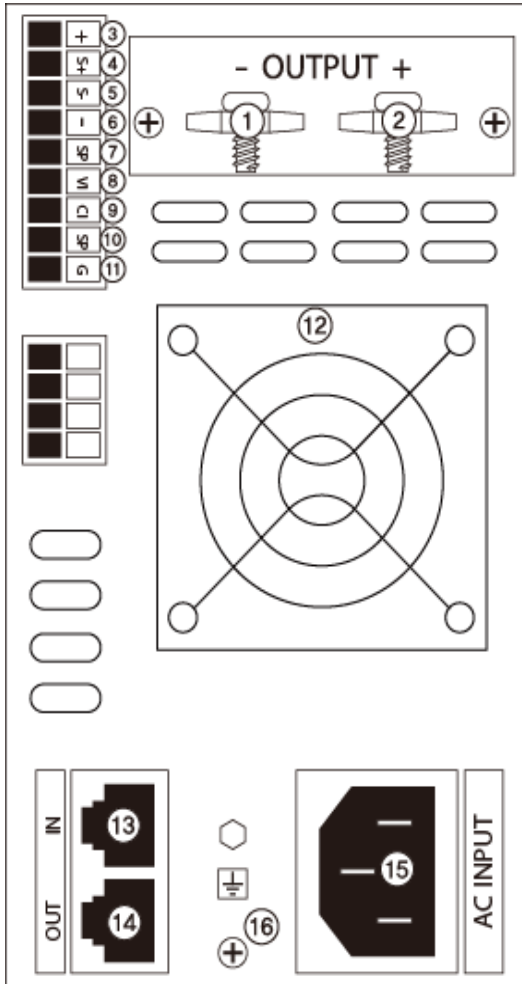

- 1 - Output Bus Bars
- 2 + Output Bus Bars
- 3 + Output connector
- 4 + Voltage Sensing Input Connector
- 5 - Output connector
- 6 - Voltage Sensing Input Connector
- 7 +12V Positive Voltage
- 8 Voltage Control(0~10V)
- 9 Current Control(0~10V)
- 10 +12V Positive Voltage
- 11 Analog Ground
- 12 DC FAN
- 13 RS232C,RS485 Interface Port
- 14 RS485 Interface Port
- 15 AC Input
- 16 Ground Terminal

### 1. - Output Bus Bars

Negative DC power output bus bar of power supply.

### 2. + Output Bus Bars

Positive DC power output bus bar of power supply.

### 3. + Output Connector

Connect to + Voltage Sensing input Connector when you're not using Voltage Sensing.

### 4. + Voltage Sensing Input Connector

Input terminal of positive output voltage sensing.

By this connector, you can supply the precise Voltage into load.

### 5. - Output Connector

Connect to + Voltage Sensing input Connector when you're not using Voltage Sensing.

### 6. - Voltage Sensing Input Connector

Input terminal of positive output voltage sensing.

By this connector, you can supply the precise Voltage into load.

**7. +12V Positive Voltage**

Connec to basis Voltage(VI) and Current(CI) when you'r not using Analog Control.

**8. Voltage Control(0~10V)**

Ratio control for output voltage of power supply by 0~ 10V input.

**9. Current Control(0~10V)**

Ratio control for output current of power supply by 0~ 10V input.

**10. +12V Positive Voltage**

Connec to basis Voltage(VI) and Current(CI) when you'r not using Analog Control.

**11. Analog Ground**

Common ground for VI/CI input terminal.

**12. DC FAN**

A fan cools the power supply by drawing air through the front panel air slit and side air slit and exhausting it out the rear air slit.

**13. RS232C,RS485 Interface Port**

Serial port of Personal Computer that is standard.

One on one communication with external controller(for examples, PC,PLC and etc).

**14. RS485 Interface Port**

The RS485 interface port on the rear panel connects your power supply to the computer and other RS485 devices(DMM, scope, function, spectrum and etc). It is type of parallel communicaton interface.

**15. AC Input**

When overloaded, the method of cut the AC power line is to break the AC input fuse.

If turns on the main power switch and the power supply is not working, check the fuse broken or not.

## 2–3. Output Check

The following procedures check to ensure that the power supply develops its rated outputs and properly responds to operation from the front panel. For complete performance and verification tests, refer to belows procedure.

### Voltage Output Check

- The following steps verify basic output voltage functions with no load.
  1. Turn on the power supply.
  2. The output is disabled (the OUTPUT OFF is displayed on the LCD)
  3. in order to measure the voltage, connect the DVM to output terminals properly.
  4. Press the "OUTP ON/OFF" key in order to output the voltage.
  5. Press the "V/I LMT " key and move the under bar cursor to voltage value.
  6. Press the left cursor move key and select the voltage resolution what you want.
  7. in order to increase or decrease, turn the encoder switch CW or CCW.
  8. Compare between LCD display real voltage value and DVM annunciator.

### Current Output Check

- The following steps check basic current functions with a short across the power supply's ou
  1. Turn on the power supply.
  2. The output is disabled (the OUTPUT OFF is displayed on the LCD)
  3. Press the "OUTP ON/OFF" key in order to output the voltage.
  4. Press the "V/I LMT " key and move the under bar cursor to current value.
  5. Press the left cursor move key and select the voltage resolution what you want.
  6. in order to increase the voltage to 5V, turn the encoder switch CW or CCW.
  7. Press the right cursor move key and select the current resolution what you want.
  8. in order to increase or decrease, turn the encoder switch CW or CCW.
  9. in order to change to "OUTPUT OFF" mode, press the "Output On/Off" Key.
  10. in order to measure the current, connect the DAM to output terminals properly.
  11. Press the "V/I LMT " key and move the under bar cursor to voltage value.
  12. Compare between LCD display real current value and DAM annunciator.

### 3. Front-Panel Operating

If entering to each function of power supply, it returns or cancels to local mode when you press the IO/Local, Protection, Store, Recall key or leave the power supply without any events after 5 seconds later. The select and confirm key is it's own key. For examples, if you want to store current state, at first press the "store" key and set the number what number you will store. After selected store number, press the "store" key in order to finish the store. You can see the display Done in the LCD display.

#### Overview





1. **Constant Voltage Operating(CV)**  
Explain about the operating constant voltage output mode.
2. **Constant Current Operating(CC)**  
Explain about the operating constant current output mode.
3. **Remote Voltage Sensing**  
Explain about the voltage sensing of DUT.
4. **Programming Over Voltage Protection(OVP)**  
Explain about the programming of over voltage protection.
5. **Programming Over Current Protection(OCP)**  
Explain about the programming of over current protection.
6. **Programming Under Voltage Limit(UVL)**  
Explain about the programming of under voltage limit.
7. **Programming Over Voltage Limit(OVL)**  
Explain about the programming of over voltage limit.
8. **Programming Under Current Limit(UCL)**  
Explain about the programming of under current limit.
9. **Programming Over Current Limit(OCL)**  
Explain about the programming of over current limit.
10. **Key Lock**  
Explain about the locking and clearing of front panel operating.
11. **IO/Local**  
Explain about remote Interface setting/local mode changing and error message display.
12. **Limit Display**  
Explain the confirm of voltage/current setting or real output value.
13. **Store**  
Explain the method of storing the power supply state in the 『user memory』 chip.
14. **Recall**  
Explain the method of recalling the power supply state from the 『user memory』 chip.
15. **Output ON/OFF**  
Explain the power output on and off.
16. **Error Message Display**  
Explain the confirm the error of power supply.

#### *Note 1*

It is possible to set the remote interface method by pressing "I/O Local" key on the front-panel.

### 3-1. Constant Voltage Operating(CV)

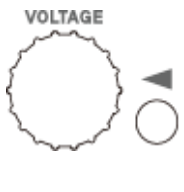
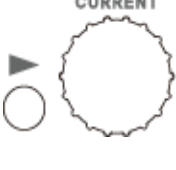
To set up the power supply for constant voltage (CV) operation, proceed as follows.  
(This operating is the examples that the function of "Last State Mode" is disable.)

	<ul style="list-style-type: none"> <li>Turn on the power supply After turned on, check the power supply displays "**OUTPUT OFF**" Mode.</li> <li>Connect the DUT to output terminals.</li> </ul>
	<ul style="list-style-type: none"> <li>in order to set the limit value, press the LMT Key.</li> </ul>
	<ul style="list-style-type: none"> <li>Press the left key and move the under bar cursor to voltage value. in order to increase or decrease the voltage value, turn the encoder switch CW or CCW. Under the protection(OVP/UVL/OVL) setting state, voltage cannot be over [H], protection level. If the voltage value is over the protection setting value, instrument "displays "PROTECTION LIMIT" message and voltage will set to protection level value.</li> </ul>
	<ul style="list-style-type: none"> <li>If you set the current value higher than DUT consumes real value, you can prevent to damage the DUT. Refer to below procedure of current setting.</li> </ul>
	<ul style="list-style-type: none"> <li>in order to set the current value, use the right cursor key and encoder knob. Under the protection(OVP/UVL/OVL) setting state, current cannot be over [H], protection level. If the voltage value is over the protection setting value, instrument "displays "PROTECTION LIMIT" message and current will set to protection level value.</li> </ul>
	<ul style="list-style-type: none"> <li>If the all setting is finished, enable the output.(Press the output ON/OFF key) and then power supply changes to readback display from limit display.</li> </ul>
	<ul style="list-style-type: none"> <li>CV lamp is on, CC lamp is off. If lamp is reversed, check the current setting value is low. If the current value is low, increase the current value limit.</li> </ul>

» Related Remote Interface Command

*APPLY{<voltage>,<current>}*

*VOLT{<voltage>|UP|DOWN}*

*CURR{<current>|UP|DOWN}*

*OUTP{OFF|ON}*

*Apply 1* *OUTP OFF* *disable the output*  
*VOLT 10* *set the voltage to 10V*  
*CURR 5* *set the current to 5A*  
*OUTP ON* *enable the output*

*Apply 2* *OUTP OFF* *disable the output*  
*APPLY 10,5* *set 10V /5A*  
*OUTP ON* *enable the output*







#### Note

- Left cursor key is for voltage under bar left moving, right cursor key is for current under bar right moving.
- About readback display? Display state that is the voltage and current,s output.

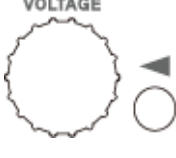

## 3-2. Constant Current Operating(CC)

To set up the power supply for constant current (CC) operation, proceed as follows.

	<ul style="list-style-type: none"> <li>Turn on the power supply After turned on, check the power supply displays "**OUTPUT OFF**" Mode.</li> <li>Connect the DUT to output terminals.</li> </ul>
	<ul style="list-style-type: none"> <li>in order to set the limit value, press the LMT Key.</li> </ul>
	<ul style="list-style-type: none"> <li>Press the left key and move the under bar cursor to voltage value. in order to increase or decrease the voltage value, turn the encoder switch CW or CCW. <i>Under the protection(OVP/UVL/OVL) setting state, voltage cannot be over protection level. If the voltage value is over the protection setting value, instrument "displays "PROTECTION LIMIT" message and voltage will set to protection level value.</i></li> </ul>
	<ul style="list-style-type: none"> <li>in order to set the current value, use the right cursor key and encoder knob. <i>Under the protection(OVP/UVL/OVL) setting state, current cannot be over protection level. If the voltage value is over the protection setting value, instrument "displays "PROTECTION LIMIT" message and current will set to protection level value.</i></li> </ul>
	<ul style="list-style-type: none"> <li>If the all setting is finished, enable the output.(Press the output ON/OFF key) and then power supply changes to readback display from limit display.</li> </ul>
	<ul style="list-style-type: none"> <li>CC lamp is on, CV lamp is off. If lamp is reversed, check the voltage setting value is low. If the voltage value is low, increase the current value limit.</li> </ul>

» Related Remote Interface Command

*APPLY{<voltage>,<current>}*

*VOLT{<voltage>|UP|DOWN}*

*CURR{<current>|UP|DOWN}*

*OUTP{OFF|ON}*

*Apply 1 OUTP OFF    disable the output*

*VOLT 10        set the voltage to 10V*

*CURR 5        set the current to 5A*

*OUTP ON        enable the output*

*Apply 2 OUTP OFF    disable the output*

*APPLY 10,5    set 10V /5A*

*OUTP ON        enable the output*

### 3–3. Remote Voltage Sensing

Remote voltage sensing is used to maintain regulation at the load and reduce the degradation of regulation that would occur due to the voltage drop in the leads between the power supply and the load. By connecting the power supply for remote voltage sensing, voltage is sensed at the load rather than at the power supply's output terminals. This will allow the power supply to automatically compensate for the voltage drop in applications with long lead lengths as well as to accurately read back the voltage directly across the load. When the power supply is connected for remote sensing, the OVP circuit senses the voltage at the sensing points (load) and not the output terminals.

#### CV Regulation

The voltage load regulation specification in chapter 8 applies at the output terminals of the power supply. When remote sensing, add 5 mV to this specification for each 1 V drop between the positive sensing point and (+) output terminal due to the change in load current. Because the sense leads are part of the power supply's feedback path, keep the resistance of the sense leads at or below 0.5 per lead to maintain the above specified performance.

#### Output Rating

The rated output voltage and current specifications apply at the output terminals of the power supply that you purchased product's capacity. With remote sensing, any voltage dropped in the load leads must be added to the load voltage to calculate maximum output voltage. The performance specifications are not guaranteed when the maximum output voltage is exceeded. If the excessive demand on the power supply forces the power supply to lose regulation. Also voltage remote sensing value is exceeded 1V per one wire, the power supply can be under unregulated state regardless of maximum output voltage.

#### *Note*

Unregulated state? If the power supply should go into a mode of operation that is neither CV or CC, the power supply is unregulated. In this mode the output is not predictable. The unregulated condition may be the result of the ac line voltage below the specifications. The unregulated condition may occur momentarily. For example when the output is programmed for a large voltage step; the output capacitor or a large capacitive load will charge up at the current limit setting. During the ramp up of the output voltage the power supply will be in the unregulated mode. During the transition from CV to CC as when the output is shorted, the unregulated state may occur briefly during the tra

#### Output Noise

Any noise picked up on the sense leads also appears at the output of the power supply and may adversely affect the voltage load regulation. Refer to <Figure. 3–1>.

- Twist the sense leads to minimize external noise pickup.
- Run the sense leads parallel and close to the load leads.
- In noisy environments it may be necessary to shield the sense leads.
- Ground the shield at the power supply end only.
- About load leads and sense leads, connect in the nearest distance.

## Stability

Using remote sensing under certain combinations of load lead lengths and large load capacitances may cause your application to form a filter, which becomes part of the voltage feedback loop. The extra phase shift created by this filter can degrade the power supply's stability, resulting in poor transient response or loop instability. In severe cases, it may cause oscillations.

To minimize this possibility, refer to below method.

- Keep the load leads and sense leads as short as possible.
- Twist the load leads and sense leads together..
- Connect sense leads safely to the DUT.

As the sense leads are part of the power supply's programming feedback loop, accidental open-connections of sense or load leads during remote sensing operation have various unwanted effects.

- Reminder never connect the load leads to sense lead terminal.

## Connecting Remote Voltage Sensing

Remote voltage sensing requires connecting the load leads from output terminals to the load and connecting the sense leads from sense terminals to the load as shown below. Observe polarity when connecting the sensing leads to the load. Never connect the load leads to sense lead terminal. If you connect, the power supply can be under unregulated state.

### Note

Notice that the copper shorting wires should be removed from the output and sense terminals for remote voltage sensing connections.



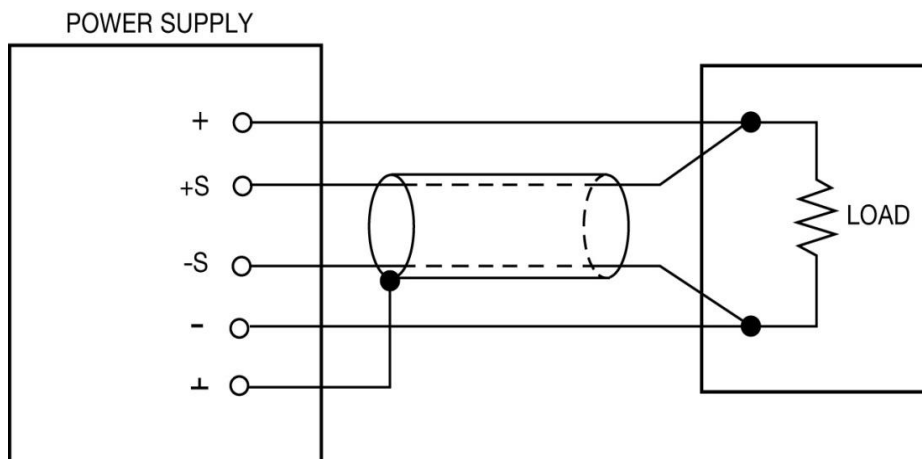



For local voltage sensing connections, the sense leads must be connected to the output termi



< Figure. 3-1 >

### 3-4. Programming Over Voltage Protection(OVP)

Overvoltage protection guards the load against output voltages that reach a specified value greater than the programmed protection level. Below procedure is for setting the OVP level.  
*disable the OVP at the Factory Mode.*

	<p>Turn on the power supply          After turned on, check the power supply displays "**OUTPUT OFF**" Mode.</p>
	<p>Press the "Protection" key in order to enter the OVP menu.          LCD Display <span style="border: 1px solid black; padding: 2px;">PROTECT&gt; 1.OVP</span></p>
	<p>Press the "Protection" key one more time at the "1.OVP" state.          LCD Display <span style="border: 1px solid black; padding: 2px;">OVP SET&gt; 32.00V</span></p>
	<p>Move the under bar cursor location where you want to change.</p>
	<p>Set the trip level.  <i>Note that you cannot set the trip levels to lower than current real output volt in order to prevent the operator's malfunction occurring.</i></p>
	<p>After set the trip levels that you want, press the "Protection" Key.          LCD Display <span style="border: 1px solid black; padding: 2px;">CHANGED</span>          After displayed above message, The power supply will exit the OVP menu and the display will return to the meter mode.</p>
<p>Cancelling          Wait 5 sec</p>	<p>If you don't want to change the OVP levels, just wait during 5 seconds.          LCD Display <span style="border: 1px solid black; padding: 2px;">CANCEL...</span></p>

» Related Remote Interface Command

VOLT:OVP {<voltage>}

VOLT:OVP?

VOLT:TRIP?

VOLT:CLE

Refer : VOLT:OVP 25

VOLT:OVP?

VOLT:OVP:TRIP?

VOLT:OVP:CLE

Set OVP Level

Confirm OVP Level

Confirm the Otripped OVP

OVP Trip Clear

**Note**

About initial OVP setting, refer to Default Setting Values of "1-6. Check After Power On"

If the real output voltage is higher than OVP level value, "OVP TRIPPED" message appears on the display. And output voltage and current is dropped to near zero. In order to output the voltage and current, at first remove the DUT from load wire and clear the tripped OVP as like below method. The reason of tripped OVP occurring,

First, OVP setting level is lower than rear output voltage level. Therefore, increase the OVP level.



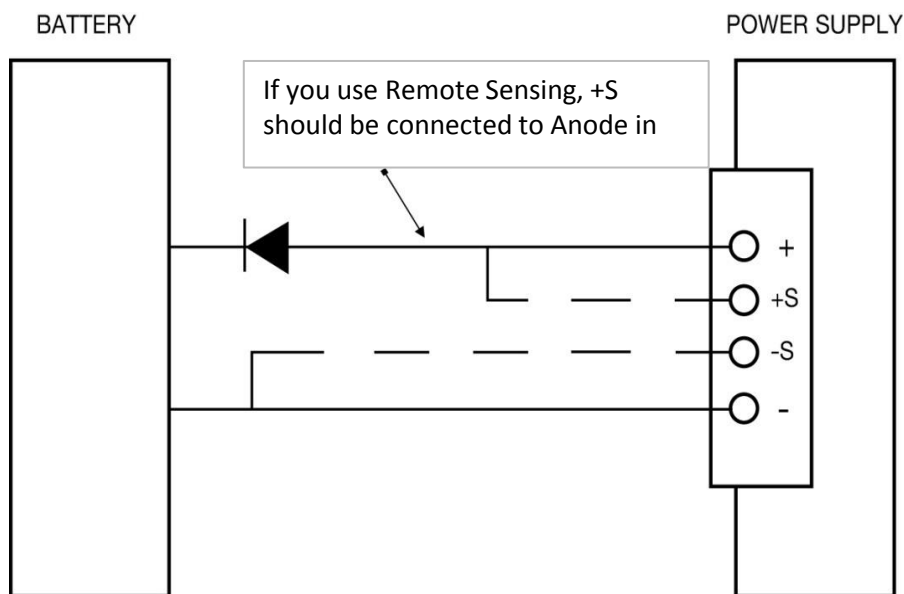

Second, Maybe the DUT is like a coil, motor and as like a source that make an in rush curren. To avoid this, a UF-diode must be connected in series with the output as shown below.

Third, In case of using the DUT as like source. If external voltage source such as a battery is connected across the output, feedback voltage level is higher than OVP level and it occurs tripped OVP. A diode must be connected in series with the output as shown below



< Figure. 3-2 >

Forth, If you can't control the tripped OVP, turn off the OVP function. Enter the "Factory mode" and move to "5.OVP USE" and then disable this function.

	<ul style="list-style-type: none"> <li>When occurs OVP trip01, "OVP TRIPPED" message appears on the display</li> </ul>
	<ul style="list-style-type: none"> <li>In order to clear tripped OVP, increase the OVP Level.</li> <li>In order to increase OVP level, press the "Protection" key.</li> </ul> <p>LCD Display <input type="text" value="protect&gt; 1.ovp"/></p>
	<ul style="list-style-type: none"> <li>"protect&gt; 1.ovp " press the "Protection" key one more time.</li> </ul> <p>LCD Display <input type="text" value="ovp set&gt; 15.00v"/></p>
	<ul style="list-style-type: none"> <li>Move the under bar cursor where you want to change the level.</li> </ul>
	<ul style="list-style-type: none"> <li>Readjust the OVP level by using the encoder knob.</li> </ul>
	<ul style="list-style-type: none"> <li>Finished to change the level, press the "Protection" key.</li> </ul> <p>LCD Display <input type="text" value="CHANGED"/></p> <p>After displayed above message, return to before state that tripped OVP.</p>

» Related Remote Interface Command

*VOLT:OVP {<voltage>}*

*VOLT:OVP?*

*VOLT:OVP:TRIP?*

*VOLT:OVP:CLE*

*Apply 1: Method of checking tripped OVP or not and readjust the OVP level.*

*VOLT:OVP:TRIP? Return value "1" Check the tripp OVP state*

*VOLT:OVP 32 Set the OVP level.*

*VOLT:OVP:CLE Clear the OVP trip.*

*Apply 2: Method of checking tripped OVP or not and decrease the OVP level.*

*VOLT:OVP:TRIP? Return value "1" Check the tripp OVP state*







*VOLT 0 Set the voltage value to zero.*

*VOLT:OVP:CLE Clear the OVP trip.*

### 3-5. Programming Over Current Protection(OCP)

Overcurrent protection guards the load against output currents that reach a specified value greater than the programmed protection level. Below procedure is for setting the OCP level.

*disable the OCP at the Factory Mode.*

	<p>Turn on the power supply After turned on, check the power supply displays "**OUTPUT OFF**" Mode.</p>
<p>Protection</p>  <p>Error</p>	<p>Press the "Protection" key. LCD Display <span style="border: 1px solid black; padding: 2px;">PROTECT&gt; 1.OVP</span></p>
	<p>Press the right cursor key in order to enter the OCP. LCD Display <span style="border: 1px solid black; padding: 2px;">PROTECT&gt; 2.OCP</span></p>
<p>Protection</p>  <p>Error</p>	<p>Press the "Protection" key one more time at the "2. ocp" state. LCD Display <span style="border: 1px solid black; padding: 2px;">OcP SET&gt; 88.00a</span></p>
	<p>Move the under bar cursor location where you want to change.</p>
	<p>Set the trip level. Note that you cannot set the trip levels to lower than current real output current in order to prevent the operator's malfunction occurring.</p>
<p>Protection</p>  <p>Error</p>	<p>After set the trip levels that you want, press the "Protection" Key. LCD Display <span style="border: 1px solid black; padding: 2px;">CHANGED</span> After displayed above message, The power supply will exit the OVP menu and the display will return to the meter mode.</p>
<p>Cancelling</p> <p>Wait 5 sec</p>	<p>If you don't want to change the OVP levels, just wait during 5 seconds. LCD Display <span style="border: 1px solid black; padding: 2px;">CANCEL...</span></p>

» Related Remote Interface Command

*CURR:OCP {<current>}*

*CURR:OCP?*

*CURR:OCP:TRIP?*

*CURR:OCP:CLE*

*Apply: CURR:OCP 50*

*Set the OCP level.*

#### Note

About initial OCP setting, refer to Default Setting Values of "1-6. Check After Power On"

If the real output current is higher than OCP level value, "OCP TRIPPED" message appears on the display. And output voltage and current is dropped to near zero. in order to output the voltage and current, at first remove the DUT from load wire and clear the tripped OCP as like below method. The reason of tripped OCP occurring,







First, OCP setting level is lower than rear output current level. Therefore, increase the OCP level.

Second, Maybe the DUT is like a coil, motor and as like a source that make an in rush curren. To avoid this, a UF-diode must be connected in series with the output as shown below.

Third, In case of using the DUT as like source. If external voltage source such as a battery is connected across the output, feedback current level is higher than OCP level and it occurs tripped OCP. A diode must be connected in series with the output as shown below.

Forth, If you can't control the tripped OCP, turn off the OCP function.

Enter the "Factory mode" and move to "6.OCP USE" and then disable this function.

	<ul style="list-style-type: none"> <li>When occurs OCP trip0 , "OCP TRIPPED" message appears on the display</li> </ul>
	<ul style="list-style-type: none"> <li>in order to clear tripped OCP, increase the OCP Level.</li> <li>in order to increase OCP level, press the "Protection" key.</li> </ul> LCD Display <span style="border: 1px solid black; padding: 2px;">Protect&gt; 1.ovp</span>
	<ul style="list-style-type: none"> <li>Press the right cursor key in order to enter the OCP.</li> </ul> LCD Display <span style="border: 1px solid black; padding: 2px;">PROTECT&gt; 2.OCP</span>
	<ul style="list-style-type: none"> <li>In the "protect&gt; 2.ocp ", press the "Protection" key one more time.</li> </ul> LCD Display <span style="border: 1px solid black; padding: 2px;">OcP SET&gt; 50.00a</span>
	<ul style="list-style-type: none"> <li>Move the under bar cursor where you want to change the level.</li> </ul>
	<ul style="list-style-type: none"> <li>Readjust the OCP level by using the encoder knob.</li> </ul>
	<ul style="list-style-type: none"> <li>Finished to change the level, press the "Protection" key.</li> </ul> LCD Display <span style="border: 1px solid black; padding: 2px;">CHANGED</span> After displayed above message, return to before state that tripped OCP.

» Related Remote Interface Command

*CURR:OCP {<current>}*

*CURR:OCP?*

*CURR:OCP:TRIP?*

*CURR:OCP:CLE*

*Apply 1 : Method of checking tripped OCP or not and readjust the OCP level.*

*CURR:OCP:TRIP? Return value "1" Check the tripped OCP.*

*CURR:OCP 80*

*Set the OCP level*

*CURR:OCP:CLE*

*clear the OCP trip.*

*Apply 2 Method of checking tripped OCP or not and lower the current level.*

*CURR:OCP:TRIP? Return value "1" Check the tripped OCP.*

*CURR 0*

*Set current 0*









*CURR:OCP:CLE*

*clear the OCP trip.*

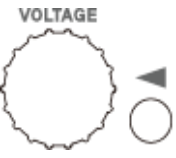

### 3-6. Programming Under Voltage Limit(UVL)

Normally, you can adjust the voltage from 0V to maximum voltage but if you set the UVL level, you can adjust the voltage from UVL level to maximum voltage.

	<p>Turn on the power supply After turned on, check the power supply displays "**OUTPUT OFF**" Mode.</p>
	<p>Before setting the UVL level, voltage limit setting value must be higher than UVL level. And then you can set the UVL limit value.</p>
	<p>in order to set the voltage, move the under bar cursor where you want by using left cursor key and set the voltage by using encoder knob. <i>Under the protection(OVP/UVL/OVL) setting state, voltage cannot be over the protection level. If the level over, " PROTECTION LIMIT" message appears on the display and voltage value returns to protection level value.</i></p>
	<p>Press the "Protection" key in order to set the UVL level. LCD Display <span style="border: 1px solid black; padding: 2px;">PROTECT&gt; 1.OVP</span></p>
	<p>Move to the UVL menu by using right cursor key. LCD Display <span style="border: 1px solid black; padding: 2px;">PROTECT&gt; 3.uvl</span></p>
	<p>"protect&gt; 3.UVL" 상태에서 Protection Key를 한번 더 누르세요 LCD Display <span style="border: 1px solid black; padding: 2px;">UVL SET&gt; 00.00v</span></p>
	<p>Move the under bar cursor location where you want to change.</p>
	<p>Set the Under Voltage Level by using encoder knob. Note that you cannot set the limit levels to lower than current real output voltage in order to prevent the operator's malfunction occurring.</p>
	<p>After set the limit levels that you want, press the "Protection" Key. LCD Display <span style="border: 1px solid black; padding: 2px;">CHANGED</span> After displayed above message, The power supply will exit the UVL menu and the display will return to the meter mode.</p>
<p>Cancelling Wait 5 sec</p>	<p>If you don't want to change the UVL levels, just wait during 5 seconds. LCD Display <span style="border: 1px solid black; padding: 2px;">CANCEL...</span></p>

» Related Remote Interface Command

VOLT:UVL {<voltage>}

VOLT:UVL ?

Apply : VOLT:UVL 5









Set the UVL level

#### Note

About initial UVL setting, refer to Default Setting Values of "1-6. Check After Power On"

### 3-7. Programming Over Voltage Limit(OVL)

Normally, you can adjust the voltage from 0V to maximum voltage but if you set the OVL level, you can adjust the voltage from 0V to OVL level.

	<p>Turn on the power supply After turned on, check the power supply displays "***OUTPUT OFF**" Mode.</p>
	<p>Before setting the OVL level, voltage limit setting value must be lower than OVL level. And then you can set the OVL limit value.</p>
	<p>in order to set the voltage, move the under bar cursor where you want by using left cursor key and set the voltage by using encoder knob. <i>Under the protection(OVP/UVL/OVL) setting state, voltage cannot be over the protection level. If the level over, " PROTECTION LIMIT" message appears on the display and voltage value returns to protection level value.</i></p>
	<p>Press the "Protection" key in order to set the OVL level. LCD Display <span style="border: 1px solid black; padding: 2px;">PROTECT&gt; 1.OVP</span></p>
	<p>Move to the OVL menu by using right cursor key. LCD Display <span style="border: 1px solid black; padding: 2px;">PROTECT&gt; 4.Ovl</span></p>
	<p>Press the "Protection" key one more time at the "4. ovl" state. LCD Display <span style="border: 1px solid black; padding: 2px;">OVL SET&gt; 31.50v</span></p>
	<p>Move the under bar cursor location where you want to change.</p>
	<p>Set the Over Voltage Level by using encoder knob. Note that you cannot set the limit levels to higher than current real output voltage in order to prevent the operator's malfunction occurring.</p>
	<p>After set the limit levels that you want, press the "Protection" Key. LCD Display <span style="border: 1px solid black; padding: 2px;">CHANGED</span> After displayed above message, The power supply will exit the OVL menu and the display will return to the meter mode.</p>
<p>Cancelling Wait 5 sec</p>	<p>If you don't want to change the OVL levels, just wait during 5 seconds. LCD Display <span style="border: 1px solid black; padding: 2px;">CANCEL...</span></p>

» Related Remote Interface Command

VOLT:OVL {<voltage>}

VOLT:OVL?

Apply : VOLT:OVL 20









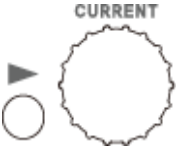

OVL Level Setting

#### Note

About initial OVL setting, refer to Default Setting Values of "1-6. Check After Power On"

### 3-8. Programming Under Current Limit(UCL)

Normally, you can adjust the current from 0V to maximum current but if you set the UCL level, you can adjust the current from UCL level to maximum current.

	<p>Turn on the power supply After turned on, check the power supply displays "***OUTPUT OFF**" Mode.</p>
<p>Limit</p> 	<p>Before setting the UCL level, current limit setting value must be higher than UCL level. And then you can set the UCL limit value.</p>
<p>CURRENT</p> 	<p>in order to set the current, move the under bar cursor where you want by using right cursor key and set the current by using encoder knob. <i>Under the protection(OVP/UVL/OVL) setting state, current cannot be over the protection level. If the level over, " PROTECTION LIMIT " message appears on the display and current value returns to protection level value.</i></p>
<p>Protection</p>  <p>Error</p>	<p>Press the "Protection" key in order to set the UCL level. LCD Display <span style="border: 1px solid black; padding: 2px;">PROTECT&gt; 1.OVP</span></p>
 	<p>Move to the CVL menu by using right cursor key. LCD Display <span style="border: 1px solid black; padding: 2px;">PROTECT&gt; 5.uCl</span></p>
<p>Protection</p>  <p>Error</p>	<p>Press the "Protection" key one more time at the "5. ucl" state. LCD Display <span style="border: 1px solid black; padding: 2px;">UCL SET&gt; 00.00A</span></p>
	<p>Move the under bar cursor location where you want to change.</p>
	<p>Set the Under Current Level by using encoder knob. Note that you cannot set the limit levels to lower than current real output current in order to prevent the operator's malfunction occurring.</p>
<p>Protection</p>  <p>Error</p>	<p>After set the limit levels that you want, press the "Protection" Key. LCD Display <span style="border: 1px solid black; padding: 2px;">CHANGED</span> After displayed above message, The power supply will exit the UCL menu and the display will return to the meter mode.</p>
<p>Cancelling</p> <p>Wait 5 sec</p>	<p>If you don't want to change the UCL levels, just wait during 5 seconds. LCD Display <span style="border: 1px solid black; padding: 2px;">CANCEL...</span></p>

» Related Remote Interface Command

*CURR:UCL {<current>}*

*CURR:UCL?*

*Apply: CURR:UCL 5*









*Set the UCL level.*

#### Note

About initial OCL setting, refer to Default Setting Values of "1-6. Check After Power On"

### 3-9. Programming Over Current Limit(OCL)

Normally, you can adjust the current from 0V to maximum voltage but if you set the OCL level, you can adjust the current from 0A to OCL level.

	<p>Turn on the power supply After turned on, check the power supply displays "***OUTPUT OFF**" Mode.</p>
	<p>Before setting the OCL level, current limit setting value must be lower than OCL level. And then you can set the OCL limit value.</p>
	<p>in order to set the current, move the under bar cursor where you want by using right cursor key and set the current by using encoder knob. <i>Under the protection(OVP/UVL/OVL) setting state, current cannot be over the protection level. If the level over, " PROTECTION LIMIT" message appears on the display and current value returns to protection level value.</i></p>
	<p>Press the "Protection" key in order to set the OCL level. LCD Display <span style="border: 1px solid black; padding: 2px;">PROTECT&gt; 1.OVP</span></p>
	<p>Move to the OCL menu by using right cursor key. LCD Display <span style="border: 1px solid black; padding: 2px;">PROTECT&gt; 6.Ocl</span></p>
	<p>Press the "Protection" key one more time at the "6. OCL" state. LCD Display <span style="border: 1px solid black; padding: 2px;">OCL SET&gt; 88.00A</span></p>
	<p>Move the under bar cursor location where you want to change.</p>
	<p>Set the Over Current Level by using encoder knob. Note that you cannot set the limit levels to lower than current real output current in order to prevent the operator's malfunction occurring.</p>
	<p>After set the limit levels that you want, press the "Protection" Key. LCD Display <span style="border: 1px solid black; padding: 2px;">CHANGED</span> After displayed above message, The power supply will exit the OCL menu and the display will return to the meter mode.</p>
<p>Cancelling Wait 5 sec</p>	<p>If you don't want to change the OCL levels, just wait during 5 seconds. LCD Display <span style="border: 1px solid black; padding: 2px;">CANCEL...</span></p>

» Related Remote Interface Command

*CURR:OCL {<current>}*  
*CURR:OCL?*

*Apply : CURR:OCL 44*

*Set the OCL level.*



#### Note

About initial OCL setting, refer to Default Setting Values of "1-6. Check After Power On"

### 3-10. Key Lock

Locking or unlocking of front panel's operating state.

The locking function can be used to disable the knob, thereby preventing any unwanted changes during an experiment, or when you leave the power supply unattended.

	<ul style="list-style-type: none"> <li>Turn on the power supply After turned on, check the power supply displays "**OUTPUT OFF**" Mode.</li> </ul>
<p>Protection</p>  <p>Error</p>	<ul style="list-style-type: none"> <li>in order to lock the front panel operating, press the "Protection/Key Lock" key during 3 seconds over. LOCK annunciator is on and locking.</li> </ul>
<p>Protection</p>  <p>Error</p>	<ul style="list-style-type: none"> <li>in order to unlock the front panel operating, press the "Protection/Key Lock" key during 3 seconds over. LOCK annunciator is off and unlocking.</li> </ul>

» Related Remote Interface Command

`KEYL {OFF/ON}`

`KEYL?`

*Apply : Check the "KEY LOCK" and then when the return value is unlock state, command is following*

*KEYL? Return value "0" Check the lock state(value "0" means unlocking state)*

*KEYL ON*

*Set the lock*

#### Note1

*In the "Factory Mode", if enable "Auto Key Lock ", the instrument lock the front panel automatically after 1 minute from last use of the instrumet.*

#### Note2

*Lock function enable under the remote interface state without using the key lock function. Key Lock.*

### 3-11. IO/Local

To configure the power supply for the RS-232, RS485, USB and TCP/IP interface. RS232C, RS485 and USB interface is standard, in case of TCP/IP, it is optional. When the power supply is shipped, I/O interface is set the RS232C protocol and baud rate is 9600bps.

*Communication setting is able to be set by front panel key.*

- The I/O and local setting are stored in non-volatile memory, and does not change when power has been off or after a remote interface reset.
- If remote interface works, the lamp of RMT on front panel lits and power supply is remotely controlled preferentially.
- If you want to control power supply on local mode, at first finish remote interface and then press the "I/O & LOCAL" key. Lamp of "RMT" turn off and you can control.







*Although the RMT lamp is off but you can not control the instrument, maybe it is under KEY LOCK.*

*Press the "Protection" key and unlock.*

- Press the IO/Local Key for 3 seconds than Remote Mode is on.

#### RS232C Setting

RS232C setting procedure.

	<ul style="list-style-type: none"> <li>■ Turn on the power supply After turned on, check the power supply displays "**OUTPUT OFF**" Mode.</li> </ul>
	<ul style="list-style-type: none"> <li>■ Press "I/O" key in order to set RS232C interface. LCD Display <span style="border: 1px solid black; padding: 2px;">I/O&gt; 1.RS232C</span> <i>Or it is differ following before state</i></li> </ul>
	<ul style="list-style-type: none"> <li>■ Following before state, appears RS232C, RS485, USB and TCP/IP on the display. If the display is not "1.RS232C" press the cursor key until changing to "I/O&gt; 1.RS232C" on the display 되도록 합니다. LCD Display <span style="border: 1px solid black; padding: 2px;">I/O&gt; 1.RS232C</span></li> </ul>
	<ul style="list-style-type: none"> <li>■ Press "I/O" key in order to set baud rate. LCD Display <span style="border: 1px solid black; padding: 2px;">&gt;br 1: 9600 bps</span> <i>Or it is differ following before state</i></li> </ul>
	<ul style="list-style-type: none"> <li>■ Baud rate is consist of 9600, 19200, 38400, 57600, 115200 and 230400bps. You must match between remote interface device's baud rate. For examples, in order to select 115200bps, press right cursor key four times. LCD Display <span style="border: 1px solid black; padding: 2px;">&gt;br 5: 115200 bps</span></li> </ul>
	<ul style="list-style-type: none"> <li>■ in order to finish the I/O setting, press the "I/O" key. LCD Display <span style="border: 1px solid black; padding: 2px;">SAVED</span> Through above procedure, interface method is RS232C and baud rate is 115200</li> </ul>

#### Note

bps? The initial of Bit per Second, data transmission unit of 1bit per one second.

## RS232C Configuration

- RS232C & RS485 are fixed as following.  
 Data Bit :  
 Stop Bit :  
 Parity Bit : None

- RS232C Data frame.



- in order to connect the power supply of RS485 type, it is necessary standard cross cable of female type. Below is connection drawing of female type cross cable. proceed as follows.

*"Refer to chapter 1-2. Accessories & Option" and then you can choose the communication cable length or other using method.*

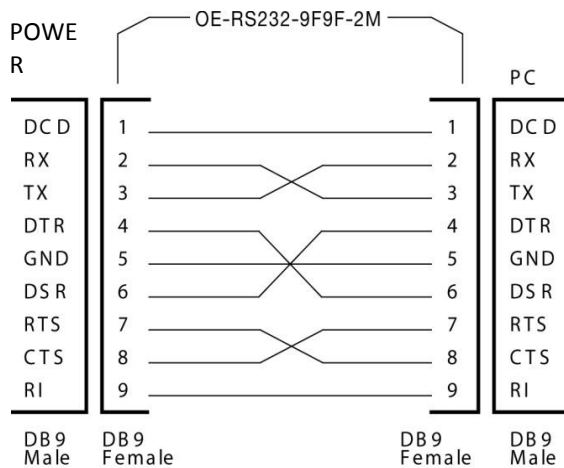

< Figure. 3-3 >

- If you want to connect the power supply with PC by using another cable(for examples, PIN), please use another adapter



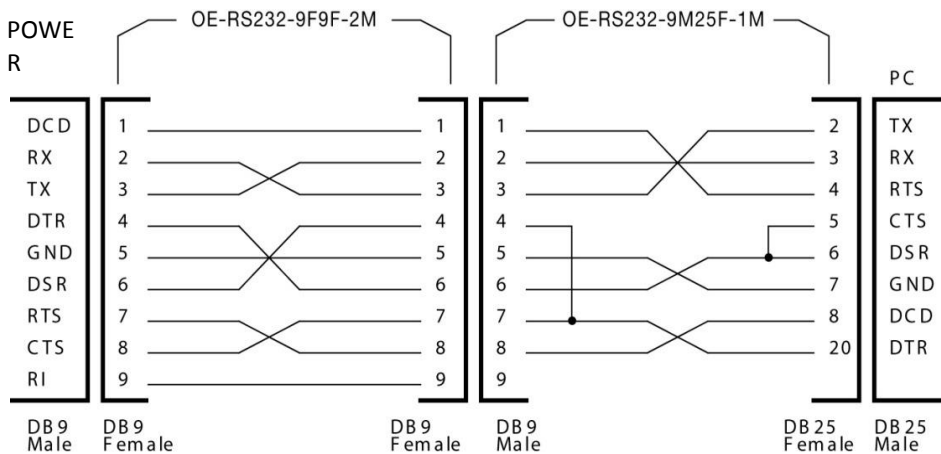



*Refer to chapter 1-2. Accessories & Option*



< Figure. 3-4 >

## RS485 Setting

It is possible to control up to 255 devices include remote device after connected each devices by parallel interface method. RS485 setting procedure.

	<p>Turn on the power supply After turned on, check the power supply displays <b>"**OUTPUT OFF**"</b> Mode.</p>
	<p>Press "I/O" key in order to set RS485 interface. LCD Display <span style="border: 1px solid black; padding: 2px;">I/O&gt; 1.RS232C</span> <i>Or it is differ following before state.</i></p>
	<p>Following before state, appears RS232C, RS485, USB and TCP/IP on the display. If the display is not "2.RS485" press the cursor key until changing to "I/O&gt; 1.RS485" on the display LCD Display <span style="border: 1px solid black; padding: 2px;">I/O&gt; 2.RS485</span></p>
	<p>Press "I/O" key in order to set baud rate. LCD Display <span style="border: 1px solid black; padding: 2px;">&gt;br 1: 9600 bps</span> <i>Or it is differ following before state</i></p>
	<p>Baud rate is consist of 9600, 19200, 38400, 57600, 115200 and 230400bps. You must match between remote interface device's baud rate. Press "I/O" key after finished to select. LCD Display <span style="border: 1px solid black; padding: 2px;">&gt;address no. 05</span></p>
	<p>Choose the address number by using encoder knob. In case of using the 2 or more devices and connecting parallel interface, you must select a unique address for the power supply.</p>
	<p>in order to finish the I/O setting, press the "I/O" key. LCD Display <span style="border: 1px solid black; padding: 2px;">SAVED</span> Through above procedure, interface method is RS485.</p>

### Note

If you order us our converter module that convert from RS485 to RS232C, we can attach it in the power supply. I.e, even if you use the converter kind of external type, you don't need the DC source that you supply 5V DC source for operating converter.



## RS485 Connection Drawing

■ RS485 connector consists of 4pin one touch terminal and below figure.3-5 is rear side view.

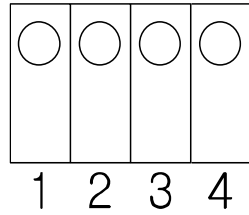

Pin Description	
No	Description
1	DC +5V/0.2A Output
2	Data +
3	Data -
4	GND(Earth Ground)

< Figure. 3-5 >

## RS485 Configuration

■ In order to connect between RS485 line and remote device as like PC or PLC, you need extra wire that below figure connection. Refer to Figure. 3-6.

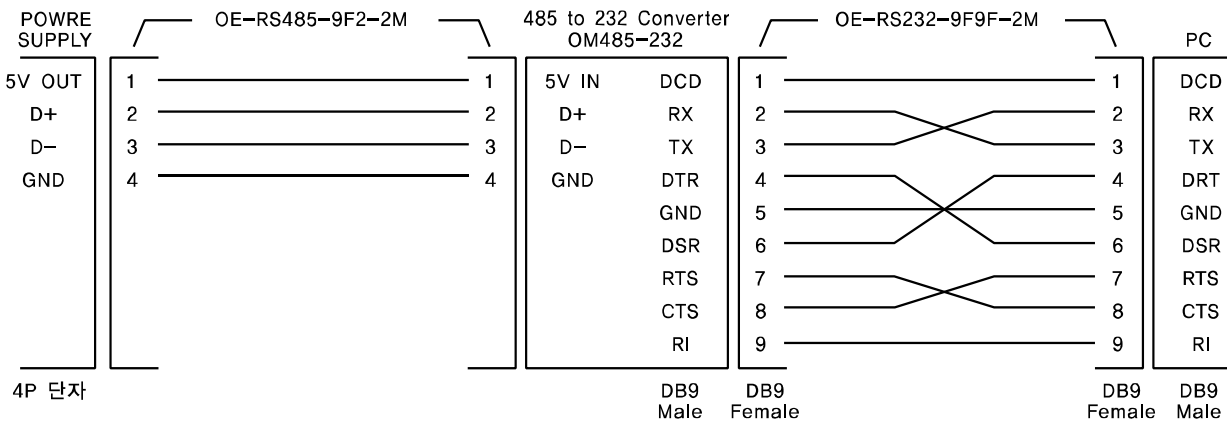

485 to 232 Converter

< Figure. 3-6 >

■ RS485 PC Interface setting.

RS485 module outputs DC 5V/0.3A from RS485 cable pin in case of OPE-Series4, so you don't need another power supply to supply the 485-232C communication operating. The length of between power supply and OM485-232(RS485 to RS232 Converter) must be short in order to avoid voltage loss.

### RS232C RS 485/485 Configuration

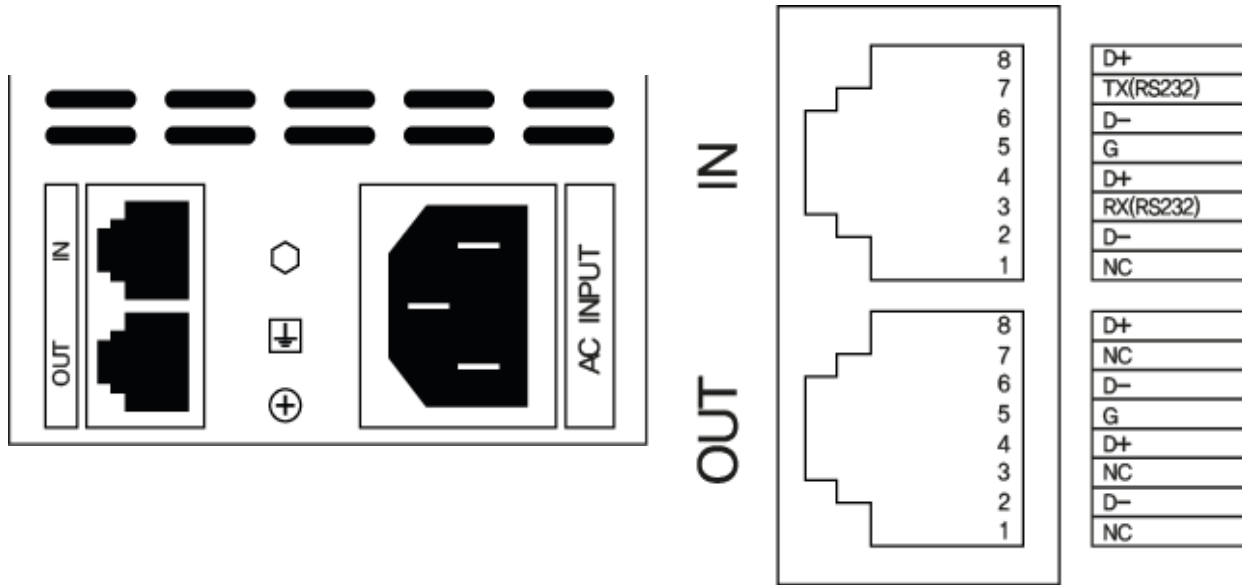

< Figure. 1 >

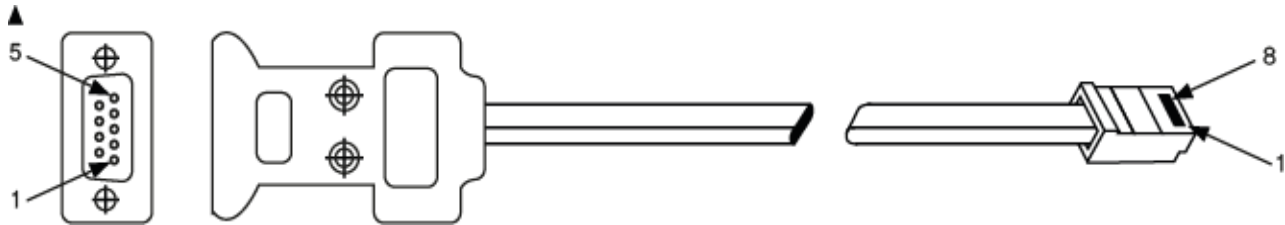

< Figure 2 >

PC Port : DB-9 Connector (Female)	
Pin Number	Name
2	RX
3	TX
5	SG





EX Port : RJ-45 Jack (8pin)	
Pin Number	Name
7	TX
3	RX
5	SG



← → ←

## TCP/IP Setting(Optional)



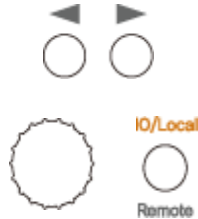
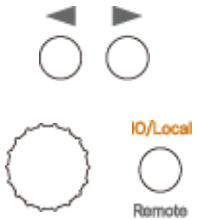

TCP/IP communication module is optional and it is not external installation product. So when you need TCP/IP module, inform us in order to attach it in the power supply .  
 Module speed is 10/100Mbps and intra network PC is standard. Also if you connect the instrument to the fixed IP address, it will automatically obtain an IP address from the network. And you can control the instrument anywhere you are in the world.



\*Fixed IP setting method.

	<ul style="list-style-type: none"> <li>Turn on the power supply After turned on, check the power supply displays "**OUTPUT OFF**" Mode.</li> </ul>
	<ul style="list-style-type: none"> <li>Press "I/O" key in order to set TCP/IP interface. LCD Display <input type="text" value="I/O&gt; 1.RS232C"/> Or it is differ following before state.</li> </ul>
	<ul style="list-style-type: none"> <li>Following before state, appears RS232C, RS485, USB and TCP/IP on the display. If the display is not "4.TCP/IP" press the cursor key until changing to "I/O&gt; 4.TCP/IP" on the display. LCD Display <input type="text" value="I/O&gt; 4.tcp/ip"/></li> </ul>
	<ul style="list-style-type: none"> <li>Press the "I/O Local" key in order to set the TCP/IP. LCD Display <input type="text" value="&gt;1. Static"/> Or it is differ following before state.</li> <li>Setting method is two type. The one is fixed IP and the other is DHCP. Below method is for setting the fixed IP input method directly.</li> </ul>
	<ul style="list-style-type: none"> <li>By using cursor key, set the "1.static" and then press the "IO/Local" key. TCP/IP Port setting must be equal with PC. LCD Display <input type="text" value="&gt;port 5000"/> Or it is differ following before state.</li> </ul>
	<ul style="list-style-type: none"> <li>You can change the device number by using encoder knob.</li> <li>After changed the TCP/IP port by using cursor key and encoder switch, and then press the "IO/Local" key.</li> </ul>
<div style="border: 1px solid black; padding: 2px; display: inline-block;">&gt; local ip input</div> 	<ul style="list-style-type: none"> <li>After appeared "Local IP Input" message for a while, display is changed to IP input screen automatically. LCD Display <input type="text" value="&gt;192.168.123.100"/></li> <li>Input the fixed IP by using cursor key and encoder knob.</li> <li>After finished the inputting, press the "IO/Local" key.</li> </ul>





<div style="border: 1px solid black; padding: 2px; width: fit-content; margin-bottom: 5px;">&gt; subnet input</div>  <div style="border: 1px solid black; padding: 2px; width: fit-content; margin-top: 5px;">&gt;gate way input</div>	<ul style="list-style-type: none"> <li>■ Appear "Subnet Input" message briefly and then, change to subnet mask input screen. LCD Display <span style="border: 1px solid black; padding: 2px 10px;">&gt;255.255.255.0</span></li> <li>■ Input the subnet mask by using cursor and encoder knob.</li> <li>■ After finished inputing, press "IO/Local" key.</li> </ul>
	<ul style="list-style-type: none"> <li>■ Appear "Gateway Input" message briefly and then, change to gateway input screen. LCD Display <span style="border: 1px solid black; padding: 2px 10px;">&gt;192.168.123.254</span></li> <li>■ Input the gateway address by using cursor and encoder knob.</li> <li>■ After finished inputing, press "IO/Local" key.</li> </ul>
	<ul style="list-style-type: none"> <li>■ In order to finish the I/O setting, press the "I/O" key. LCD Display <span style="border: 1px solid black; padding: 2px 10px;">SAVED</span> Through above procedure, interface method is TCP/IP.</li> </ul>

\*DHCP setting method.

	<ul style="list-style-type: none"> <li>■ Turn on the power supply After turned on, check the power supply displays"***OUTPUT OFF**" Mode.</li> </ul>
	<ul style="list-style-type: none"> <li>■ Press "I/O" key in order to set TCP/IP interface. LCD Display <span style="border: 1px solid black; padding: 2px 10px;">I/O&gt; 1.RS232C</span> Or it is differ following before state.</li> </ul>
	<ul style="list-style-type: none"> <li>■ Following before state, appears RS232C, RS485, USB and TCP/IP on the display. If the display is not "4.TCP/IP" press the cursor key until changing to "I/O&gt; 4.TCP/IP" on the display. LCD Display <span style="border: 1px solid black; padding: 2px 10px;">I/O&gt; 4.tcp/ip</span></li> </ul>
	<ul style="list-style-type: none"> <li>■ Press the "I/O Local" key in order to set the TCP/IP. LCD Display <span style="border: 1px solid black; padding: 2px 10px;">&gt;1. Static</span> Or it is differ following before state.</li> <li>■ Setting method is two type. The one is fixed IP and the other is DHPC. Below method is for setting the fixed IP input method directly.</li> </ul>

	<ul style="list-style-type: none"> <li>Set the 2.dhcp by cursor, than prest the IO/Local Key TCP/IP Port set is same with PC. LCD Display &gt;port 5000 Or it is differ following before state</li> </ul>
	<ul style="list-style-type: none"> <li>You can change the device number by using encoder knob.</li> <li>After changed the TCP/IP port by using cursor key and encoder switch, and then press the "IO/Local" key.</li> </ul>
	<ul style="list-style-type: none"> <li>Appear "wait..." message LCD Display <input type="text" value="wait..."/></li> <li>During receiving IP from server, appear "wait..." and it automatically configures the addressing. When selected, the instrument first tries to obtain an IP address from a DHCP server and display the IP address and automatically quit from setting menu. LCD Display <input type="text" value="Local ip is"/> → <input type="text" value="192.168.123.32"/></li> <li>If the instrument did not obtain the IP within a certain period of time, after appeared "Time Out Error" message, automatically quit form menu.</li> </ul>

\* Confirm IP address.





	<ul style="list-style-type: none"> <li>Turn on the power supply After turned on, check the power supply displays"***OUTPUT OFF**" Mode.</li> </ul>
	<ul style="list-style-type: none"> <li>Press "I/O" key in order to set TCP/IP interface. LCD Display <input type="text" value="I/O&gt; 1.RS232C"/> Or it is differ following before state</li> </ul>
	<ul style="list-style-type: none"> <li>Following before state, appears RS232C, RS485, USB and TCP/IP on the display. If the display is not "4.TCP/IP" press the cursor key until changing to "I/O&gt; 4.TCP/IP" on the display. LCD Display <input type="text" value="I/O&gt; 4.tcp/ip"/></li> </ul>
	<ul style="list-style-type: none"> <li>Press the "I/O Local" key in order to confirm IP. LCD Display <input type="text" value="&gt;1. Static"/> Or it is differ following before state.</li> </ul>
	<ul style="list-style-type: none"> <li>Select "3.IP CHECK" by using cursor key. LCD Display <input type="text" value="&gt;3. ip check"/></li> </ul>
	<ul style="list-style-type: none"> <li>When press the "IO/Local" key, appear obtained IP. If you want to quit, press "IO/Local" key LCD Display <input type="text" value="&gt;192.168.123.32"/></li> </ul>

**Note**

Use only standard UTP(LAN) cable.





## Delimiter

You can choose the sending and responding data delimiter among LF, CR and CRLF and when we are shipped, default value is LF. Next is setting procedure

	<p>■ Turn on the power supply After turned on, check the power supply displays "**OUTPUT OFF**" Mode.</p>
	<p>■ In order to change the delimiter, press the "IO/Local" key. LCD Display <input type="text" value="I/O&gt;"/> <i>Or it is differ following before state.</i></p>
	<p>■ Press the cursor key until reaching "5.delimiter". LCD Display <input type="text" value="&gt;delimiter lf"/></p>
	<p>■ If you want to change the delimiter to "CR", press the "IO/Local" key. LCD Display <input type="text" value="delimiter"/> <i>Or it is differ following before state.</i></p>
	<p>■ In order to select "CR", press the cursor key and move to "delimiter cr" After appear "delimiter cr" message, press the "IO/Local" key, after then, appear "SAVED" message. LCD Display <input type="text" value="delimiter"/> → <input type="text" value=""/></p>

## Response

You are able to have the response when you send the commennd to power supply.  
When shipped, response function is clear state.



	<p>■ Turn on the power supply After turned on, check the power supply displays "**OUTPUT OFF**" Mode.</p>
	<p>■ In order to change "Respons" enable or disable, press the "IO/Local" key. LCD Display <input type="text" value="I/O&gt;"/> <i>Or it is differ following before state.</i></p>
	<p>■ Until appearing "6.response", press the cursor key. LCD Display <input type="text" value="I/O&gt;"/></p>
	<p>■ In order to change the "Response" enable, press the "IO/Local" key. LCD Display <input type="text" value="&gt;response"/> <i>Or it is differ following before state.</i></p>
	<p>■ Press the cursor key until appearing "response yes" message. And in order to be enable, press the "IO/Local" key. LCD Display <input type="text" value="response yes"/> → <input type="text" value="SAVED"/></p>

### 3-12. Limit Display





Shows voltage and current limit values on the display and allows knob adjustment for setting limit values. When you press the "Limit Display" key, LMT Lamp is turned on. If it is dark, the power supply is under the readback display or output off state.

Next is setting procedure about limit display

\* Display limit at the "Output OFF" mode.

	<ul style="list-style-type: none"> <li>Turn on the power supply After turned on, check the power supply displays "**OUTPUT OFF**" Mode.</li> </ul>
	<ul style="list-style-type: none"> <li>in order to see the limit of voltage and current, press the "Limit Display" key.</li> </ul>
	<ul style="list-style-type: none"> <li>LMT Lamp is turned on and appear readback voltage and current. LCD Display <span style="border: 1px solid black; padding: 2px;">00.00V 88.00A</span></li> <li>By using encoder knob, you can set the voltage or current.</li> </ul>
	<ul style="list-style-type: none"> <li>After finished to set, press the "Limit Display" key. And return to previous state. LCD Display <span style="border: 1px solid black; padding: 2px;">**output off**</span></li> </ul>

\* Display limit at the "Output ON" mode

	<ul style="list-style-type: none"> <li>Turn on the power supply After turned on, check the power supply displays "**OUTPUT OFF**" Mode.</li> </ul>
	<ul style="list-style-type: none"> <li>in order to see the output of voltage and current, press the "Output On/Off" key. LCD Display <span style="border: 1px solid black; padding: 2px;">00.00V 00.00A</span></li> </ul>
	<ul style="list-style-type: none"> <li>in order to see the limit of voltage and current, press the "Limit Display" key.</li> </ul>
	<ul style="list-style-type: none"> <li>LMT Lamp is turned on and appear readback voltage and current. LCD Display <span style="border: 1px solid black; padding: 2px;">00.00V 88.00A</span></li> <li>By using encoder knob, you can set the voltage or current.</li> </ul>
	<ul style="list-style-type: none"> <li>After finished to set, press the "Limit Display" key. And return to previous state. LCD Display <span style="border: 1px solid black; padding: 2px;">10.00v 00.00a</span> <i>This display is for setting 10V</i></li> </ul>





### 3-13. Store

You can store up to ten different operating states(Output ON/OFF state, Voltage, Current, OVP, OCP, UVL, OVL, UCL, OCL) in non-volatile memory.

The following steps show you howto store an operating state.

Store Key can be used to calibrate the power supply.

About calibration, refer to "4. CALIBRATION".

	<ul style="list-style-type: none"> <li>Turn on the power supply After turned on, check the power supply displays"***OUTPUT OFF**" Mode.</li> </ul>
	<ul style="list-style-type: none"> <li>in order to store operating state in non-volatile, press the "STORE" key.</li> </ul> <p>LCD Display <span style="border: 1px solid black; padding: 2px;">STORE NO, 01</span></p>
	<ul style="list-style-type: none"> <li>Turn the encoder knob to specify the memory location among 01 ~ 10. For examples, turn the knob to the right to specify the memory location 2.</li> </ul> <p>LCD Display <span style="border: 1px solid black; padding: 2px;">STORE NO, 02</span></p>
	<ul style="list-style-type: none"> <li>in order to store in your selected memory location 2, press the "STORE" key.</li> </ul> <p>LCD Display 내용 <span style="border: 1px solid black; padding: 2px;">Saved</span></p>
	<ul style="list-style-type: none"> <li>Appear "Saved" message, and return to previous state.</li> </ul>

» Related Remote Interface Command

\*SAV {1|2|3|4|5|6|7|8|10}

Apply : \*SAV 4 store operating states at location 4 in non-volatile memory.

#### Note

If you store operating state when the power supply output is on, it may give rise to serious trouble when you recall. So. It is safe to store under the output off mode.

#### Note

You can initialize the non-volatile memory. Refer to "5-3. USER-MEM CLEAR".







### 3-14. Recall

You can recall up to ten different operating states(Output ON/OFF state, Voltage, Current, OVP, OCP, UVL, OVL, UCL, OCL) in non-volatile memory.

The following steps show you howto recall an operating state.

Recall Key can be used to FACTORY function.

*Recall Key can be used to FACTORY function.Refer to "5.FACTORY ".*

	<p>■ Turn on the power supply After turned on, check the power supply displays"<b>**OUTPUT OFF**</b>" Mode.</p>
<p>Recall</p>  <p>Factory</p>	<p>■ Press the "RECALL" key in order to recall the stored state.</p> <p>LCD Display <span style="border: 1px solid black; padding: 2px;">RECALL NO, 01</span></p>
	<p>■ Choose the storage location number that you want to apply by using encoder knob. For examples, if you want to apply No.02 state, turn to right one click.</p> <p>LCD Display <span style="border: 1px solid black; padding: 2px;">RECALL NO, 02</span></p>
<p>Recall</p>  <p>Factory</p>	<p>■ in order to recall in your selected memory location 2, press the "RECALL" key.</p> <p>LCD Display 내용 <span style="border: 1px solid black; padding: 2px;">saved</span></p>
	<p>■ Appear "Saved" message, and return to previous state.</p>

» Related Remote Interface Command

*\*RCL {1|2|3|4|5|6|7|8|10}*



*Apply : \*RCL 4 recall operating states at location 4 in non-volatile memory.*

#### Note

*If you store operating state when the power supply output is on, it may give rise to serious trouble when you recall. So. It is safe to store under the output off mode.*

### 3-15. Output ON/OFF

Enables or disables the power supply output. This key toggles between on and off. Therefore you can acquire the effect of output on/off without remove the connected DUT. Proceed as follows.

	<ul style="list-style-type: none"> <li>Turn on the power supply After turned on, check the power supply displays "***OUTPUT OFF**" Mode.</li> </ul>
<p>Output</p> 	<ul style="list-style-type: none"> <li>Basic state is output off mode. in order to enable output on, press the "OUTPUT ON/OFF" key.</li> </ul>
<p>Output</p> 	<ul style="list-style-type: none"> <li>in order to enable output off, press the "OUTPUT ON/OFF" key once more.</li> </ul>

» Related Remote Interface Command

*OUTP {OFF|ON}*

*OUTP?*

*Apply : Check what state is Output and when the power supply output state is off , the method of changing to output on.*

*OUTP? Return value "0" Check the output state.(Value "0" means output off state).*

*OUTP ON Output on.*

#### Note

*If you turn on the power supply and the power supply's default of output state is not output off state, enter to "Factory" Mode and go to "Last State" mode in order to change to disable of "Last State" And then turn off the power supply and turn on the power supply. You can see the appearing the OUTP OFF display.*





### 3-16. Error Message Display

When the front-panel ERROR annunciator turns on, one or more command syntax or hardware errors have been detected. A record of up to 10 errors is stored in the power supply's error.

*About error explanation, refer to "7. Error Messages".*

- Errors are retrieved in first-in-last-out order. The first error returned is the first error that was stored. When you have read all errors from the memory, the ERROR annunciator turns off.
- If more than 10 errors have occurred, the last error stored in the memory. (the most recent error) is replaced.
- When you read the error queue, the most recent error appear in display and erase it from stack.
- Whenever error occurs, sounds the beep and annunciates "ERR" lamp.

#### ERROR Check

	<ul style="list-style-type: none"> <li>■ Turn on the power supply After turned on, check the power supply displays "***OUTPUT OFF**" Mode.</li> </ul>
	<ul style="list-style-type: none"> <li>■ in order to check the error, press the "ERROR" key during 3 seconds. If no error, appears next display and return to previous state.</li> </ul> <p>LCD Display <span style="border: 1px solid black; padding: 2px;">NO ERROR</span> Turn off "ERR" lamp.</p> <p>If exists error, appears next display.</p> <p>LCD Display <span style="border: 1px solid black; padding: 2px;">ERROR NO, -200</span></p>
	<ul style="list-style-type: none"> <li>■ in order to check next error, press the "ERROR" key. If exists error, appears related error display.</li> </ul> <p>LCD Display <span style="border: 1px solid black; padding: 2px;">ERROR NO, -10</span></p>
	<ul style="list-style-type: none"> <li>■ In order to check next error, press the "ERROR" key repeatedly to read the errors stored.</li> </ul>

» Related Remote Interface Command

*SYST:ERR?*

*Apply : Check error*

*SYST:ERR? Return value :-222, "Out of data"*

*You can confirm the error NO. and message.*

#### Note

1. You just check the error number in the front panel. But you can check the error number and message in the remote interface.

2. Stack memory? FILO(First In Last Out) structure, that is as like long length container, so in order to take out first in content, take out all contents included last take in contents.

\*\*\*Queue Memory? FIFO(First In First Out) structure, it is like a pipe that the bottom and top is opened, so if put the content at the top side, the first content go out at the other side.

## 4. CALIBRATION

### *Warning*

The person or institute who not only does not have the acknowledge but also is not certificate calibration center should not calibrate the power supply. If they calibrate the power supply, Do calibration periodically > precision use : one time after 180 days.  
> nomal use : 1 time/one year.

There are some relative error caused by decrepit power supply, circumstance temperature, humidity and various environment. Therefore, if you calibrate bespoke to mentioned circumstance you can use the power supply under optimum.

### 4-1. Characteristics.

- No need to open the power supply cover.
- Be able to calibrate by using front panel key.
- Be able to calibrate by using remote interface.
- Store in non-volatile memory permanently.
- Be able to restore and backup the calibration data.
- Easy to calibrate by comparing between calibration equipment and power supply at a one to one method.

### 4-2. Preparation for Calibration.

- Use more higer precise measuring instrument than the power supply.
- Warming up the power supply and measuring instruments while 1 hour or more at room temperature 20°C ~ 30°C.
- Calibration humidity must be below 80%.
- Connect between the power supply's output bus bar and measuring instrument there are no contact resistance.
- Connect the power supply's GND and measuring instrument's earth terminal with AC input power's GND.
- Block and turn off the magnetic generating and not related calibration devices from the power supply and measuring instruments.

### 4-3. Equipment required for Calibration.

We recommend as below measuring instruments in order to calibrate the power supply.

M/I	Requested performance	Recommended	Using article
Digital Voltmeter	Resolution: 0.1 mV Accuracy: 0.01%	Agilent 34401A	Voltage Calibration
Electronic Load	Voltage Range: 500 Vdc Current Range: 120 Adc Open and Short Switches Transient On/Off		Current calibration for Power Supply (General load resistor is also OK)
Current monitoring	0.001Ω , 0.01%		When current calibration,
Oscilloscope	100 MHz with 20MHz bandwidth	Tektronix TDS3014	Measuring ripple & noise

### 4-4. Technic of Calibration.

As below is for calibration technics.

#### Instruments Connection Drawing.

- Connect as Figure. 4-1.
- When calibrates voltage, turn off the electronic load or remove the connection from output bus bar.
- It is fine to use the general load resistor instead of electronic load.

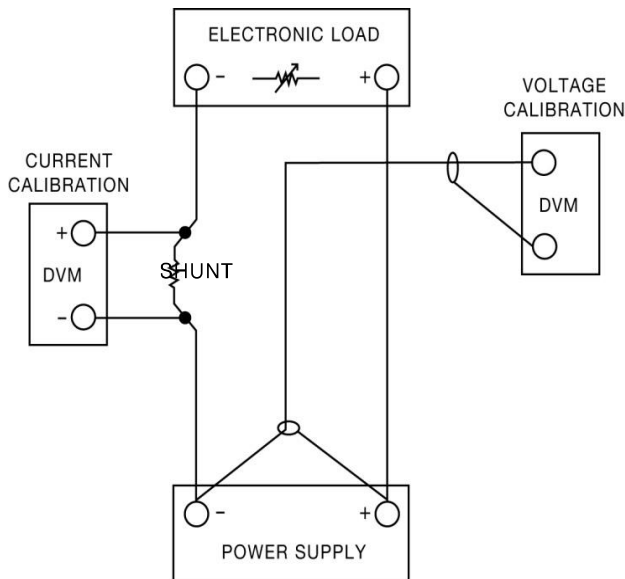

< Figure. 4-1 >

## Electronic Load.

- This instrument is for power supply's current calibration. Electronic load is kind of variable resistor.
- This instrument must have ON/OFF function and itself's short function for testing.
- When current calibration, connect the power supply (+) output terminal and electronic load and connect the power supply (-) output terminal and shunt lead for current monitoring **and then connect shunt's the other lead to electronic load (-) terminal**
- It must be able to communicate to PC.

## Current-Monitoring Resistor(shunt)

- Normally, current measuring instruments is not suitable high current capacity's measuring, so generally, use current monitoring resistor.
- Select shunt that TCR is below 10ppm.
- Select shunt that precision is around 0.01%.

## DVM(Digital Volt Meter)

- It is used for voltage calibration and current monitoring sensing
- It must be, the resolution : 0.1 mV , Accuracy : below 0.01%.
- It must be able to communicate to PC.

## Programming

Our power supply is based on PC interface calibration.

If you use the communication calibration, it is not caused measuring error and also you can measure the accurate calibration data.

Below is PC communication connection drawing.

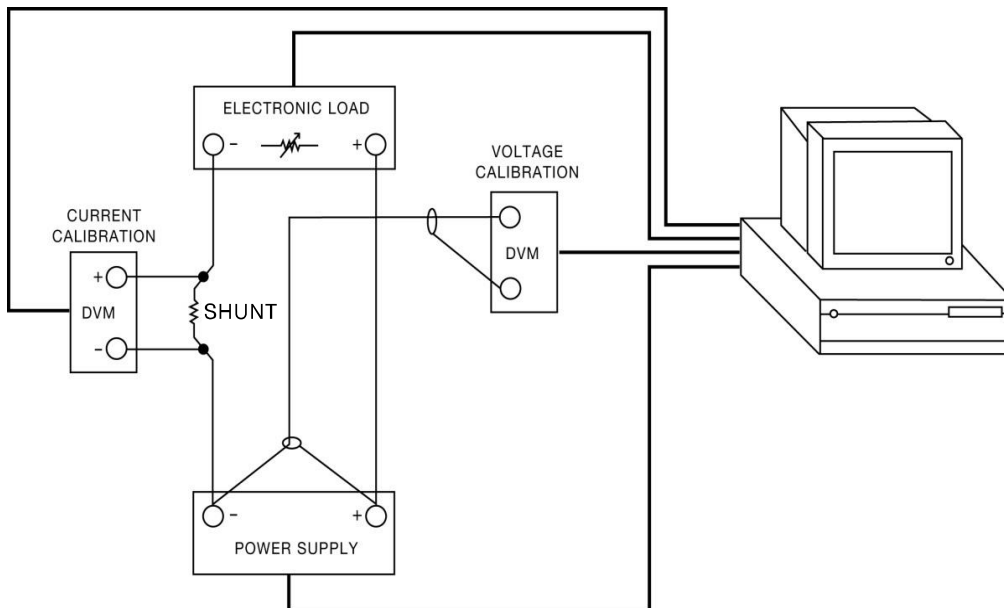

< Figure. 4-2 >







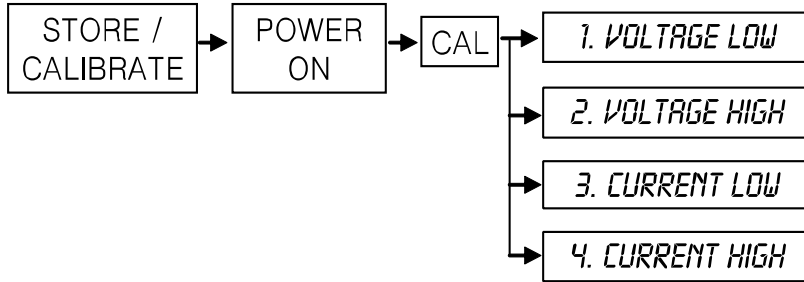











## 4-5. Using Front Panel Calibration.

Below structure is the procedure of using front panel "CALIBRATE Key"



### Calibration Key Structure



## Voltage Calibraton

	<ul style="list-style-type: none"> <li>Turn off all device and connect all device before calibration.</li> <li>&gt;Connect the power supply (+) output bus bar at the DVM (+) and connect the power supply (-) output bus bar at the DVM (-)</li> </ul>
 In a pressing 	<ul style="list-style-type: none"> <li>Power switch on in a pressing calibration key.</li> </ul>
	<ul style="list-style-type: none"> <li>Power switch on.</li> </ul>
 Release 	<ul style="list-style-type: none"> <li>After finished self test, when appearing "1.cal-volt low" message, release calibration key.</li> </ul>
 	<ul style="list-style-type: none"> <li>Press the calibration key in "1.cal-volt low" mode.</li> </ul> <p>LCD Display <span style="border: 1px solid black; padding: 2px;">V-LOW 00.14V</span> <i>Display value Display can be differ.</i></p>
Wait for 5 minute.	<ul style="list-style-type: none"> <li>Wait until DVM display voltage becomes stable.</li> </ul>
    	<ul style="list-style-type: none"> <li>Enters a voltage value that you obtained by reading an external DVM meter. If the value is 151.9mV, enters as following below.</li> </ul> <p>LCD Display <span style="border: 1px solid black; padding: 2px;">V-LOW 00.15V</span> <i>This is an examples for 30 Voltage output power supply.</i></p>
 	<ul style="list-style-type: none"> <li>After finished to enter the value, press the "Calibration" key.</li> </ul> <p>LCD Display <span style="border: 1px solid black; padding: 2px;">ADC datA 026ch</span> <i>During around 500ms, display HEX value instead of readback value</i></p> <p>LCD Display <span style="border: 1px solid black; padding: 2px;">1.cal-volt low</span> <i>Return to before state of Mcalibrating.</i></p>
   	<ul style="list-style-type: none"> <li>Move to "2.cal-volt high" mode by using cursor key and press the "Calibration" key.</li> </ul> <p>LCD Display <span style="border: 1px solid black; padding: 2px;">V-high 31.60V</span> <i>It is able to differ about volt display.</i></p>
Wait for 5 minute.	<ul style="list-style-type: none"> <li>Wait until DVM display voltage becomes stable.</li> </ul>







	<p>■ Enters a voltage value that you obtained by reading an external DVM meter. If the value is 31.618+13478mV, enters as following below.</p> <p>LCD Display <span style="border: 1px solid black; padding: 2px;">V-high 31.61v</span> <i>This is an examples for 30 Voltage output power supply.</i></p>
	<p>■ After finished to enter the value, press the "Calibration" key.</p> <p>LCD Display <span style="border: 1px solid black; padding: 2px;">ADC datA f100h</span> <i>During around 500ms, display HEX value instead of readback value</i></p> <p>LCD Display <span style="border: 1px solid black; padding: 2px;">2.cal-volt high</span> <i>Return to before state of Mcalibrating.</i></p>
	<p>■ It is finish of voltage calibration. You can use the power supply next time. by applyi</p>





## Current Calibration

■ Turn off all device and connect all device before calibration.

>When current calibration, connect the power supply (+) output terminal and electronic load and connect the power supply (-) output terminal and shunt lead for current monitoring and then connect shunt's the other lead to electronic load (-) terminal

>Connect the DVM (+) test lead at the electronic load connction of current monitoring resistor connect the DVM (-) test lead at the other side of current monitoring resistor.

	<p>■ In a pressing calibration key.</p>
	<p>■ Power switch on.</p>
	<p>■ After finished self test, when appearing "1.cal-volt low" message, release calibration key.</p>
	<p>■ Move to "3.cal-curr low" mode by using cursor key and press the "Calibration" key.</p> <p>LCD Display <span style="border: 1px solid black; padding: 2px;">a-LOW 00.14a</span> <i>It is able to differ about volt display.</i></p>
<p>Wait for 5 minute.</p>	<p>■ Wait until DVM display voltage becomes stable.</p>

	<ul style="list-style-type: none"> <li>Calculate the current when DVM display voltage became stable. If resistor is <math>0.01\Omega</math> and DVM display voltage value is <math>1.23\text{mV}</math>, the current value is <math>0.123\text{A}</math>.</li> </ul>
	<ul style="list-style-type: none"> <li>Enters a current value that you calculated by using cursor key and encoder knob. This is an examples for 60 ampere output power supply.</li> </ul> <p>LCD Display <span style="border: 1px solid black; padding: 2px;">a-LOW 00.12a</span></p>
	<ul style="list-style-type: none"> <li>After finished to enter the value, press the "Calibration" key.</li> </ul> <p>LCD Display <span style="border: 1px solid black; padding: 2px;">ADC datA 026ch</span> <i>During around 500ms, display HEX value instead of readback value</i></p> <p>LCD Display <span style="border: 1px solid black; padding: 2px;">3.cal-curr low</span> <i>Return to before state of Mcalibrating.</i></p>
	<ul style="list-style-type: none"> <li>Move to "4.cal-curr High" mode by using cursor key and press the "Calibration" key.</li> </ul> <p>LCD Display <span style="border: 1px solid black; padding: 2px;">a-high 61.00a</span> <i>It is able to differ about curr display.</i></p>
Wait for 5 minute.	<ul style="list-style-type: none"> <li>Wait until DVM display voltage becomes stable.</li> </ul>
	<ul style="list-style-type: none"> <li>Calculate the current when DVM display voltage became stable. If resistor is <math>0.01\Omega</math> and DVM display voltage value is <math>615\text{mV}</math>, the current value is <math>61.50\text{A}</math>.</li> </ul>
	<ul style="list-style-type: none"> <li>Enters a current value that you calculated by using cursor key and encoder knob. This is an examples for 60 ampere output power supply.</li> </ul> <p>LCD Display <span style="border: 1px solid black; padding: 2px;">a-high 61.50a</span></p>
	<ul style="list-style-type: none"> <li>After finished to enter the value, press the "Calibration" key.</li> </ul> <p>LCD Display <span style="border: 1px solid black; padding: 2px;">ADC datA f500h</span> <i>During around 500ms, display HEX value instead of readback value</i></p> <p>LCD Display <span style="border: 1px solid black; padding: 2px;">4.cal-curr high</span> <i>Return to before state of Mcalibrating.</i></p>
	<ul style="list-style-type: none"> <li>It is finish of current calibration. You can use the power supply next time. by applying this data.</li> </ul>

## 4-6. Remote Interface Calibration.

This chapter is for remoting calibration method by using remote interface.

When you calibrate the power supply under remote interface state, you should not set other comr

### Instruments Connection.

- Before calibrating, connect the all devices like <Figure. 4-2>
- Set each measuring instrument's communication state.
- Warming up the power supply and measuring instruments while 1 hour or more at room temperature 20°C ~ 30°C.

### Remote Calibration Command Procedure.

- Refer to SCPI commands of "6-6. Calibration command"
- You must send the commands as next order, if occurs the errors, remote calibration is cancelled.
- If error is occurred, you must restart remote calibration.

### Voltage Calibraton

- Send the "OFF" command to electronic load.
- Send the power supply voltage minimum calibration command.  
Sending `CAL:VOLT MIN`
- After waited for minimum 5 minutes more, measures DVM's voltage.
- Send measured voltage value.  
For examples, if measured voltage value is 0.1234, sends as following.  
Sending `CAL:VOLT 0.1234`
- Send the power supply voltage maximum calibration command.  
Sending `CAL:VOLT MAX`
- After waited for minimum 5 minutes more, measures DVM's voltage.
- Send measured voltage value.  
For examples, if measured voltage value is 30.123, sends as following.  
Sending `CAL:VOLT 30.123`

## Current Calibration.

- Send the "ON" command to electronic load.
- Send the power supply current minimum calibration command.  
Sending `CAL:CURREN MIN`
- The mode of electronic load is CC mode, so set the current value is higher than the power supply's maximum output ampere value. If you send the current calibration value is lower than the power supply's maximum ampere value, this is CV mode and wrong calibration value is measured and saved at the power supply. So remind to set the sending value is higher than power supply's maximum output ampere.
- After waited for minimum 5 minutes more, measures DVM's voltage that is connected with current monitoring resistor.
- Send calculated current value that prepared current value calculating program calculated  
For examples, if calculated current value is 0.1234, sends as following.  
  
Sending command `CAL:CURREN 0.1234`
- Send the power supply current maximum calibration command.  
Sending command `CAL:CURREN MAX`
- After waited for minimum 5 minutes more, measures DVM's voltage that is connected with current monitoring resistor.
- Send calculated current value that prepared current value calculating program calculated  
For examples, if calculated current value is 60.553, sends as following.  
Sending command `CAL:CURREN 60.553`

## 5. FACTORY

You can set the various convenient function as following calibration restore, backup and etc. by using "FACTORY" mode.

### 5-1. Characteristic.

- Be able to initialize the 10 non-volatile memory datas as like OVP, OCP and etc.
- Be able to recall the state that is before state of the power supply power off.
- Be able to change to minimum value of voltage/current value automatically if you are not use the power supply long time.
- Be able to lock the power supply's front-panel if you are not set the power supply after set and just outputs the DC source.
- Be able to disable the OVP, OCP protection function.
- Be able to set the average value of voltage/current.
- Be able to backup and restore calibration and be back to before the state of power supply was shipped from ODA Technologies factory.



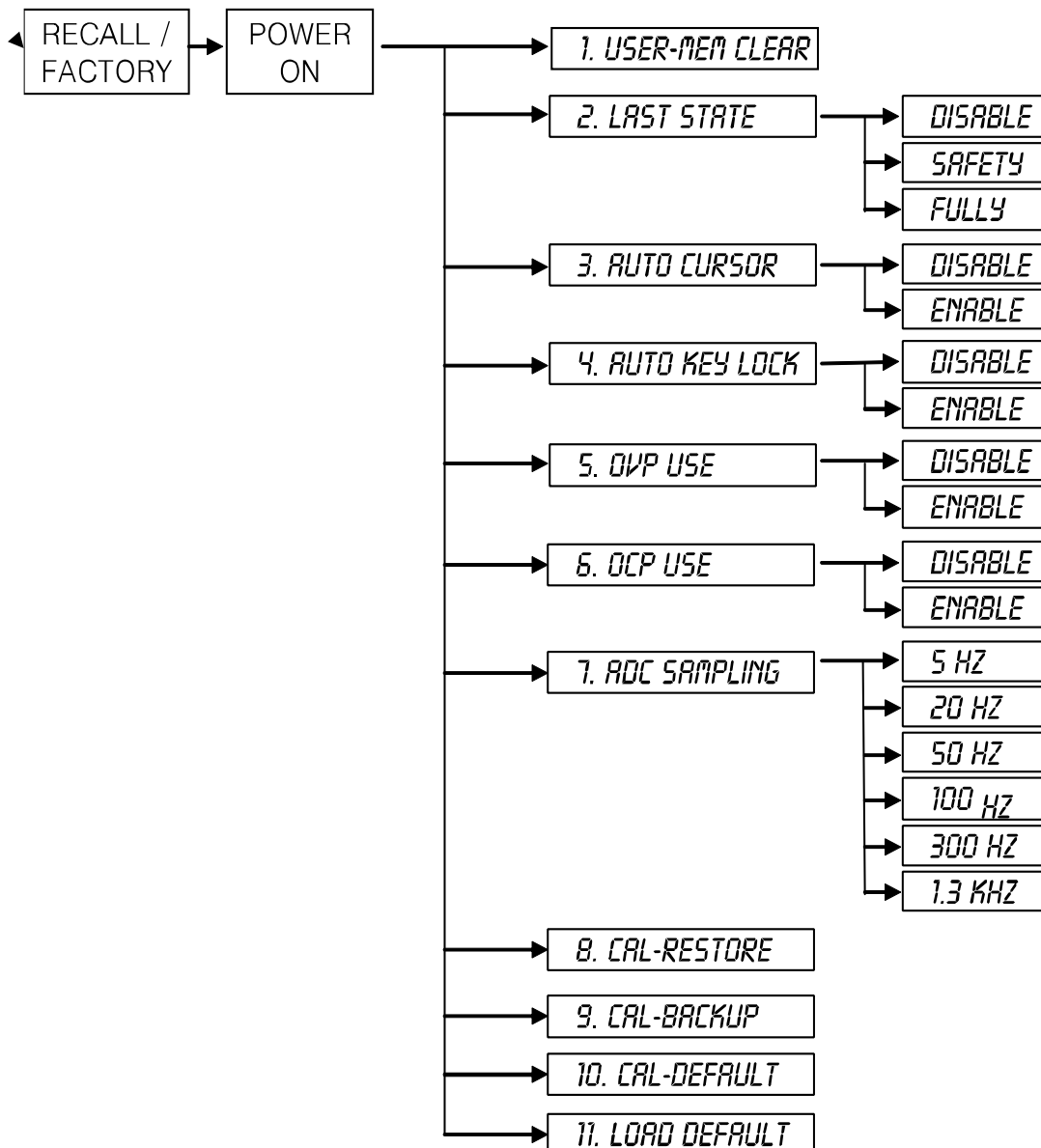

### 5-2. Factory Key Structure.



### 5-3. USER-MEM CLEAR

- This mode is to initialize the 10 datas of OVP, OCP, UVL and etc in the non-volatile memory at once.
- After initialized the datas of non-volatile, initialized data never be recovered.
- Initialized contents.
  - >Voltage 0V
  - >Current Limit maximum value.
  - >OVP-Level OVP setting maximum value.
  - >OCP-Level OCP setting maximum value.
  - >UVL-Level 0V
  - >OVL-Level Limit maximum value.
  - >UCL-Level 0A
  - >OCL-Level Limit maximum value.
  - >Output Mode OFF

#### User-Memory Clear Operating

	<p>■ In a pressing "FACTORY" key.</p>
	<p>■ Power switch ON</p>
	<p>■ When appearing "1. user-mem clear" message, release "FACTORY" key.</p>
	<p>■ in order to initialize non-volatile memory datas, press the "FACTORY" key one more time.</p> <p>LCD Display <span style="border: 1px solid black; padding: 2px;">done</span></p>

» Related Remote Interface Command







*FACT:USER-CLE*

*Apply: FACT:USER-CLE Initialize non-volatile memory data.*

## 5-4. LAST STATE

- When you turn on the power supply, you can select the default state of output DC power.
- Function.
  - > DISABLE     When selected this mode, boot the power supply to original default value. For the safety, recommend this mode. When you turn on, appears "OUTPUT OFF" display and you press the OUTPUT key, appears "00.00V 00.00A" display
  - > SAFETY      When you turn on the power supply, appears "OUTPUT OFF" display. But if you press the "OUTPUT" key, recall the last state voltage/current value. If you set the power supply in "10.50V, 40A", the power supply save this value and when you press "OUTPUT" key, the power outputs it.
  - > FULLY       Recall the state before you turn off fully. If you set the voltage 12.00V, current 40.00A, and turn off the power, and turn on the power, after run the self-test, recalls before (appears "12.00V 00.00A" and output state is on).

### Last State Operating.

 In a pressing	<ul style="list-style-type: none"> <li>■ Power switch on in a pressing "FACTORY" key.</li> </ul>
 POWER ON/OFF	<ul style="list-style-type: none"> <li>■ Power switch ON</li> </ul>
 Released	<ul style="list-style-type: none"> <li>■ When appearing "1. user-mem clear" message, release "FACTORY" key.</li> </ul>
	<ul style="list-style-type: none"> <li>■ Enter to "2. last state" mode by using cursor key.</li> </ul>
 Factory	<ul style="list-style-type: none"> <li>■ in order to set, press the "FACTORY" key one more time.</li> </ul> LCD Display <input type="text" value="disable"/>
	<ul style="list-style-type: none"> <li>■ Set the "SAEFTY" mode by using cursor key.</li> </ul> LCD Display <input type="text" value="safety"/>
 Factory	<ul style="list-style-type: none"> <li>■ To finish the last state mode, press the "FACTORY" key one more time.</li> </ul> LCD Display <input type="text" value="done"/>

» Related Remote Interface Command

*FACT:LAST-STA {DIS/SAF/FUL}*

*FACT:LAST-STA?*

*Return Value(DISABLE, SAFETY, FULLY)*

*Apply: FACT:LAST-STA?*

*Return value : FULLY*

*Last state mode is "FULLY"*

*FACT:LAST-STA DIS*







*Last state became to*

*DISABLE mode.*

## 5-5. AUTO CURSOR MV

- If the power supply doesn't receive any operation by using front-panel within a certain period of time, the power supply's cursor location go down to minimum changing unit automatically when you set the "AUTO CURSOR MV" mode is enable.
- After passed long time, if a operator turns encoder knob by mistake, cursor location of voltage and current is at minimum unit position, so it can reduce the DUT damage.
- Function.
  - > DISABLE    Disable "AUTO CURSOR MV" mode.
  - > ENABLE    Enable "AUTO CURSOR MV" mode.

### AUTO CURSOR MV Operating

 Recall Factory In a pressing	<ul style="list-style-type: none"> <li>■ Power switch on in a pressing "FACTORY" key.</li> </ul>
	<ul style="list-style-type: none"> <li>■ Power switch ON</li> </ul>
 Recall Factory Release	<ul style="list-style-type: none"> <li>■ When appearing "1. user-mem clear" message, release "FACTORY" key.</li> </ul>
	<ul style="list-style-type: none"> <li>■ Enter to "3. AUTO CURSOR MV" mode by using cursor key.</li> </ul>
 Recall Factory	<ul style="list-style-type: none"> <li>■ in order to set, press the "FACTORY" key one more time.            LCD Display    <input type="text" value="disable"/></li> </ul>
	<ul style="list-style-type: none"> <li>■ Set the "enable" mode by using cursor key.            LCD Display    <input type="text" value="enable"/></li> </ul>
 Recall Factory	<ul style="list-style-type: none"> <li>■ To finish the "AUTO CURSOR" mode, press the "FACTORY" key one more time.            LCD Display    <input type="text" value="done"/></li> </ul>

» Related Remote Interface Command

*FACT:AUTO-CUR {DIS/ENA}*

*FACT:AUTO-CUR?                      Return Value(0,1)*

*Apply: FACT:AUTO-CUR?              Return value : 1*

*FACT:AUTO-CUR DIS*







*"AUTO CURSOR" mode is enable state  
 AUTO CURSOR mode changed to  
 disable state*



## 5-6. AUTO KEY LOCK

- If the power supply doesn't receive any operation by using front-panel within a certain period of time, the power supply becomes the key lock state automatically when you set the AUTO KEY LOCK mode is enable.
  - It is safe from another person's mistake touch of the power supply front-panel.
  - If the power supply entered under the "AUTO KEY LOCK" mode, the power supply can be controlled by front-panel when after pressed the "Key Lock" button and turned off "LOCK" lamp
- > DISABLE    Disable "AUTO KEY LOCK" mode.
- > ENABLE    Enable "AUTO KEY LOCK" mode.

### AUTO KEY LOCK Operating.

 Recall In a pressing Factory	■ Power switch on in a pressing "FACTORY" key.
 POWER ON/OFF	■ Power switch ON
 Recall Release Factory	■ When appearing "1. user-mem clear" message, release "FACTORY" key.
	■ Enter to "3. AUTO KEY LOCK" mode by using cursor key.
 Recall Factory	■ in order to set, press the "FACTORY" key one more time. LCD Display <input type="text" value="disable"/>
	■ Set the "enable" mode by using cursor key. LCD Display <input type="text" value="enable"/>
 Recall Factory	■ To finish the "AUTO KEY LOCK" mode, press the "FACTORY" key one more time. LCD Display <input type="text" value="done"/>

» Related Remote Interface Command

*FACT:AUTO-LOC {DIS|ENA}*

*FACT:AUTO-LOC?                      Return Value(0, 1)*

*Apply: FACT:AUTO-LOC?              Return value : 1*

*FACT:AUTO-LOC DIS*







*AUTO KEY LOCK mode is enable state  
 AUTO KEY LOCK" mode changed to  
 disable state*



## 5-8. OCP USE

- Enable or disable the "Over Current Protection" function.
- In case of a like inductivity DUT, motor, big capacity DUT and etc, occurs "OCP trip" frequently so if it is not convenient to use the power supply, you can set disable of "OCP USE" mode.
- If disable the "OCP USE", the power supply doesn't cut the DC source when current level is over OCP setting level.
- Function
  - > DISABLE    Disable "OCP USE" mode.
  - > ENABLE    Enable "OCP USE" mode.

### OCP USE

 In a pressing Factory	<ul style="list-style-type: none"> <li>■ Power switch on in a pressing "FACTORY" key.</li> </ul>
 POWER ON/OFF	<ul style="list-style-type: none"> <li>■ Power switch ON</li> </ul>
 Release Factory	<ul style="list-style-type: none"> <li>■ When appearing "1. user-mem clear" message, release "FACTORY" key.</li> </ul>
	<ul style="list-style-type: none"> <li>■ Enter to "6. OCP USE" mode by using cursor key.</li> </ul>
 Factory	<ul style="list-style-type: none"> <li>■ in order to set, press the "FACTORY" key one more time. LCD Display <input type="text" value="enable"/></li> </ul>
	<ul style="list-style-type: none"> <li>■ Set the "enable" mode by using cursor key. LCD Display <input type="text" value="disable"/></li> </ul>
 Factory	<ul style="list-style-type: none"> <li>■ To finish the "OCP USE" mode, press the "FACTORY" key one more time. LCD Display <input type="text" value="done"/></li> </ul>

» Related Remote Interface Command

*FACT:OCP {DIS/ENA}*

*FACT:OCP?*

*Return Value(1, 0)*

*Apply: FACT:OCP?*

*Return value : 0*

*FACT:OCP ENA*

*OCP USE mode is disable state*







*OCP USE mode changed to*

*enable state*

## 5-9. ADC SAMPLING

- Be able to set the output voltage/current measuring speed and displaying speed.
- If the frequency is lower, data acquisition is reduced. But you can get the more accurate value.
- If the frequency is higher, data acquisition is increased. But voltage/current measuring value can be changeable frequently in the display.
- In case of PC interface control, recommends ADC sampling speed is 20~50Hz.
- In case of Front-panel control, recommends ADC sampling speed is 5~20Hz.
- CAUTION : If you have to acquire the voltage/current in high speed 100Hz, 300Hz, use 1.3KHz speed!!
- Function.
  - > 5Hz Measures voltage/current at every 200ms.
  - > 20Hz Measures voltage/current at every 50ms.(Instrument default value)
  - > 50Hz Measures voltage/current at every 20ms.
  - > 100Hz Measures voltage/current at every 10ms.
  - > 300Hz Measures voltage/current at every 3.3ms.
  - > 1.3KHz Measures voltage/current at every 770us.

### ADC SAMPLING

 Recall In a pressing Factory	■ Power switch on in a pressing "FACTORY" key.
 POWER ON/OFF	■ Power switch ON
 Recall Release Factory	■ When appearing "1. user-mem clear" message, release "FACTORY" key.
	■ Enter to "7. adc sampling" mode by using cursor key.
 Recall Factory	■ in order to set, press the "FACTORY" key one more time. LCD Display <input type="text" value="20hz"/>
	■ Set the "50Hz" mode by using cursor key. LCD Display <input type="text" value="50hz"/>
 Recall Factory	■ To finish the "ADC SAMPLING" mode, press the "FACTORY" key one more time. LCD Display <input type="text" value="done"/>

» Related Remote Interface Command

*FACT:ADC {5/20/50/100/300/1300}*

*FACT:ADC? Return Value(5Hz, 20Hz, 50Hz, 100Hz, 300Hz, 1.3KHz)*

*Apply: FACT:ADC 100*

*Set 100Hz speed in order to acquire the data.*





*FACT:ADC? Return value : 100Hz*

*Confirm the ADC sampling speed : 100Hz.*

## 5-10. CAL-RESTORE

- This function is restoring saved calibration data by backup function at present system.
- You can use this function when the person who have no previous knowledge of calibration operates calibration of the power supply or have an error about calibrtion, and you can return to previous calibration data.

### CAL-RESTORE Operating





 In a pressing Factory	<ul style="list-style-type: none"> <li>■ Power switch on in a pressing "FACTORY" key.</li> </ul>
 POWER ON/OFF	<ul style="list-style-type: none"> <li>■ Power switch ON</li> </ul>
 Release Factory	<ul style="list-style-type: none"> <li>■ When appearing "1. user-mem clear" message, release "FACTORY" key.</li> </ul>
	<ul style="list-style-type: none"> <li>■ Enter to "8. CAL-RESTORE" mode by using cursor key.</li> </ul>
 Factory LCD Display <span style="border: 1px solid black; padding: 2px;">done</span>	<ul style="list-style-type: none"> <li>■ in order to restore, press the "FACTORY" key one more time.</li> </ul>

» no Related Remote Interface Command

## 5-11. CAL-BACKUP

- Recommended calibration interval is 6 monthes and in order to precision of the power supply, you must calibrate this unit at the certificated calibration center. Annual calibration is recommended in order to use this unit without problem about calibration.
- If operated to back-up, you can recover to previous back-up data.

### CAL-BACKUP Operating





 In a pressing Factory	<ul style="list-style-type: none"> <li>■ Power switch on in a pressing "FACTORY" key.</li> </ul>
 POWER ON/OFF	<ul style="list-style-type: none"> <li>■ Power switch ON</li> </ul>
 Release Factory	<ul style="list-style-type: none"> <li>■ When appearing "1. user-mem clear" message, release "FACTORY" key.</li> </ul>
	<ul style="list-style-type: none"> <li>■ Enter to "8. CAL-BACKUP" mode by using cursor key.</li> </ul>
 Factory LCD Display <span style="border: 1px solid black; padding: 2px;">done</span>	<ul style="list-style-type: none"> <li>■ in order to back-up, press the "FACTORY" key one more time.</li> </ul>

» no Related Remote Interface Command

## 5-12. CAL-DEFAULT

- This function is to restore to the state of calibration data that shipped from factory.
- If you calibrate the unit in the condition that you have no previous knowledge of calibration or you can not restore by using "5-10. CAL-RESTORE" function, you can return to factory default calibration data. If you use this function, you must calibrate this unit at the official calibration center.

### CAL-DEFAULT Operating





 In a pressing Factory	<ul style="list-style-type: none"> <li>■ Power switch on in a pressing "FACTORY" key.</li> </ul>
 POWER ON/OFF	<ul style="list-style-type: none"> <li>■ Power switch ON</li> </ul>
 Release Factory	<ul style="list-style-type: none"> <li>■ When appearing "1. user-mem clear" message, release "FACTORY" key.</li> </ul>
	<ul style="list-style-type: none"> <li>■ Enter to "10. CAL-DEFAULT" mode by using cursor key.</li> </ul>
 Factory LCD Display <span style="border: 1px solid black; padding: 2px;">done</span>	<ul style="list-style-type: none"> <li>■ in order to restore, press the "FACTORY" key one more time.</li> </ul>

» 관련 Remote Interface Command 없음

## 5-13. LOAD DEFAULT

- This function is to return to default value that shipped the unit from factory. You can erase setting and changing all value at the "Factory Mode"
- Initializing contents.
  - > User Memory Clear    > Last State : Disable    > Auto Cursor Move : Disable
  - > Auto Key Lock : Disable > OVP Use : Enable    > OCP Use : Enable    > ADC Sampling : 20Hz

### LOAD DEFAULT Operating

 In a pressing Factory	<ul style="list-style-type: none"> <li>■ Power switch on in a pressing "FACTORY" key.</li> </ul>
 POWER ON/OFF	<ul style="list-style-type: none"> <li>■ Power switch ON</li> </ul>
 Release Factory	<ul style="list-style-type: none"> <li>■ When appearing "1. user-mem clear" message, release "FACTORY" key.</li> </ul>
	<ul style="list-style-type: none"> <li>■ Enter to "11. LOAD DEFAULT" mode by using cursor key.</li> </ul>
 Factory LCD Display <span style="border: 1px solid black; padding: 2px;">done</span>	<ul style="list-style-type: none"> <li>■ in order to return to default value, press the "FACTORY" key one more time.</li> </ul>

» Related Remote Interface Command

*FACT:LOAD-DEF*

*Apply : FACT:LOAD-DEF*

*Initialize all the factory setting value.*

## 6. SCPI Command.

This section summarizes the SCPI (Standard Commands for Programmable Instruments) commands available to program the power supply over the remote interface. By using interface as following RS232C, RS485, USVB and TCP/IP (Option) you can control the devices so it is fit to F.A system and research center.

### 6-1. Commands Syntax

- Be able to skip small English letter.
- Be able to use the command of capital/small letter.
- It is no limit about quantity of blank (20H) or tap(09H) and set minimum 1 more.
- Command sending is one step at a time.
- A square brackets([ ]) is option or parameters and you can skip it.
- You can not skip the parameter in braces({ }).
- Triangle brackets (< >) indicate that you must substitute a value or a code(examples, MIN, MAX) for the enclosed parameter.
- A vertical bar ( | ) separates one of two or more alternative parameters.
- Command finish suffix is LF(0AH) and you can change to CR, CRLF.
- Maximum character of one time are 40 Byte.
- Commands will be proceeded by "ODA" + 1byte address(01H ~ FFH) + SCPI Protocol in RS 485
- Return character string in Query in RS485 will be same with RS232C. (not include address)

### 6-2. Commands

#### Output Setting Commands

```
APPLY {<voltage>}[,<current>] VOLT:UVL {<numeric value>}
APPLY? VOLT:UVL?
VOLT {<voltage>|UP|DOWN} VOLT:OVL {<numeric value>}
VOLT? VOLT:OVL?
VOLT:STEP {<numeric value>}
VOLT:STEP?
VOLT:OVP {<numeric value>}
VOLT:OVP?
VOLT:OVP:TRIP?
VOLT:OVP:CLE?

CURR {<current>|UP|DOWN} CURR:UCL{<numeric value>}
VOLT? CURR:UCL?
CURR:STEP {<numeric value>} CURR:OCL{<numeric value>}
CURR:STEP? CURR:OCL?
CURR:OCP {<numeric value>}
CURR:OCP?
CURR:OCP:TRIP?
CURR:OCP:CLE?

FLOW?
POL {P|N}
POL?
```

### Measurement Commands

MEAS:CURRE?  
MEAS:VOLT?  
MEAS:ALL?

### Calibration Commands

CAL:VOLT {voltage|MIN|MAX}  
CAL:CURRE {current|MIN|MAX}

### Factory Commands

FACT:USER-M {CLR}  
FACT:LAST-STA {DIS|SAF|FUL}  
FACT:LAST-STA?  
FACT:AUTO-CUR {DIS|ENA}  
FACT:AUTO-CUR?  
FACT:AUTO-LOC {DIS|ENA}  
FACT:AUTO-LOC?  
FACT:OVP {DIS|ENA}  
FACT:OVP?  
FACT:OCP {DIS|ENA}  
FACT:OCP?  
FACT:ADC {5|20|50|100|300|1300}  
FACT:ADC?  
FACT:LOAD-DEF

### System Commands

SYST:BEEP  
SYST:ERR?  
SYST:VERS?

OUTP {OFF|ON}  
OUTP?

KEYL {OFF|ON}  
KEYL?

\*IDN?  
\*SN?  
\*RST  
\*SAV {1|2|3|4|5|6|7|8|10}  
\*RCL {1|2|3|4|5|6|7|8|10}  
\*CLS



### 6-3. Apply Commands.

The APPLY command provides to control the output voltage and current by remote interface.

#### APPLY {<voltage>}[,<current>]

This command can control voltage and current, also for voltage only.

- > voltage Input voltage value
- > current Input current value

ex1) APPL 30,5 *Voltage is 30V, current is 5A.*

ex2) APPL 5 *Just set voltage to 5V excepted current set.*

**Only the APPLY? will instruct the power supply to send a response message about voltage and current value. Between return value, the former is voltage value, the latter is current. Return value "voltage,current"**

ex) APPL? *return value "30.0000,5.0000"*

### 6-4. Output V/I Setting & Operating Commands.

This section describes low-level commands used to program the power supply. Although the APPLY command provides the most straightforward method to program the power supply, the low-level output setting commands give you more flexibility to change the individual parameters.

#### VOLT {<voltage>|UP|DOWN}

This command programs the immediate voltage level of the power supply. The immediate level is the voltage value of the output terminals.

This command also increases or decreases the immediate voltage level using the "UP" or "DOWN" parameter by a predetermined amount. The command VOLTage:STEP sets the amount of increase or decrease.

- > Voltage Input voltage value.
- > UP Increase voltage setting value as step value.
- > DOWN Decrease voltage setting value as step value.

ex1) volt 10 *Set the voltage 10V.*

ex2) volt up *Increase voltage setting value as step value..*

#### Note

If you operated "\*RST" command, voltage step value returned to the unit's default value.  
*About "\*RST" command, refer to "\*RST" command chapter.*

#### VOLT?

This query returns the presently programmed voltage level of the power supply.

Return value "voltage"

ex) volt? *return value "30.0000"*

#### VOLT:STEP {<numeric value>}

This command sets the step size for voltage programming with the VOLTage UP and VOLTage DOWN commands.

- > numeric value Program the power supply to the allowed setting value resolution.

ex) volt:step 0.5 *Set the voltage to 0.5V.*

### VOLT:STEP?

This query returns the value of the step size currently specified. The returned parameter is a numeric value.

Return value "numeric value"

ex) volt:step? *return value "0.5000"*

### VOLT:OVP {<numeric value>}

This command sets the voltage level at which the overvoltage protection circuit will trip.

> numeric value Input voltage within OVP setting range.

ex) volt:ovp 32 *Set the OVP Level to 32V.*

### VOLT:OVP?

This query returns the overvoltage protection trip level presently programmed.

Return value "numeric value"

ex) *return value "32.0000"*

### VOLT:OVP:TRIP?

This query returns a "1" if the overvoltage protection circuit is tripped and not cleared or a "0" if not tripped.

Return value 0 – not tripped state.

1 – OVP Trip state and cut the output.

ex) volt:ovp:trip *return value "1"*

### VOLT:OVP:CLE

This command causes the overvoltage protection circuit to be cleared

Before release trip, refer to "3-4. Programming Over Voltage Protection(OVP)" in order to check the reason of trip occurring and remove this reason.

ex) volt:ovp:cle *Clear the OVP Trip.*

### **Note**

When appears OVP Trip, cut the voltage/current output. At that time, if you set the voltage/current, it can be set. But DC output is still cut unless release the trip mode.

### VOLT:UVL {<numeric value>}

This command sets the under voltage limit level.

> numeric value    0V ~ currently setting value.(up to voltage setting value).

ex) volt 10        *At first set the voltage value.*  
    volt:uvl 5     *Set lower value than above setting value.*  
                    *From the time set UVL, you can not set the voltage to below 5volt.*

### VOLT:UVL?

This query returns the under voltage limit value presently programmed.

Return value    "numeric value"

ex) volt:uvl?     *return value "5.0000"*

### VOLT:OVL?

This command sets the over voltage limit level.

> numeric value    Currently setting value~mixture of limit value.

ex) volt 10        *At first set the voltage value.*  
    volt:ovl 15     *Set higher value than above setting value.*  
                    *From the time set OVL, you can not set the voltage to above 15volt.*

### VOLT:OVL?

This query returns the over voltage limit value presently programmed.

Return value    "numeric value"

ex) volt:ovl?     *return value "15.0000"*

### CURR {<current>|UP|DOWN}

This command programs the immediate current level of the power supply. The immediate level is the current value of the output terminals.

This command also increases or decreases the immediate current level using the "UP" or "DOWN" parameter by a predetermined amount. The command CURRENT:STEP sets the amount of increase or decrease.

> current    Input current value.  
> UP        Increase current setting value as step value.  
> DOWN     Decrease current setting value as step value.

ex1) curr 4.5     *Set the current 4.5A.*  
ex2) curr up     *Increase current setting value as step value..*

---

#### Note

If you operated "\*RST" command, current step value returned to the unit's default value.  
About "\*RST" command, refer to "\*RST" command chapter.

---

### **CURR?**

This query returns the presently programmed current level of the power supply.

Return value "current"

Return value "current"

ex) curr? *return value "4.5000"*

### **CURR:STEP {<numeric value>}**

This command sets the step size for current programming with the CURRent UP and CURRent DOWN commands.

> numeric value Program the power supply to the allowed setting value resolution.

ex) curr:step 0.1 *Set the voltage to 0.5A .*

### **CURR:STEP?**

This query returns the value of the step size currently specified. The returned parameter is a numeric value.

Return value "numeric value"

ex) curr:step *return value "0.5000"*

### **CURR:OCP {<numeric value>}**

This command sets the current level at which the overcurrent protection circuit will trip.

> numeric value Input current within OVP setting range.

ex) curr:ocp 5.2 *Set the OVP Level to 5.2A*

### **CURR:OCP?**

This query returns the overcurrent protection trip level presently programmed.

Return value "numeric value"

ex) curr:ocp? *return value "5.2000"*

### **CURR:OCP:TRIP?**

This query returns a "1" if the overcurrent protection circuit is tripped and not cleared or a "0" if not tripped.

Return value "0" – not tripped state.

"1" – OCP Trip state and cut the output.

ex) curr:ocp:trip? *return value "1"*

### **CURR:OCP:CLE**

This command causes the overcurrent protection circuit to be cleared

Before release trip, refer to "3-4. Programming Over Current Protection(OVP)" in order to check the reason of trip occurring and remove this reason.

ex) curr:ocp:cle *Clear the OCP Trip.*

### **Note**

When appears OCP Trip, cut the voltage/current output. At that time, if you set the voltage/current, it can be set. But DC output is still cut unless release the trip mode.

**CURR:UCL {<numeric value>}**

This command sets the under current limit level.

> numeric value    0V ~ currently setting value.(up to current setting value).

ex) curr 10        *At first set the current value.*

    curr:ucl 5     *Set lower value than above setting value.*

*From the time set UCL, you can not set the current to below 5ampere.*

**CURR:UCL?**

This query returns the under current limit value presently programmed.

Return value    "numeric value"

ex) curr:ucl?     *return value "5.0000"*

**CURR:OCL {<numeric value>}**

This command sets the over current limit level.

> numeric value    Currently setting value~mixture of limit value.

ex) curr 10        *At first set the current value.*

    curr:ocl 15    *Set higher value than above setting value.*

*From the time set OCL, you can not set the current to above 15ampere*

**CURR:OCL?**

This query returns the over current limit value presently programmed.

Return value    "numeric value"

ex) curr:ocl?     *return value "15.0000"*

### FLOW?

This command is for confirming the power supply's CV(Constant Voltage), CC(Constant Current) state.

Return value "CV" – Constant Voltage state.  
"CC" – Constant Current state.

ex) FLOW? *return value "CV"*

### POL {P|N}

This command serves for specialized polarity power supply and changing polarity of output.

> P Convert to positive output state.  
> N Convert to negative output state.

ex) POL P *Convert to positive output state.*

### POL?

This command serves for confirming the power supply's output polarity state.

Return value "P" – positive output state.  
"N" – negative output state.

ex) POL? *return value "P"*

## 6–5. Measure Commands

Measure commands measure the output voltage or current. MEASure commands acquire new data before returning the reading. Also you don't need DVM(Digital Volt Meter) and ammeter and you can measure voltage and current independently.

### MEAS:VOLT?

These queries perform a measurement and return the DC output voltage in volts.

Return value "voltage"

ex) meas:volt? *return value "11.0000"*

### MEAS:CURR?

These queries perform a measurement and return the DC output current in amperes.

Return value "current"

ex) meas:curr? *return value "1.0000"*

### MEAS:ALL?

These queries perform a measurement and return the DC output current in amperes and DC output voltage in volts.

Return value "voltage,current"

ex) meas:all? *return value "10.0000,1.0000" //measured value of 10V, 1A.*

## 6-6. Calibration Commands

Calibration commands let you enable and disable the calibration mode, calibrate current and voltage programming, and store new calibration constants in nonvolatile memory by remote interface.

### **CAL:VOLT {voltage|MIN|MAX}**

This command is for voltage calibration.  
Be careful calibration procedure.

*Refer to "4-6. Remote Interface Calibration".*

- > voltage This command save the calibration measuring voltage value in MIN band and MAX band.
- > MIN Calibrate low band voltage calibration.
- > MAX Calibrate low band voltage calibration.

ex) Following procedure is for voltage calibration order sample.

```
CAL:VOLT MIN    Calibrate low value of voltage.
CAL:VOLT voltage Sending measured voltage value by DVM.
CAL:VOLT MAX    After calibrated low value, so calibrate high value of voltage.
CAL:VOLT voltage Sending measured voltage value by DVM.
                After sended Min or Max and then send voltage value, automatically
                saved the calibration data in the non-volatile memory.
```

### **CAL:CURRE {current|MIN|MAX}**

This command is for current calibration.  
Be careful calibration procedure.

*Refer to "4-6. Remote Interface Calibration".*

- > current This command save the calibration measuring current value in MIN band and MAX band.
- > MIN Calibrate low band current calibration.
- > MAX Calibrate low band current calibration.

ex) Following procedure is for current calibration order sample.

```
CAL:CURRE MIN   Calibrate low value of current.
CAL:CURRE current Sending measured current value by DVM.
CAL:CURRE MAX   After calibrated low value, so calibrate high value of current.
CAL:CURRE current Sending measured current value by DVM.
                After sended Min or Max and then send current value, automatically
                saved the calibration data in the non-volatile memory.
```

## 6-7. Factory Commands

Outside of calibration recovery, you can set various convenient 10 functions.

### **FACT:USER-M {CLR}**

This mode is to initialize the 10 datas of OVP, OCP, UVL and etc in the non-volatile memory at once. After initialized the datas of non-volatile, initialized data never be recovered.

About more information of "User memory clear", refer to "5-3. USER-MEM CLEAR".

- > CLR Initialize the non-volatile memory.

ex) fact:user-m clr

### FACT:LAST-STA {DIS|SAF|FUL}

When you turn on the power supply, you can select the default state of output DC power.

- > DIS      When selected this mode, boot the power supply to original default value.
- > SAF      When you turn on the power supply, appears "OUTPUT OFF" display.  
            But if you press the "OUTPUT" key, recall the last state voltage/current value.
- > FUL      Recall the state before you turn off fully.

*ex) fact:last-sta saf    Set the safetymode.*

### FACT:LAST-STA?

Confirm the Last-state value.

- Return value    "DISABLE"
- "SAFETY"
- "FULLY"

*ex)fact:last-sta return value "SAFETY"*

### FACT:AUTO-CUR {DIS|ENA}

If the power supply doesn't receive any operation by using front-panel within a certain period of time, the power supply's cursor location go down to minimum changing unit automatically when you set the "AUTO CURSOR MV" mode is enable.

- > DIS      Disable "AUTO CURSOR MV" mode.
- > ENA      Enable "AUTO CURSOR MV" mode.

*ex) fact:auto-cur ena    Disable "AUTO CURSOR MV" mode.*

### FACT:AUTO-CUR?

Confirm the auto cursor value.

- Return value    "0"      *Disable state*
- "1"      *Enable state*

*ex)fact:auto-cur?    return value "1"*

### FACT:AUTO-LOC {DIS|ENA}

If the power supply doesn't receive any operation by using front-panel within a certain period of time, the power supply becomes the key lock state automatically when you set the AUTO KEY LOCK mode is enable.

- > DIS      Disable "AUTO KEY LOCK" mode.
- > ENA      Enable "AUTO KEY LOCK" mode.

*ex) fact:auto-loc ena    Set the auto lock function.*

### FACT:AUTO-LOC?

Confirm auto key lock value.

- Return value    "0"      *Disable state*
- "1"      *Enable state*

*ex)fact:auto-loc?    return value "1"*

### FACT:OVP {DIS|ENA}

Enable or disable the "Over Voltage Protection" function.

- > DIS      Disable "OVP USE" mode.
- > ENA      Enable "OVP USE" mode.

*ex) fact:ovp dis      Set the disable "OVP" function.*



### FACT:OVP?

Confirm OVP function value.

Return value    "0"    *Disable state*  
                  "1"    *Enable state*

ex)fact:ovp?        *return value "0"*

### FACT:OCP {DIS|ENA}

Enable or disable the "Over Current Protection" function

> DIS        *Disable "OCP USE" mode.*  
> ENA        *Enable "OCP USE" mode.*

ex) fact:ocp dis    *Set the disable "OCP" function.*

### FACT:OCP?

Confirm OCP function value.

Return value    "0"    *Disable state*  
                  "1"    *Enable state*

ex)fact:ocp?        *return value "0"*

### FACT:ADC {5|20|50|100|300|1300}

Be able to set the output voltage/current measuring speed and displaying speed.

> 5            *Measures voltage/current at every 5 times/1sec, measure very precise value.*  
> 20          *Measures voltage/current at every 20 times/1sec, measure very precise value.*  
> 50          *Measures voltage/current at every 50 times/1sec, measure precise value.*  
> 100         *Measures voltage/current at every 100 times/1sec, measure precise value.*  
> 300         *Measures voltage/current at every 300 times/1sec, measure value in fast.*  
> 1300        *Measures voltage/current at every 1300 times/1sec, measure value in fast.*

ex) fact:ADC 5        *Sampling speed is slow but you can read precise value.*

### FACT:ADC?

Confirm ADC Sampling speed.

Return value    "5Hz"    *5 times/1sec sampling time*  
                  "20Hz"   *20 times/1sec sampling time*  
                  "50Hz"   *50 times/1sec sampling time*  
                  "100Hz"  *100 times/1sec sampling time*  
                  "300Hz"  *300 times/1sec sampling time*  
                  "1.3KHz" *1300 times/1sec sampling time*

ex)fact:ADC?        *return value "5Hz"*

### FACT:LOAD-DEF

This function is to initialize to the factory mode's setting value.

*You can clear in User memory field excepted calibration data.*

ex)fact:load-def    *Initialize to the factory mode's setting value.*

## 6–8. System Commands

This is the command that is various control command of the power supply.

### SYST:BEEP

The event to beep sound of power supply

ex) syst:beep *Make beep sound.*

### SYST:ERR?

Confirm the power supply's error that occurred.

Error recording, save in volatile memory up to 10 event. If the error occurs more than 10, erase the first occurred error at first. If check the error, automatically erase the confirmed error and there are no error, you can receive +0 value, "No error" Message.

Return value – error number , "message"

ex) syst:err? *return value -222, "Out of data"*

### Note

1. About error, refer to "7. Error Messages".
2. If you send "CLS" command, every error is cleared. But in case of "\*RST" command, not cleared.

### SYST:VERS?

You can confirm the power supply's version.

Return "YYYY.Ver"

*YYYY – developed year.*

*Ver – Product version of development year.*

ex) syst:vers? *return value "2008.3"*

### OUTP {OFF|ON}

You can control the power supply's DC output state of ON or OFF.

> ON Output on.

> OFF Output off.

ex1) outp on *DC power output on*

ex2) outp off *DC power output off*

### OUTP?

Confirm the power supply's DC output ON or OFF state.

Return value " 0 " *Output off state.*

" 1 " *Output on state.*

ex) outp? *return value "1"*

### KEYL {OFF|ON}

This command is controlling the front panel's key/encoder knob locking or unlocking.

- > ON      Key locking.
- > OFF     Key unlocking.

ex1) keyl on          *Key locking.*  
ex2) keyl off         *Key unlocking.*

### KEYL?

Confirm controlling the front panel's key/encoder knob locking or unlocking state.

Return value " 0 " *Output off state.*  
              " 1 " *Output on state.*

ex) keyl?    *return value "1"*

### \*IDN?

This command is confirming the power supply's properties. You will receive 3 kinds properties.

Return value "ODA Technologies,PT-Series,1.3-1.3-1.2"  
              First,          Manufacturer.  
              Second,        Products model.  
              Third,         Products detailed version.  
                              First,                System controller Version  
                              Second,            Front panel Version  
                              Third,             SCPI protocol Version

ex) \*idn?    *return value "ODA Technologies,PT-Series,1.3-1.3-1.2"*

### \*SN?

Confirm the power supply serial number.

Return value "oda-00-0000-00000"

ex) \*SN?    *return value "oda-01-0923-00185"*

### \*SAV {1|2|3|4|5|6|7|8|10}

This command is saving the power supply's voltage, current, OVP, OCP Level value in the non-volatile memory of 1~10.

- > 1 ~ 10      Memory saving sector number.

ex) \*sav 2      *Save to number 2 memory sector.*

### \*RCL {1|2|3|4|5|6|7|8|10}

This command is recalling the power supply's saved data in the non-volatile memory  
You can select among 1 ~ 10 number.

- > 1 ~ 10      Memory sector.

ex) \*rcl 2      *Recall and apply the number 2 memory data to the power supply.*

**\*CLS**

Clear the all error event.

ex) \*CLS

**\*RST**

This command is initializing of the power supply. Following is initializing contents.

- > Output OFF
- > Voltage Limit 0V
- > Current Limit Maximum current value of the power supply.
- > OVP Maximum OVP value of the power supply.
- > OCP Maximum OCP value of the power supply.
- > UVL 0V
- > OVL Voltage Limit MAX value.
- > UCL 0A
- > OCL Current Limit MAX value.
- > Volt:Step Minumum value of setting
- > Curr:Step Minumum value of setting
- > Key Lock OFF
- > Factory Mode Keep the value of before reset
- > Trip상태 Clear if the OVP or OCP Tripped occurred automatically.

ex) \*RST *Initialize the power supply.*

## 7. Error Messages

About error explanation. You can confirm the error by using front panel's "ERROR I/O Local" key or PC remote interface.(Refer to "SYST:ERR?" command.)

+0, "No error"

No error state.

### 7-1. Operating Error

-10, "Invalid the DAC parameter"

In case of out of DAC memory section, it is different between setting value and real output value and at that time, you must remove the DUT.

It is caused from wrong calibration data. Please operate calibration one more.

Refer to "4. CALIBRATION".

### 7-2. Hardware Error

-200, "System interface error"

It appears when SCPI Module is out of order.

-201, "ADC operating failed"

It appears when circuit of ADC part is out of order.

-202, "Front panel operating failed"

It appears when front panel does not response.

-255, "Error not define"

It appears when unknown error occurs.

### 7-3. Remote Calibration Error

Refer to "4-6. Remote Interface Calibration."

-20, "Ignored min run under volt"

If you set the "max" command or value input of calibration without voltage "Min"

Procedure : Min → VALUE → MAX → VALUE

-21, "Ignored min save under volt"

If you set the "max" command without "Value" of voltage "Min" calibration operating.

Procedure : Min → VALUE → MAX → VALUE

-22, "Invalid min value use under volt"

After sent the command of voltage "Min" value and then you sent the value command without Max command calibration operating.

Procedure : Min → VALUE → MAX → VALUE

**-23, "En route to cal the curr"**

It appears when sended calibration command about voltage during current calibration.

**-24, "Over volt min parameter"**

It appears voltage Min value is over the power supply's voltage limit.

*Refer to "4-5. Using Front Panel Calibration."*

**-25, "Under volt max parameter"**

It appears voltage Max value is gotton out the power supply's voltage lowest limit value.

*Refer to "4-5. Using Front Panel Calibration."*

**-26, "Over volt max parameter"**

It appears voltage Max value is gotton out the power supply's voltage highest limit value.

*Refer to "4-5. Using Front Panel Calibration."*

**-27, "Ignored min run under curr"**

If you set the "max" command or value input of calibration without current "Min".

Procedure : Min → VALUE → MAX → VALUE

**-28, "Ignored min save under curr"**

If you set the "max" command without "Value" of current "Min" calibration operating.

Procedure : Min → VALUE → MAX → VALUE

**-29, "Invalid min value use under curr"**

After sent the command of current "Min" value and then you sent the value command without Max command calibration operating.

Procedure : Min → VALUE → MAX → VALUE

**-30, "En route to cal the curr"**

It appears when sended calibration command about current during voltage calibration.

**-31, "Over curr min parameter"**

It appears current Min value is over the power supply's current limit.

*Refer to "4-5. Using Front Panel Calibration."*

**-32, "Under curr max parameter"**

It appears currenr Max value is gotton out the power supply's current lowest limit value.

*Refer to "4-5. Using Front Panel Calibration."*

**-33, "Over curr max parameter"**

It appears current Max value is gotton out the power supply's current highest limit value.

*Refer to "4-5. Using Front Panel Calibration."*

**-34, "Not allowed command under cal"**

Under the remote calibration mode, you can not use another command.

## 7-4. Calibration Error

If you do calibration, the power supply also do calibration of readback.  
The following errors indicate failures that may occur during a calibration.

### -74, "ADC-V low limit over"

It appars when calibration of voltage ADC low section is out of range

### -75, "ADC-V high limit over"

It appars when calibration of voltage ADC high section is out of range.

### -76, "ADC-A low limit over"

It appars when calibration of current ADC low section is out of range.

### -77, "ADC-A high limit over"

It appars when calibration of current ADC high section is out of range.

## 7-5. Nonvolatile Memory Check Error.

and digit length.

If check the properties and occur the error, it appears the error.

### -80, "Memory limit volt error"

It means the error of setting available voltage value.

### -81, "Memory limit curr error"

It means the error of setting available current value.

### -82, "Memory max volt error"

It means the error of the power supply's maximum voltage value.

### -83, "Memory max curr error"

It means the error of the power supply's maximum current value.

### -84, "Memory volt decimal error"

It means the error of the power supply's point expression of voltage.

### -85, "Memory curr decimal error"

It means the error of the power supply's point expression of current.

### -86, "Memory volt length error"

It means the error of the power supply's digit length of voltage.

### -87, "Memory curr length error"

It means the error of the power supply's digit lengt of current.

### -88, "Not match volt length and limit"

It means the error of no match between the power supply's setting available voltage value and digit length.

### -89, "Not match curr length and limit"

It means the error of no match between the power supply's setting available current value and digit length.

## 7-6. Interface Commands Error

This chapter is for PC interface communication error.

### -120, "Suffix too long"

A suffix for a numeric parameter contained too long characters. Maximum memory buffer that you are able to send is 50 byte at only once.

### -121, "Invalid data"

A suffix was incorrectly specified for a numeric parameter. You may have misspelled the suffix.

*ex) volt 10\* You added V is added.  
You must revise to "volt 10".*

### -122, "Syntax error"

Invalid syntax was found in the command string. You may have inserted a blank space before or after a colon in the command header, or before a comma.

*ex) volt You skipped the numeric value.  
You must revise to "volt 10".*

### -123, "Invalid suffix"

A suffix was incorrectly specified for a numeric parameter. You may have misspelled the suffix.

*ex) volt 10\* You added "\*" after command  
You must revise to "volt 10".*

### -124, "Undefined header"

A command was received that is not valid for this power supply. You may have misspelled the command or it may not be a valid command. If you are using the short form of the command, remember that it may contain up to four letters.

*ex) volta 10 The power supply just receive "volt" or "voltage".  
You must revise to "volt 10".*

### -220, "No execution"

The power supply does not accept to execute.

*ex) Volt 20 Set the voltage to 20V.  
Volt:OVP 15 ; The error occurred when you set the OVP level lower  
than setting voltage value.*

### -221, "Setting conflict"

Indicates that a legal program data element was parsed but could not be executed due to the current device state.

*ex) POL N This is polarity change command, but could not be executed  
in current device.*

### -222, "Out of data"

A numeric parameter value is outside the valid range for the command.

*ex) volt 1000 Voltage setting value is too much big.  
You must revise to "volt 10".*

### -223, "Incorret error"

It appears when you send new query command again without receiving former query command execution from buffer.

*ex) \*idn? You sent the query command to the power supply and  
volt? immediately send again another new command.*



## 9. System

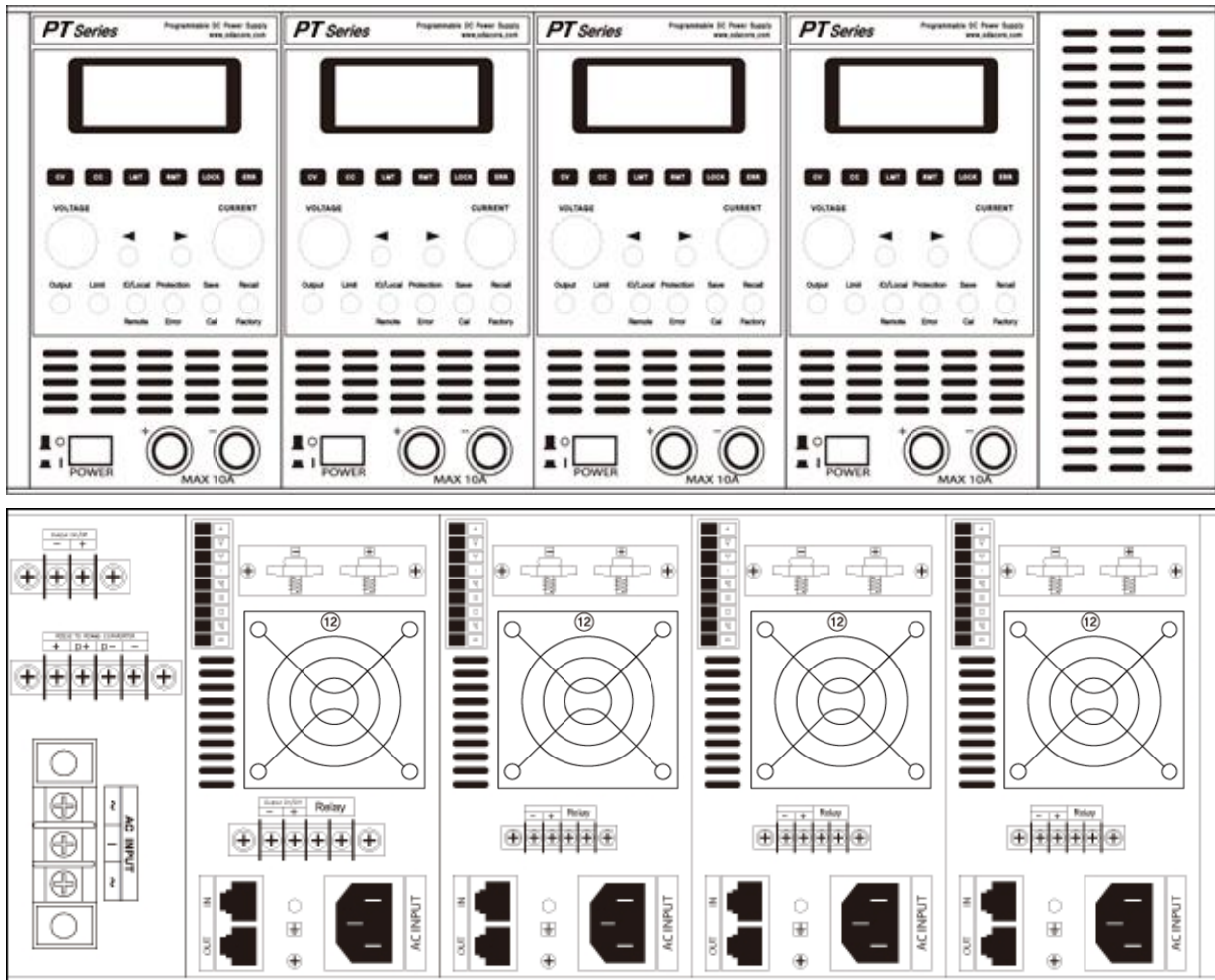

### Note

Service Center : 82-70-5032-2921~2  
 Home page : [www.odacore.com](http://www.odacore.com)

## 10. Cautions.

Non compliance with the warnings and/or the instructions for use may damage the instrument and/or its components or injure the operator. Keep following articles.

- Avoid the installation in severe cold or hot area.
- Do not use immediately after moved from cold area  
As liquefaction phenomenon, it gives damage to the power supply  
After 20~30min later, use the power supply.
- Do not place the liquor thing on the power supply  
The use of this instrument in a wet state could result in electrical shock or fire..
- Avoid vibration or severe impact.
- Make sufficient space at the sides and rear of the power supply for adequate air circulation.
- Do not place the heavy things on the power supply.
- Avoid the electric-magnetic field as motor and etc.
- Do not allow any foreign matter such as metal or inflammable substance to get into the instrument via the air holes . The penetration of any foreign matter from the ventilation holes could result in fire . electrical shock ,or power failure.
- Avoid hot instrument such as iron nearby the power supply.
- Do not place the front panel to downside.  
It will occur to break encoder knob and etc.
- Do not connect other kinds power sources to this power supply output bus bar.

**ODA TECHNOLOGIES CO.,LTD.**

62, Bupyeong-daero 329beon-gil,  
Bupyeong-gu Incheon city, 403-858, Korea  
TEL. +82-2-1800-8644  
FAX. +82-32-715-5456

---

[www.odacore.com](http://www.odacore.com)  
[sales2@odacore.com](mailto:sales2@odacore.com)