

HIGH FREQUENCY HIGH VOLTAGE PROBE

高壓測試棒

INSTRUCTION MANUAL

使用說明書

For model:

***HVP-10R / HVP-18HF /
HVP-28HF / HVP-39pro***



CE

TABLE OF CONTENTS

1. SPECIFICATIONS	1
2. SAFETY PRECAUTIONS	2
3. OPERATION	2
4. COMPENSATION ADJUSTMENT	3
4-1 HVP-10R	3
4-2 HVP-18HF/ HVP-28HF/ HVP-39pro	4
5. WARNING	6
6. CLEANING	6
7. VOLTAGE DERATING CURVE	7
8. ACCESSORIES	9

目錄

1. 規格	11
2. 簡述與安全須知	12
3. 操作說明	12
4. 匹配電容調整	13
4-1 HVP-10R	13
4-2 HVP-18HF/ HVP-28HF/ HVP-39pro	14
5. 注意事項	16
6. 清潔	16
7. 電壓測試臨界曲線	17
8. 附件	19

HIGH FREQUENCY HIGH VOLTAGE PROBE

INSTRUCTION MANUAL

***HVP-10R / HVP-18HF /
HVP-28HF / HVP-39pro****

{ note* }

HVP-39pro:

Caution!

When measuring voltage source is over DC 30KV or AC 20KV, this probe is not suitable for long time using. High voltage source will have sparks in the air and cause high voltage source regular circuit does not have time to respond. This will have pulse high voltage and which will cause this probe over rating and damage the product.

1. SPECIFICATIONS

Model	HVP-10R	HVP-18HF	HVP-28HF	HVP-39pro
Division Ratio	100:1	1000:1	1000:1	1000:1
Read Out	○	—	—	—
Input Resistance	100M Ω	200M Ω	500M Ω	900M Ω
Input Capacitor	2.0 PF	1.5 PF	1.7 PF	2.0 PF
Max. DC+AC peak	10KV CAT II	18KV CAT II	28KV CAT II	39KV CAT II
Max. AC RMS.	7KV CAT II	12KV CAT II	20KV CAT II	27KV CAT II
Pulse Voltage	< 7KVp-p	< 12KVp-p	< 20KVp-p	< 27KVp-p
Max. Loading Current	100uA	90uA	56uA	45uA
Band Width	DC~120MHz	DC~100MHz	DC~75MHz	DC~50MHz
Rise Time	3.0 nS	3.5 nS	5.3 nS	7 nS
Signal / Noise	>60dB at 1KHz ; >50dB at 1MHz			
DCV Accuracy	$\leq 3\%$ Full Range			$\leq 3\%$ (0~35KV)
ACV Accuracy	$\leq 3\%$ at 1 KHz			
Temp. Coefficient	≤ 200 PPM/ $^{\circ}$ C			
Compensation Range	10PF~35PF			
Safety	Meets EN61010-031 CAT II			
Cable Length	2M \pm 0.2M			
Operation Temp.	-10~55 $^{\circ}$ C			
Humidity	85% RH or less(at 35 $^{\circ}$ C)			
Storage Temp.	-20~70 $^{\circ}$ C			
Color: Handel/Body	Black/Milk Gray	Black/Yellow	Black/Dark Gray	Black/Red
Weight / Volume	460g /80(W) x 80(H) X 320(L) mm			

2. SAFETY PRECAUTIONS

This high voltage probe only for the person who are trained, experienced, or otherwise qualified to recognize hazardous situations and who trained in the safety precautions that necessary to avoid possible injury when using such a device.

Do not work alone when working with high voltage circuits.

For your own safety, inspect the probes for cracks and frayed or broken leads before each use. If defects are noted, DO NOT USE the probe.

Hands, shoes, floor and work bench must be dry. Avoid making measurements under humid, damp or other environmental conditions that might affect the safety of the measurement situation.

If possible, always turn the high voltage source off before connection or disconnection the probe.

The probe body should be kept clean and free of any conductive contamination.

The probe is for indoor use only.

Note:

Please hold the handle when in use. Do not pull the wire.

Replacement or refund is not possible if the co-axis wire is broken caused by the pulling of wire.

3. OPERATION

Connect the divider probe common lead(alligator clip) to a good earth ground or reliable ground.

Connect the BNC connector to the BNC input of your oscilloscope.

Select the desired range of your oscilloscope. Whenever possible, turn the high voltage source off before making any connections.

4.COMPENSATION ADJUSTMENT

4-1 HVP-10R:

The following adjustment is required whenever the probe is transferred from one oscilloscope or input channel to another.

Connect the probe to the oscilloscope, apply a 1KHz square wave to the probe tip and adjust the oscilloscope controls to display a few cycles of the waveform. Adjust the trimmer located in the BNC plug for a flat topped square wave.

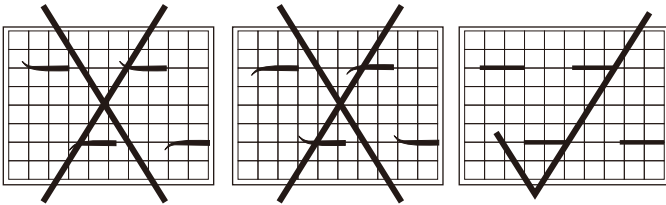
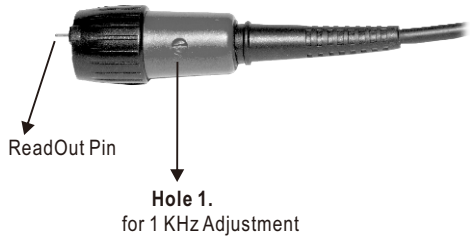

Illustration of 1KHz square wave adjustment.

The HVP-10R is compatible with readout function oscilloscopes that automatically detect and display the attenuation factor of the probe.



CAUTION:

When the measuring frequency was 40MHz up, you must change to the shortest earth lead and connected to the Alligator Clip(BP-276N-D) to obtained a best earth and the best frequency response.

4-2 HVP-18HF/ HVP-28HF/ HVP-39pro:

The following adjustment is required whenever the probe is transferred from one oscilloscope or input channel to another.

Connect the probe to the oscilloscope, apply a 200Hz square wave to the probe tip and adjust the oscilloscope controls to display a few cycles of the waveform. Adjust the trimmer located in the BNC plug for a flat topped square wave.

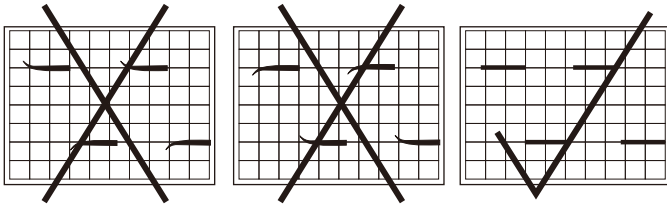
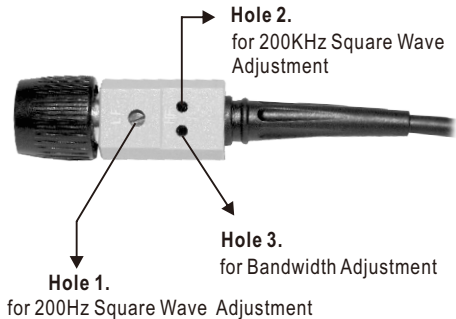

Illustration of 200Hz square wave adjustment.

Adjust the frequency response of the probe to match your oscilloscope by the adjust bar attached only.



CAUTION!

1. The HVP-18HF/ HVP-28HF/ HVP-39pro adjust Hole 2 and Hole 3 are for the qualified engineer only.
2. The HVP-10R adjusts Hole 1 only.

3. Before adjusting Hole 2 and hole 3, please move off the plastic cover at first.
4. Use the adjust bar attached only.
5. When the measuring frequency was 40MHz up, or to adjust Bandwidth(Hole 3.), you must changed to the shortest earth lead and connected to the Alligator Clip(BP-276N-D) to obtained a best earth and thee best frequency response.

BP-276N-D
(For 40MHz up
Measuring Frequency)



5. WARNING

Do not attempt to take measurements from the sources when the chassis or return lead is not ground.

The ground connection is critical to the safety operation of the probe. Failure to make this connection may result in personal injury or damage to the probe or voltmeter. This connection must be made before the probe tip comes into contact with the high voltage and must not be removed until after the probe tip has been removed.

Do not connect the ground clip to the high voltage source or the probe tip to the ground for any reason.

BEFORE turning the high voltage on, make sure that no part of your body is in contact with the device.

Remembering that the voltage being measured is 1000 times(HVP-10R is 100 times) greater than the voltmeter reading.

Disconnect the probe tip from the high voltage source **BEFORE** removing the ground clip lead.



SPECIAL WARNING:

Please be sure the ground cable is connected securely. High voltage may damage oscilloscopes if ground cable is not connected properly.

6. CLEANING

Clean only the exterior probe body and cables. Use a soft cotton cloth lightly moistened with a mild solution of detergent and water. Do not allow any portion of the probe to submerged at any time.

Dry the probe thoroughly before attempting to make voltage measurement.

Do not subject the probe to solvents or solvent fumes as these can cause deterioration of the probe body and cables.

7.VOLTAGE DERATING CURVE

7-1 HVP-10R (10KV:1KHz /5KV:10KHz /1KV:100KHz /100V:100MHz)

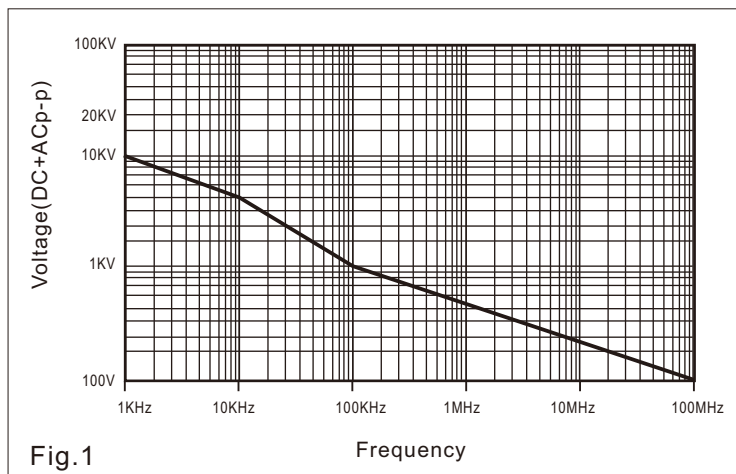

7-2 HVP-18HF (18KV:1KHz /9KV:10KHz /2KV:100KHz /150V:100MHz)

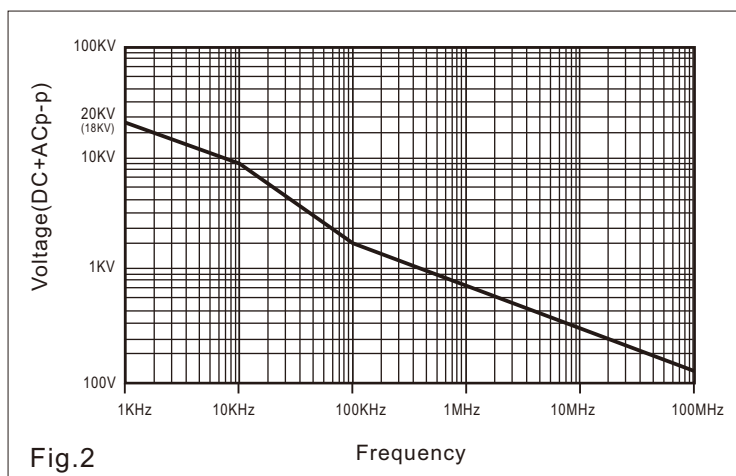

7-3 HVP-28HF (28KV:1KHz /14KV:10KHz /3KV:100KHz /200V:100MHz)

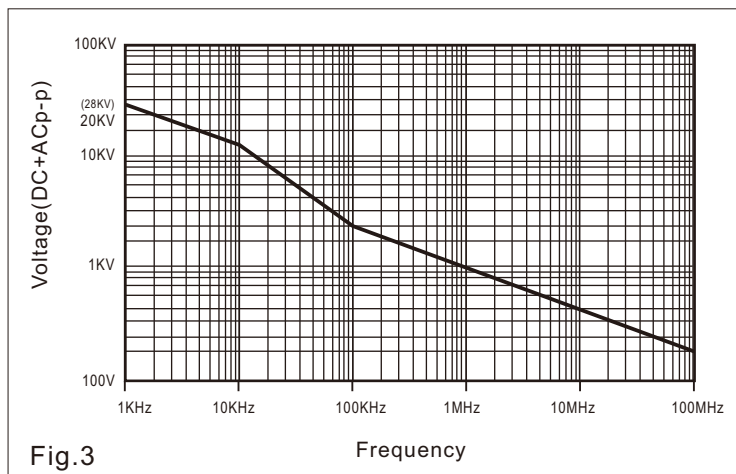

7-4 HVP-39pro (39KV:1KHz /20KV:10KHz /5KV:100Hz /300V:100MHz)

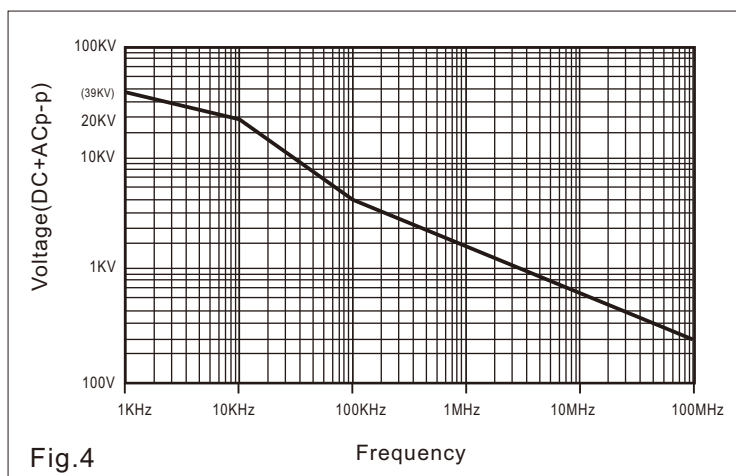

8.ACCESSORIES



Test CRT
for H.V.

ROD-ADJ-002
Adjust bar



PX-503
Carry Box



PL-10(Optional)
To Connect With
Digital DMM.

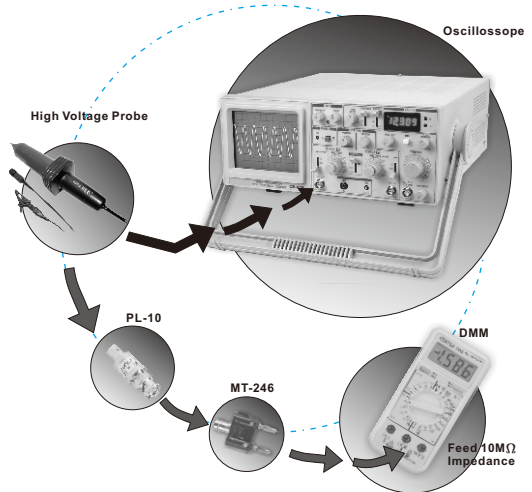

高壓測試棒使用說明書

***HVP-10R / HVP-18HF /
HVP-28HF / HVP-39pro****

(註*)

HVP-39pro:

注意! 當測量電壓源超過DC 30KV, 或AC 20KV以上時, 本產品不適用於長時間使用。因為高電壓的測量來源將會對空氣中任意放電, 造成高壓電壓源的穩壓電路來不及反應, 瞬間將會有脈衝高壓發生, 脈衝高壓很有可能超過本產品的額定值, 將會造成本產品的嚴重損壞。

1. 規格

型號	HVP-10R	HVP-18HF	HVP-28HF	HVP-39pro
衰減比例	100:1	1000:1	1000:1	1000:1
讀出功能	○	—	—	—
輸入阻抗	100MΩ	200MΩ	500MΩ	900MΩ
輸入電容	2.0 PF	1.5 PF	1.7 PF	2.0 PF
最大輸入:DC+AC peak	10KV CAT II	18KV CAT II	28KV CAT II	39KV CAT II
最大輸入:AC RMS.	7KV CAT II	12KV CAT II	20KV CAT II	27KV CAT II
脈波電壓	< 7KVp-p	< 12KVp-p	< 20KVp-p	< 27KVp-p
最大負載電流	100uA	90uA	56uA	45uA
頻寬	DC~120MHz	DC~100MHz	DC~75MHz	DC~50MHz
上升時間	3.0 nS	3.5 nS	5.3 nS	7 nS
噪信比	>60dB at 1KHz ; >50dB at 1MHz			
直流信號誤差值	≤3% 全部範圍檔			≤3% (0~35KV)
交流信號誤差值	≤3% 在 1 KHz			
溫度係數	≤200 PPM/°C			
匹配電容調整範圍	10PF~35PF			
安規檢驗	符合 EN61010-031 CAT II 規範			
測試線長度	2M±0.2M			
操作溫度溼度	-10~55 °C / 85% RH 或更低(at 35°C)			
儲存溫度	-20~70 °C			
顏色:握把/本體	黑/淺灰色	黑/黃色	黑/鐵灰色	黑/紅色
重量/材積	460g /80(寬) x 80(高) X 320(長) mm			

2. 簡述與安全須知

感謝您購買HVP系列高壓測試棒；高壓測試棒是為防止測試人員在做高壓測量工作時，受到意外電擊，而設計的一種產品。在使用高壓測試棒以前，操作者必須先閱讀安全規則並且充分理解後才能使用高壓測試棒。

此外，只有接受過高壓測試培養訓練、有過高壓測試經驗或能辨別高壓危險情況的測試人員才能使用這種高壓測試棒。在使用高壓測試棒的時候，受過安全警示知識培養訓練的測試人員可以防止在操作過程中出現意外的傷害。

請不要一個人在超過人體安全範圍的電壓下工作。

為了自身的安全，每次使用高壓測試棒以前，要認真檢查所使用高壓棒表面磨損和高壓棒測試端破損情況，如果有磨損、破損問題出現，千萬不要使用此測試棒。

雙手、鞋、地板和工作椅一定要保持乾燥，並避免在潮濕、發霉或者其他影響安全測量的環境下進行測量工作。在連接或者拆下測試棒以前，需要把高壓電源關閉。

高壓測試棒要保持乾淨，污垢等污染物能在測試棒表面提供傳導途徑，一定要使用無安全隱憂的測試棒。

注意:

使用時請握住把手，不要拉扯電線，如拉扯電線造成鉸線斷掉不予更換或退貨。

3. 操作說明

連接測試棒衰減端的地線（鱷魚夾）到好的接地點或可靠的接地測試端上。

連接BNC連接頭到示波器的BNC輸入端口。

選擇示波器要求的量程範圍。

〔注意〕 無論如何，請務必在連接測試以前把高壓電源關閉。

4. 匹配電容調整

4-1 HVP-10R:

每當測試棒更換示波器或更換通道時,請先進行下列調整步驟:

連接測試棒至示波器,輸入1KHz方波至測試棒測試端,然後調整示波器控制項進而顯示一些波形,並針對方波波型上升型態調整位於BNC接頭的可變電容器。

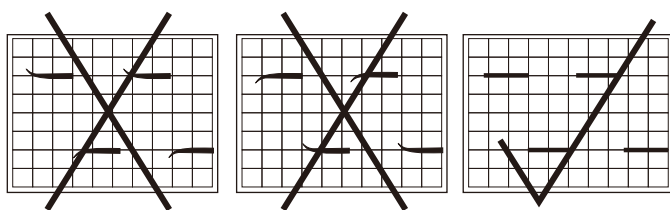

正確調整1KHz 方波的示意圖

HVP-10R 是有讀出功能的; 當接在有讀出功能的示波器並正確的選擇衰減比例, 就能自動讀出原測試值電壓。

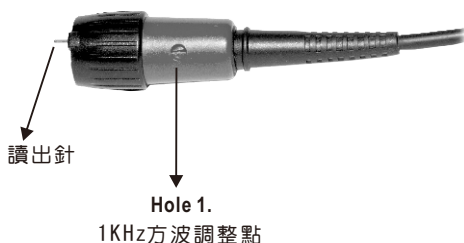

警告:

- (1)當測量頻率大於40MHz時, 必須將長地線更換為鱷魚夾 (BP-276N-D) 以便取得最小的接地電阻值和更高的頻率響應。
- (2)調整方波時請指定使用本公司的附件調棒。
- (3)1KHz方波請使用函數信號產生器, 輸出20Vp-p, 或是選用本公司出品的FG-32/52/72/102等機種。

4-2 HVP-18HF/ HVP-28HF/ HVP-39pro:

連接測試棒至示波器，輸入200Hz方波至測試棒測試端，然後調整示波器控制項進而顯示一些波形，並針對方波波型上升型態調整位於BNC接頭的可變電容器。

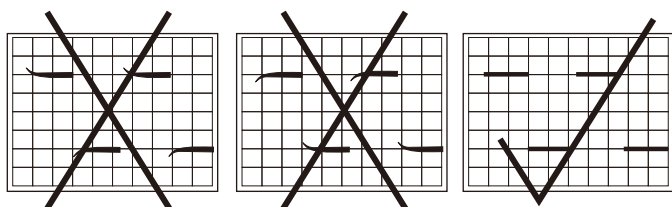

正確調整200Hz方波的示意圖

更換示波器時請依指示調整Hole 1.即可。

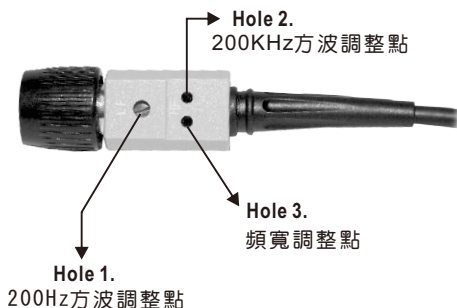

警告:

- (1) 200Hz方波請使用函數信號產生器，輸出20Vp-p，或是選用本公司出品的FG-32/52/72/102等機種。
- (2) 非專業人員請勿調整Hole 2, Hole 3 調整點。
- (3) 本產品出場時已經對Hole 2, Hole 3調整過，請安心操作使用。
- (4) 調整時請使用本公司附的指定調棒。

(5)當待測高壓的頻率超過40MHz時，爲了取得更好的頻率響應與最佳的接地，請將長地線更換爲鱷魚夾(BP-276N-D)。

BP-276N-D

(當量測 40MHz 以上的高頻電壓時請改用此鱷魚夾直接接地，可以獲得最佳的頻率響應)



5. 注意事項

請勿試圖把測試設備的接地線從地面接線柱上移開。

接地連接是測試棒安全操作的一個關鍵點。當高壓測量的時候，如果沒有這種連接將可能導致人身傷害或者對連結的示波器、測試棒產生損害。在測試棒測試端測試連接高壓前，一定要先連接好地線，並且地線連接不能輕易挪開，直到高壓測試端遠離高壓源。

絕對不能把接地線與高壓電源連接或者把測試棒測試端接地。

打開高壓源以前要保證身體的任何部位都沒有和測試設備接觸。

測量電壓時，請牢記被測電壓是實際讀數的1000倍。

在移走接地夾以前一定要把測試棒高壓測試端從高壓源上斷開。

 特別注意!

接地線若接地不確實，高壓電有可能擊毀示波器，請務必接受。

6. 清潔

只需清洗測試棒外部和電纜即可，用軟棉布輕輕蘸點酒精和水清洗。不可以把測試棒的任何部分浸泡在液體裡。

在做電壓測量以前要使測試棒全部乾燥。

不要把測試棒放進有腐蝕性溶液或者有腐蝕性煙氣裡，因為這樣將可能引起測試棒和電纜的破損。

7. 電壓測試臨界曲線

7-1 HVP-10R (10KV:1KHz / 5KV:10KHz / 1KV:100KHz / 100V:100MHz)

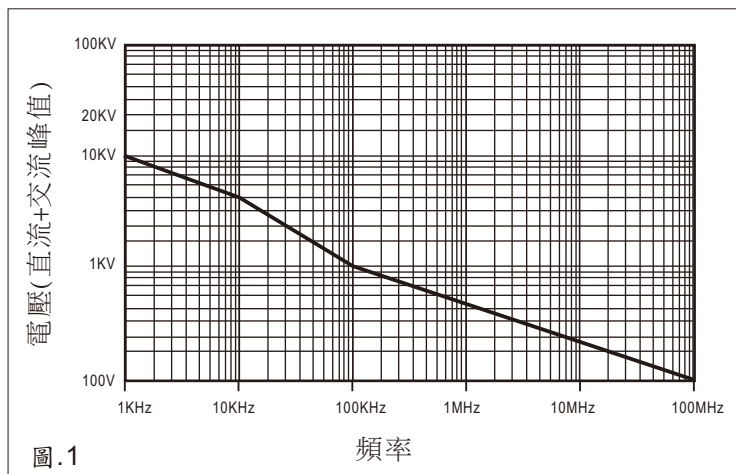

7-2 HVP-18HF (18KV:1KHz / 9KV:10KHz / 2KV:100KHz / 150V:100MHz)

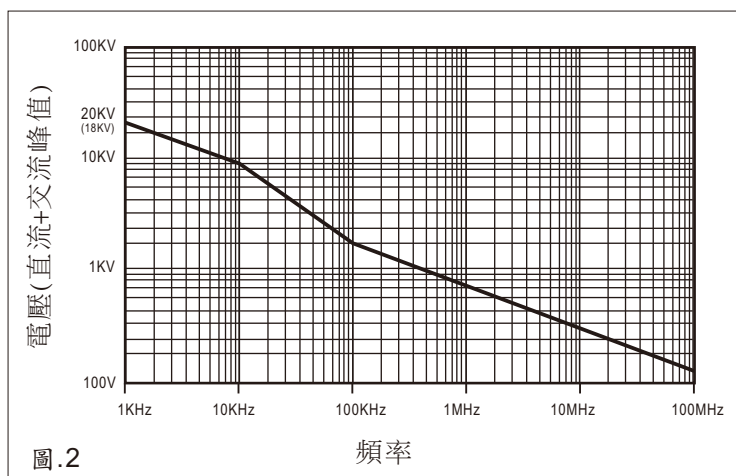

7-3 HVP-28HF (28KV:1KHz /14KV:10KHz /3KV:100KHz /200V:100MHz)

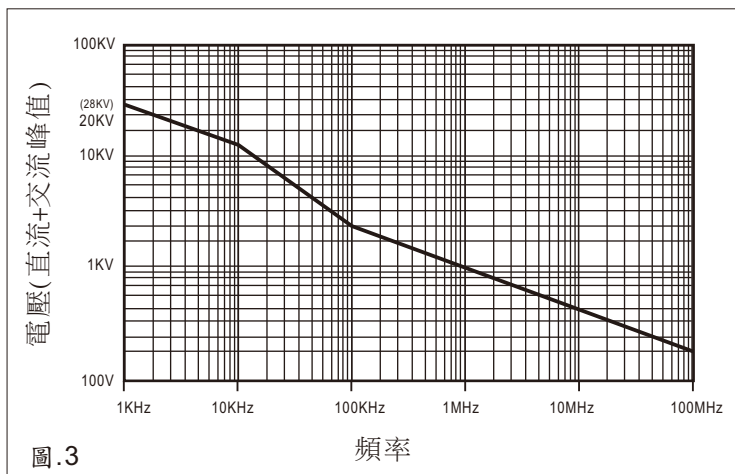

7-4 HVP-39pro (39KV:1KHz /20KV:10KHz /5KV:100Hz /300V:100MHz)

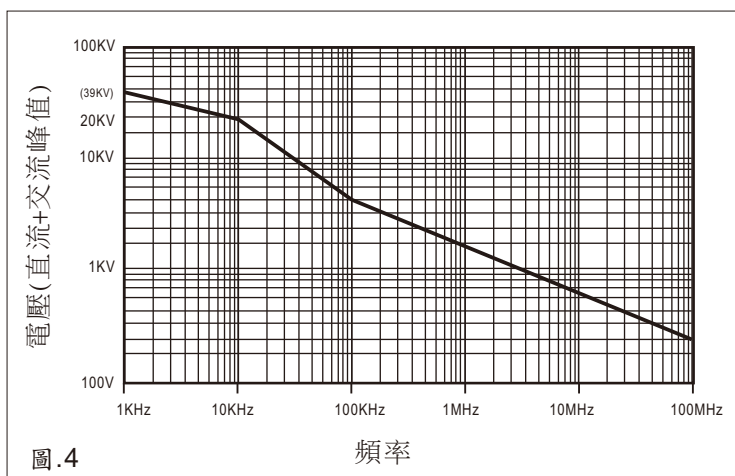

8. 附件

測試影像管用附件



ROD-ADJ-002
本機專用調整棒



PX-503 攜帶箱



PL-10(Option)
(選購)
連接數字電錶專用

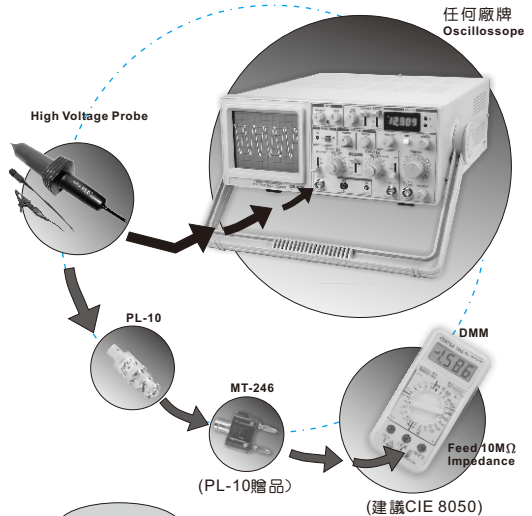

TINSE0062S4 Rev.12
Made In Taiwan