



PicoScope® 9400 Series

Sampler-extended real-time oscilloscope

User's guide

Contents

1 Welcome	6
2 Introduction	8
1 Overview	8
2 Minimum PC requirements	8
3 Safety information	9
1 Symbols	9
2 Maximum terminal ratings	10
3 Grounding	11
4 External connections	11
5 Environment	12
6 Care of the product	12
3 Product information	13
1 What do I get?	13
2 Connections	14
4 How to use your oscilloscope	16
1 Acquiring, triggering and displaying waveforms	16
2 Measuring waveforms	20
1 Graticule measurements	20
2 Marker measurements	21
3 Automated measurements	22
4 Histogram measurement	23
5 Eye diagram measurements	25
6 Mask test	26
3 Waveform math	28
4 Connecting using LAN or USB interfaces (not 9402 models)	29
1 Select current interface	30
2 Configure common LAN Settings	31
3 Configure the oscilloscope's LAN settings	32
4 Configure other PicoSample 4 software LAN settings	32
5 Specifications and characteristics	35
1 Vertical	35
2 Horizontal	38
3 Acquisition	39
4 Trigger	41
1 Internal trigger	41
2 External direct trigger	42
3 External prescaled trigger	43
5 Display	44
6 Save/Recall	46

7 Marker	47
8 Measure	47
9 Mathematics	48
10 Histogram	49
11 Eye diagram	50
12 Mask test	50
13 Inputs/outputs	54
14 Power requirement	56
15 PC connection	56
16 Physical characteristics	57
17 Environmental conditions	57
6 PicoSample 4 software	58
1 Demo mode	58
2 Display area	59
3 Drag and zoom	59
4 Main menu	59
1 File	60
2 Edit	65
3 View	65
4 Setup	69
5 Measurements	70
6 Analysis	71
7 System	72
8 Utility	74
9 Help	75
5 Measurement area	76
6 Permanent controls	78
7 Pop-up keypad	79
8 Side menu	80
9 Status area	80
10 System controls	80
1 Clear	81
2 Run, Stop and Single	81
3 Autoscale	82
4 Default setup	82
5 Undo, Redo	83
6 Copy	83
7 Help	83
11 Startup	85
12 Toolbar	85
7 Menu	86
1 Channels Menu	86

1 Channel Setup	88
2 Zoom	97
2 Acquire Menu	98
1 Time Base	99
2 Acquisition	104
3 Zoom	111
3 Display Menu	112
1 Style	113
2 Screen	119
3 View	122
4 Color	123
5 Color Palette	125
4 Eye Diagram Menu	127
1 Parameter	129
2 Definition	155
5 Histogram Menu	160
1 Setup	163
2 Window	166
3 Scale	170
6 Marker Menu	172
1 Type	174
2 M1 Position and M2 Position	175
3 M1 Source and M2 Source	176
4 Motion	177
5 Reference On	177
6 Set Reference	177
7 Mask Test Menu	178
1 Compare with	178
2 Test	179
3 Create Mask	179
4 Run Until	202
5 # of Failed Wfms, # of Failed Smpls, # of Waveforms and # of Samples	203
6 Select Action	203
7 Erase Mask	203
8 Recall User Mask	204
9 Save User Mask	204
8 Mathematics Menu	205
1 Function	207
2 Scaling	226
3 Zoom	228
9 Measure Menu	229
1 Parameter	233
2 X Parameters...	236

3 Y Parameters...	241
4 Trace-to-trace Measurements	246
5 Counter	249
6 View Define Parameters	249
7 Clear All Measurements	249
8 Definition	250
10 Save/Recall menu	258
1 Waveform Memory	259
2 Disk	260
3 Setup	265
4 Zoom	270
11 Trigger Menu	271
1 Holdoff Mode	272
2 Holdoff, Min Holdoff, Max Holdoff	273
3 Mode	273
4 Settings	273
5 Style	274
6 Source	275
7 Level	275
8 Slope	276
9 Sensitivity	276
10 Hysteresis	276
12 Zoom Menu	277
1 Zoom Select	277
2 Main / Zoom	278
3 Zoom Area	278
4 Horizontal Factor	278
5 Horizontal Position	278
6 Vertical Zoom Source	279
7 Vertical Factor	279
8 Vertical Position	279
Index	280

1 Welcome

Thank you for buying a Pico Technology product!

The PicoScope 9400 Series Oscilloscopes from Pico Technology are wide-bandwidth, compact units designed to replace traditional mid- and wide-range benchtop digital storage oscilloscopes costing many times the price.

Model	Channels	Bandwidth
PicoScope 9404-16	4	16 GHz
PicoScope 9404-05	4	5 GHz
PicoScope 9402-16	2	16 GHz
PicoScope 9402-05	2	5 GHz



PicoScope 9404-16 (top)
PicoScope 9402-16 (bottom)

Here are some of the benefits provided by your new PicoScope 9400 Series Oscilloscope:

- **Portability.** Take the unit with you and plug it into any Windows PC.
- **Performance**
 - Two or four electrical channels with user-selectable bandwidth up to 5 GHz or 16 GHz
 - Vertical scale 10 mV/div to 250 mV/div with DC Gain accuracy better than $\pm 2\%$.
 - 500 MS/s per channel maximum real-time sampling rate with 12-bit resolution.
 - 2.5 TS/s (PicoScope 9404-16 or PicoScope 9402-16) and 1 TS/s (PicoScope 9404-05 or PicoScope 9402-05) maximum equivalent time sampling rate (0.4 ps and 1 ps shortest sampling interval respectively).
 - From 20 ps/div (PicoScope 9404-16 or PicoScope 9402-16) or 50 ps/div (PicoScope 9404-05 or PicoScope 9402-05) to 1000 s/div timebase scale with real time, random equivalent time and roll sampling modes.
 - DC to 2.5 GHz direct trigger, up to 5 GHz divided trigger from any input channel or external direct trigger input.
 - 6.5 Mb/s to 8 Gb/s clock recovery trigger (PicoScope 9404-16 or PicoScope 9402-16), and 6.5 Mb/s to 5 Gb/s clock recovery trigger (PicoScope 9404-05 or PicoScope 9402-05).
 - Up to 16 GHz external prescaled trigger (PicoScope 9404-16 or PicoScope 9402-16).
 - RMS jitter less than 2 ps.
- **Connectivity**
 - USB 2.0 (HS)
 - LAN (PicoScope 9404-16 or PicoScope 9404-05)
- **Programmability**
 - ActiveX
- **Powerful built-in measurement capabilities.** High-resolution cursors and automatic Pulse, NRZ and RZ eye pattern measurements with statistics, histograms, automated mask test with predefined standard and custom masks, waveform processing.
- **Applications.** Telecom Service and Manufacturing, Digital System Design, Semiconductor Characterization and Testing, High-Speed digital (pulse) measurements.
- **Flexibility.** Use it as a digital storage oscilloscope, spectrum analyzer or communications signal analyzer.

- **Long-term support.** Software upgrades are available to download from our [website](#). You can also call our technical specialists for support. You can continue to use both of these services free of charge for the lifetime of the product.
- **Value for money.** You don't have to pay twice for all the features that you already have in your PC, as the PicoScope 9400 Series oscilloscope contains only the special hardware you need and not the computer.
- **Convenience.** The software makes full use of the large display, storage, user interface and networking built in to your PC.

2 Introduction

2.1 Overview

The **PicoScope 9400 Series** PC Sampler Extended Oscilloscopes are a wide-bandwidth digital storage oscilloscope for use with personal computers. They are fully USB 2.0 and 3.0 compatible. You can also communicate with the four-channel (9404) models over their built-in LAN interface.

The PicoScope 9400 Series oscilloscopes can be used as digital storage oscilloscopes, spectrum analyzers or communications signal analyzers.

For basic instructions on installing and using your oscilloscope, please refer to [How to use your oscilloscope](#) or the printed **Quick Start Guide** supplied with your instrument.

2.2 Minimum PC requirements

For the oscilloscope to operate effectively it must be connected to a computer with these minimum requirements:

Processor, Memory	As required by operating system
Disk space	Software occupies about 50 MB
Operating system	Windows 7, Windows 8 or Windows 10. 32-bit and 64-bit versions.
Ports	USB 2.0 (high speed). Also compatible with USB 3.0.

2.3 Safety information

To prevent possible electrical shock, fire, personal injury, or damage to the product, carefully read this safety information before attempting to install or use the product. In addition, follow all generally accepted safety practices and procedures for working with and near electricity.

The product has been designed and tested in accordance with the European standard publication EN 61010-1:2010+A1:2019 (Safety Requirements for Electrical Equipment for Measurement, Control and Laboratory Use) and EN 61010-2-030:2010 (Requirements for Testing and Measuring Circuits). The product left the factory in a safe condition.

The following safety descriptions are found throughout this guide:







A **WARNING** identifies conditions or practices that could result in injury or death.

A **CAUTION** identifies conditions or practices that could result in damage to the product or equipment to which it is connected.

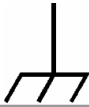
Each of these safety instructions applies to all the PicoScope 9400 Series oscilloscopes covered by this User's Guide, unless otherwise specified.

2.3.1 Symbols

These safety and electrical symbols may appear on the product or in this guide.

Symbol	Description
	Chassis terminal
	Earth (ground) terminal
	USB
	Possibility of electric shock
	Caution Appearance on the product indicates a need to read these safety and operation instructions.
	Do not dispose of this product as unsorted municipal waste



WARNING

This product and accessories are for professional use by trained and qualified technicians only. To prevent injury or death use the product only as instructed and use only accessories that have been supplied or recommended. Protection provided by the products may be impaired if used in a manner not specified by the manufacturer.

2.3.2 Maximum terminal ratings

Observe all terminal ratings and warnings marked on the product.

The table below and/or markings on the product indicate the full-scale measurement range and overvoltage protection range. The full-scale measurement ranges are the maximum voltages that can be accurately measured by the instrument and the overvoltage protection ranges are the maximum voltages that may be applied without risk of personal injury or damage to the instrument.



WARNING

To prevent electric shock, do not attempt to connect voltages outside the overvoltage protection range.

Input/output	Overvoltage protection range	Full-scale measurement range
Channels CH1 to CH4	± 1.4 V (DC + peak AC)	± 800 mV
CAL output	± 2 V (DC + peak AC)	–
DIRECT trigger input PicoScope 9402 only:	± 3 V (DC + peak AC)	± 1 V
PRESCALE trigger input PicoScope 9404-16: PicoScope 9402-16:	± 2 V (DC + peak AC) 3 V pk-pk max.	2 V p-p 2 V p-p
RECOVERED CLK output	± 2 V (DC + peak AC)	–
RECOVERED DATA output	± 2 V (DC + peak AC)	–
TRIGGER output	± 2 V (DC + peak AC)	–



WARNING

Signals exceeding the voltage limits in the table below are defined as "hazardous live" by EN 61010. To prevent electric shock, take all necessary safety precautions when working on equipment where hazardous live voltages may be present.

Signal voltage limits of EN 61010		
± 60 V DC	33 V AC RMS	± 42.4 V pk max.



WARNING

To prevent injury or death, do not connect the oscilloscope directly to the mains (line power).



CAUTION

To avoid causing permanent damage to the PicoScope and other connected equipment, do not exceed the overvoltage protection range on any terminal.

2.3.3 Grounding

WARNING

The PicoScope's ground connection through the USB cable is for measurement purposes only. The PicoScope does not have a protective safety ground.

WARNING

Never connect the ground input (chassis) to any electrical power source. To prevent personal injury or death, use a voltmeter to check that there is no significant AC or DC voltage between the oscilloscope ground and the point to which you intend to connect it.

CAUTION

To avoid causing permanent damage to the PicoScope, the attached computer, and other equipment, do not apply a voltage to the ground input.

CAUTION

To prevent measurement errors caused by poor grounding, always use the high-quality USB cable supplied with the oscilloscope.

2.3.4 External connections

WARNING

To prevent injury or death, only use the power cord and Pico approved adaptor supplied with the product. These are approved for the voltage and plug configuration in your country.

Ext DC power supply			
Voltage (V)	Voltage	Current (no accessories)	Current (with accessories)
PicoScope 9404-05	12 V DC \pm 5%	2.6 A max	3.3 A max.
PicoScope 9404-16		2.7 A max	3.3 A max.
PicoScope 9402-16 and PicoScope 9402-05		1.8 A max	N/A

CAUTION

Take care to avoid mechanical stress or tight bend radii for all connected leads, including all coaxial leads, optical fiber and connectors. Mishandling will cause deformation of sidewalls, and will degrade performance and measurement accuracy.

2.3.5 Environment



WARNING

To prevent injury or death, do not use in wet or damp conditions, or near explosive gas or vapor.



CAUTION

To prevent damage, always use and store your PicoScope in appropriate environments.

This product is for indoor or outdoor use, in dry locations only. The products external mains power supply (if required) is for indoor use only.

Temperature, operating	+5 °C to +40 °C
Temperature, storage	-20 °C to +50 °C
Temperature, for quoted accuracy	+15 °C to +25 °C
Humidity, operating	Up to 85 %RH (non-condensing) at +25 °C
Humidity, storage	Up to 95 %RH (non-condensing)
Altitude	Up to 2000 m
Pollution degree	2

2.3.6 Care of the product

The product contains no user-serviceable parts. Repair, servicing and adjustment require specialized test equipment and must only be performed by Pico Technology or an approved service provider. There may be a charge for these services unless covered by the Pico five-year warranty.

Inspect the instrument and all probes, connectors, cables and accessories before use for signs of damage.



WARNING

To prevent injury or death, do not use the product if it appears to be damaged in any way, and stop use immediately if you are concerned by any abnormal operations.

To prevent electric shock do not tamper with or disassemble the PicoScope, case parts, connectors or accessories.

When cleaning the PicoScope, use a soft cloth and a solution of mild soap or detergent in water. To prevent electric shock, do not allow water to enter the casing, as this will compromise the electronics or insulation inside.



CAUTION

Do not block the air vents at the back or front of the instrument as overheating will damage the oscilloscope.

Do not insert any objects through the air vents as internal interference will cause damage to the oscilloscope.

To prevent dirt ingress, fit dust caps to all unmated connectors, and remove them only during connection.

3 Product information

3.1 What do I get?

The PicoScope 9400 Series oscilloscope kits contain:

- PicoScope 9400 Series Sampler Extended Real Time Oscilloscope
- PicoSample 4 software on USB stick
- Quick start guide
- 12 V DC at 3.34 A AC/DC adaptor
- AC power cord
- USB 2.0 cable, 1.8 m
- N / SMA / PC3.5 / K wrench
- Storage and carry case

A range of optional accessories is available from Pico. Please see the [PicoScope 9400 Series data sheet](#) for details.

3.2 Connections

Standard oscilloscope connectors

The PicoScope 9400 Series oscilloscopes have SMA connectors on all channel inputs, prescaled trigger input (PicoScope 9404-16 only), calibrator and trigger outputs, and also the optional clock and data recovered outputs.

The inputs have an impedance of 50Ω , so they are compatible with low-impedance oscilloscope probes having different attenuation or gain.

Connector diagrams (9404 models)

Front panels



- Power LED
- Status LED
- Channel 1 Input
- Channel 2 Input
- Channel 3 Input
- Channel 4 Input
- Calibrator Output
- Prescale Input (PicoScope 9404-16 only)
- Trigger Output

Rear panel (from left to right)

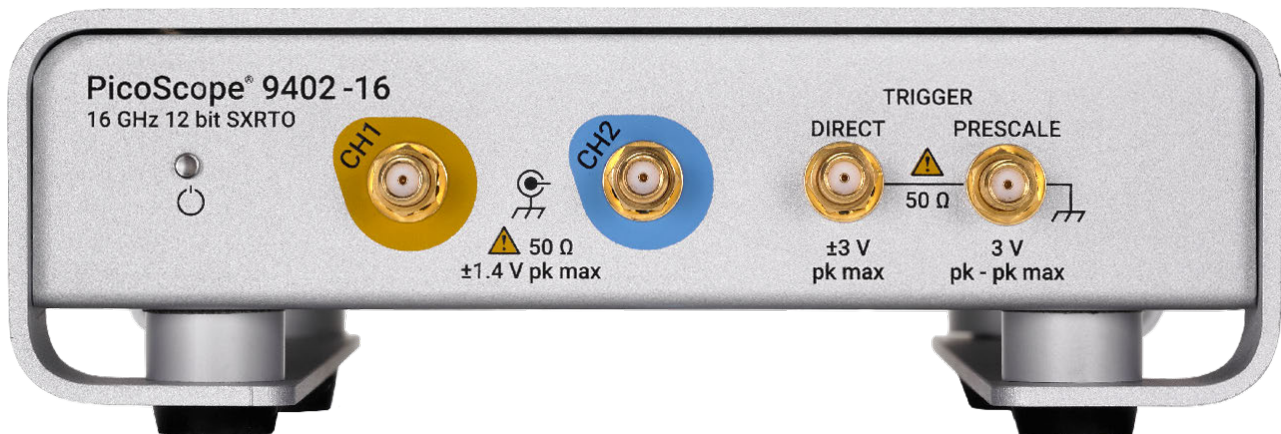

- LAN Reset Switch
- USB 2.0 port
- LAN port
- Recovered Clock Output (optional)
- Recovered Data Output (optional)
- Power socket: for use with the AC adaptor supplied with the unit
- Earth terminal

Connector diagrams (9402 models)**Front panels (from left to right)**

- Power LED
- Channel 1 Input
- Channel 2 Input
- Direct Input
- Prescale Input (PicoScope 9402-16 only)

Rear panel (from left to right)

- Recovered Clock Output (optional)
- Recovered Data Output (optional)
- USB 2.0 port
- Power socket: for use with the AC adaptor supplied with the unit
- Earth terminal

Air vents

There is a low-noise fan inside the unit, which blows air through the holes on the back and front panels.

**CAUTION**

Do not block the air vents at the back or front of the instrument as overheating will damage the oscilloscope.

**CAUTION**

Do not insert any objects through the air vents as internal interference will cause damage to the oscilloscope.

4 How to use your oscilloscope

For safety information and additional instructions, please refer to the [PicoScope 9400 Series Quick Start Guide](#) supplied with your oscilloscope.

4.1 Acquiring, triggering and displaying waveforms

To use the PicoScope 9400 Series oscilloscope to measure or monitor waveforms, you need to know how to acquire, select, and display those waveforms properly. To help you do so, this section describes how to do the following tasks:

- How to couple waveforms to the oscilloscope channels.
- How to select channels to turn on and off their display.
- How to size and position the selected channel on screen.
- How to use the menus to set vertical (offset, bandwidth) and horizontal (time base, record length, and so on) parameters.

This section also describes how to choose the appropriate trigger, acquisition mode for acquiring your waveform, and how to customize the display.

Coupling waveforms to the oscilloscope

Pico Technology produces a variety of probes and cables suitable for connecting various types of signals to the input channels of this product.

The PicoScope 9400 Series oscilloscopes ship without probes. Because the oscilloscopes have 50 Ω input impedance and higher bandwidth, we recommend that you order and use the probes listed on the *PicoScope 9400 Series Data Sheet*.



Setting up automatically

The PicoScope 9400 Series oscilloscopes can automatically obtain and display a stable waveform of usable size. They can also be reset to its factory default settings.

Autoscale automatically sets up the front panel controls based on the characteristics of the input signal. It is much faster and easier than a manual control-by-control setup. Autoscale adjusts controls in the **Channels**, **Acquire** and **Trigger** menus.

To autoscale the oscilloscope

Do the following steps to automatically set up the oscilloscope:

1. Click the channel selection button (such as **Ch1** ) corresponding to your input channel to make it active.
2. Click the **Autoscale...**  button. If you use **Autoscale** when one or more channels are displayed, the oscilloscope selects the lowest numbered channel for horizontal scaling and triggering. Vertically, all channels in use are individually scaled. If you use **Autoscale** when no channels are displayed, the oscilloscope will turn on all channels and scale them.

To reset the oscilloscope

To reset the oscilloscope to its factory default settings, right-click **Default Setup...** ,

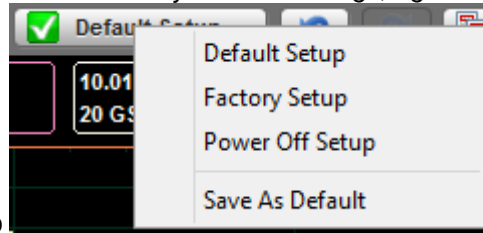

then click **Factory Setup**

Changing vertical scale, offset and position



You can use the vertical **Scale** to change the volts per division setting for any channel to increase or decrease the amplitude of your waveform.

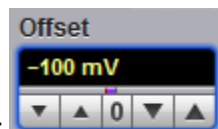

You can use the vertical **Offset** to move your waveform either up or down on the display. Each channel has a ground marker located to the left of the waveform display area which shows you where zero volts is for each channel.



You can use the vertical **Position** to move your waveform either up or down on the display within the ADC's dynamic range.

Sampling modes

There are three sampling modes that acquire the sample points used in reconstructing a waveform: real time sampling, random equivalent time sampling and roll mode.

Real time sampling mode



- Use this mode for waveforms with frequency components less than $\frac{1}{4}$ the sampling rate. At the maximum sampling rate of 500 MS/s you can use this mode for frequencies up to 125 MHz.
- Use this mode to capture waveforms that occur infrequently.
- Use this mode for single-shot waveform events.

1. Connect a 125 MHz sine wave having 600 mV pp amplitude to the input of channel 1.

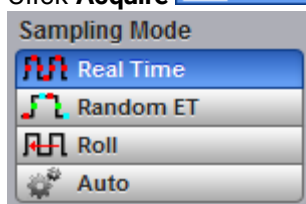
2. Click **Acquire** , then **Time Base**  **Acquisition**  **Zoom** , then **Real Time**

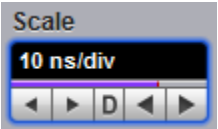
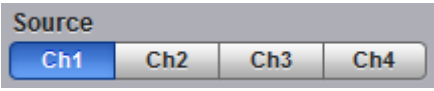
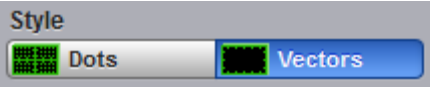

from the **Sampling Mode** menu.

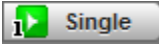
- 

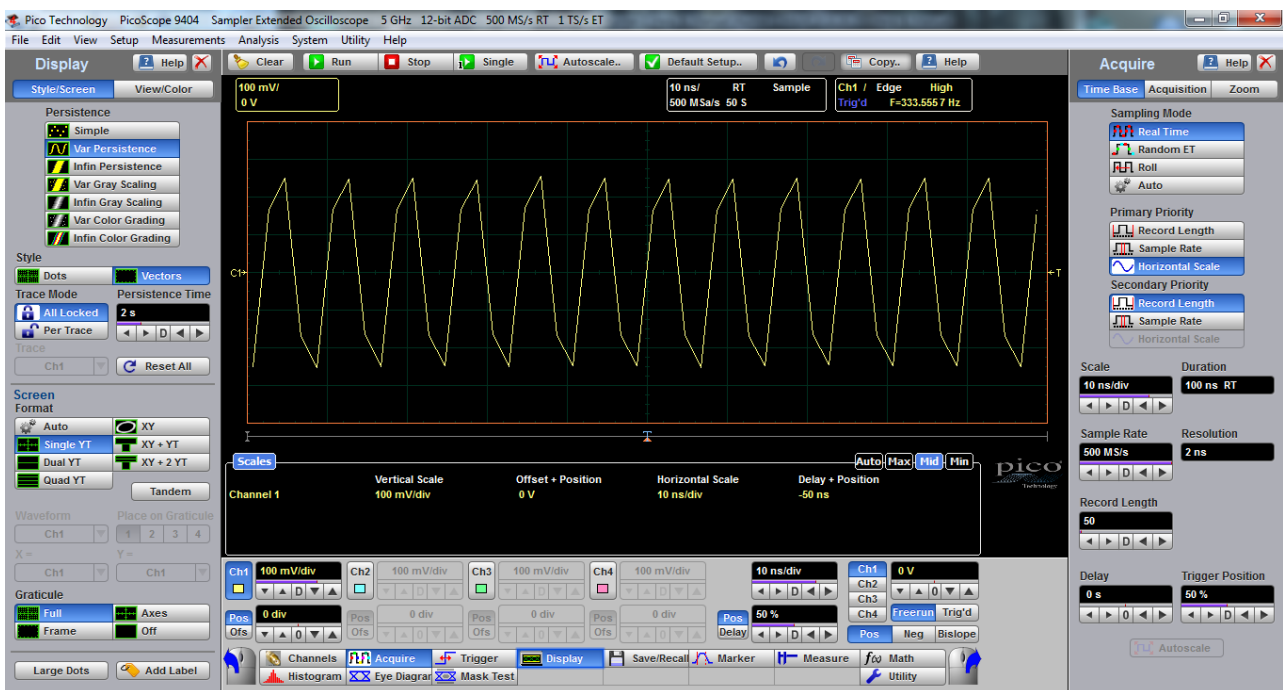
- 
- 
- 

- 



- If necessary use linear or [sin\(x\)/x interpolation](#).

Random equivalent time sampling

Random equivalent-time sampling acquires sample points over several trigger events and requires the input waveform to be repetitive. On each trigger event, the scope acquires more points and combines them with the previously acquired points. This creates a record of the waveform that has an effective sampling rate that is the inverse of the sample spacing.

This sampling mode also works at 500 MS/s sampling rate, but maximum equivalent sampling rate is 2.5 TS/s (0.4 ps sampling interval, PicoScope 9404-16 and PicoScope 9402-16) and 1 TS/s (1 ps sampling interval, PicoScope 9404-05 and PicoScope 9402-05).

- Use this mode for fast, repetitive waveforms.
- Use this mode for waveforms with frequency components greater than ¼ the scope's maximum sample rate.

- Use this mode for making more accurate measurements on repetitive waveforms.

1. Connect a 1 GHz sinewave having 600 mV pp amplitude to the input of channel 1.

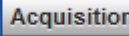
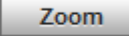
2. Click **Acquire**  **Acquire**, then **Time Base**  **Time Base**  **Acquisition**  **Zoom**, then **Random ET**

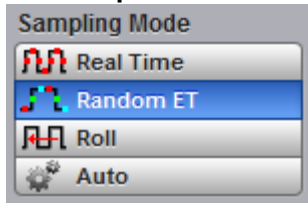

from the **Sampling Mode**.

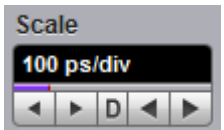
3. Select 100 mV/div vertical scale , 100 ps/div  horizontal scale, and

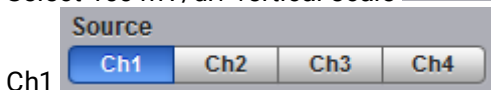

Ch1 as a trigger source.

4. Monitor a repetitive 1 GHz sine wave.

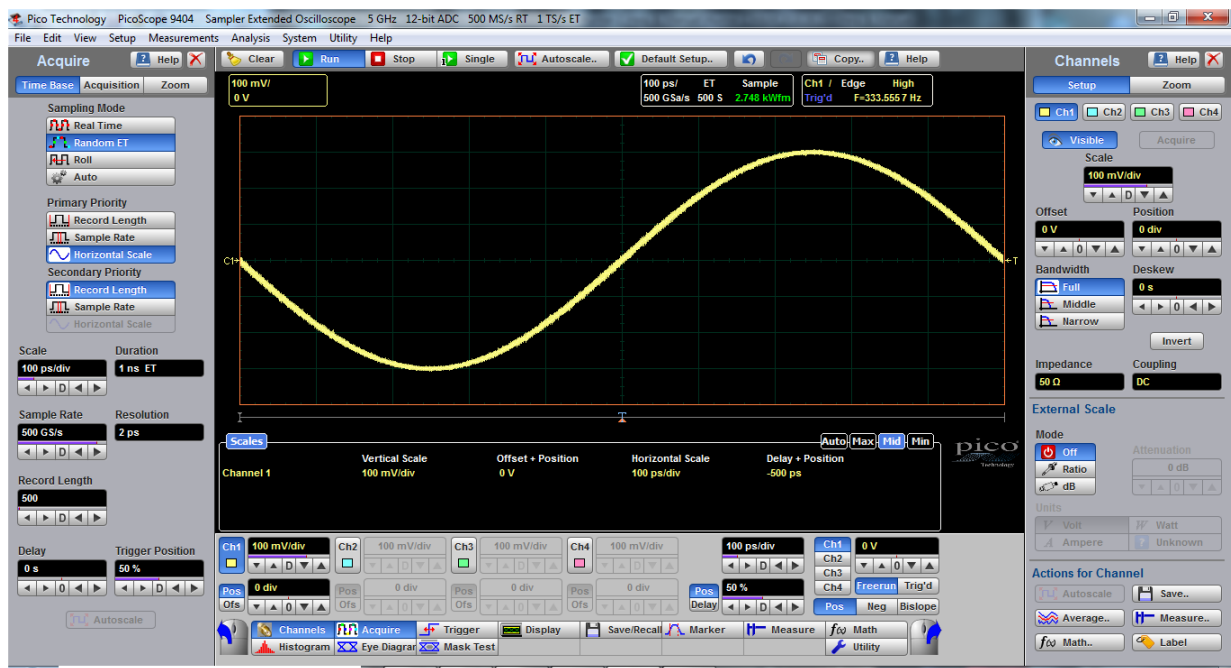

5. Use waveform [averaging](#) if level of noise or jitter exceeds acceptable for your measurements.

4.2 Measuring waveforms

To make the best use of the PicoScope 9400 Series oscilloscope when taking measurements, you need to know how to use all types of measurements it can take. This section describes how to take these measurements.

The types of measurements are:

- **Graticule** for making quick estimates by counting graticule divisions on the screen.
- **Marker** for measuring the difference (either in time or voltage) between two locations in a waveform record.
- **Automated** measurements for automatically taking and displaying waveform measurements.
- **Histogram** for displaying and automatically measuring how your vertical and horizontal units vary in the histogram box.
- **Masks** for mask counting, selecting a mask, or editing a mask.
- **Eye diagram** measurements for NRZ and RZ waveforms.

4.2.1 Graticule measurements

PicoScope 9400 Series oscilloscopes provide a graticule for measuring the difference (either in time or amplitude) between two points on a waveform record. Graticule measurements provide you with quick visual estimates. For example, you might look at a waveform amplitude and say “it is just over 200 mV.” This section briefly describes how to take graticule measurements.

Measure waveform amplitude

To measure the amplitude of a waveform, do the following steps:

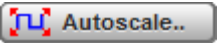
1. Connect pulse generator to the input of channel 1.
2. Set pulse frequency to 10 MHz, pulse width to 50 ns, rise and fall time to 10 ns, amplitude to 600 mV and offset to -300 mV
3. In PicoScope 4, click **Autoscale...** .
4. Count the graticule divisions between two features to be measured and multiply by the vertical scale factor.

For example, if you count four major vertical graticule divisions between the minimum and maximum values of a waveform at a scale factor of 150 mV/division, then you can easily calculate your peak-to-peak voltage as:

$$4 \text{ divisions} \times 150 \text{ mV/division} = 600 \text{ mV}.$$

Measure waveform time

To measure the time of a waveform, repeat the process just described, but count the horizontal divisions and multiply by the horizontal scale factor. For example, if you count three major horizontal graticule divisions for one waveform cycle at a horizontal scale factor of 33.33 ns/division, then you can easily calculate the waveform period as:

$$3 \text{ divisions} \times 33.33 \text{ ns/division} = 100 \text{ ns, or } 10 \text{ MHz}.$$

4.2.2 Marker measurements

The PicoScope 9400 Series oscilloscopes provide markers that measure the difference (either in time or voltage) between two locations in a waveform record. This section describes markers – how to select their type and mode, how to display them, and how to use them to take measurements.

Marker measurements are fast and easy to take. Markers are made up of two markers that you position with the variable or with the mouse. You move one marker independently or both markers in tandem (paired), depending on the **Motion** menu. As you position the markers, readouts on the display report and update measurement information.

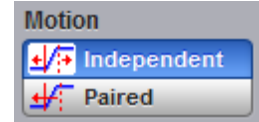

Marker readouts

The marker readout shows the absolute location of both markers and the difference between them. The readouts differ depending on the marker type you select: X-Marker, Y-Marker and XY-Marker.

The value after "dYM" shows the voltage difference between the markers. The value after "YM" shows the voltage of the marker relative to ground (see figure below). The value after "dXM" shows the time difference between the markers. The value after "XM" shows the time of the selected marker relative to the trigger point. The value after "1/dXM" shows frequency value equivalent to the time difference between the markers.

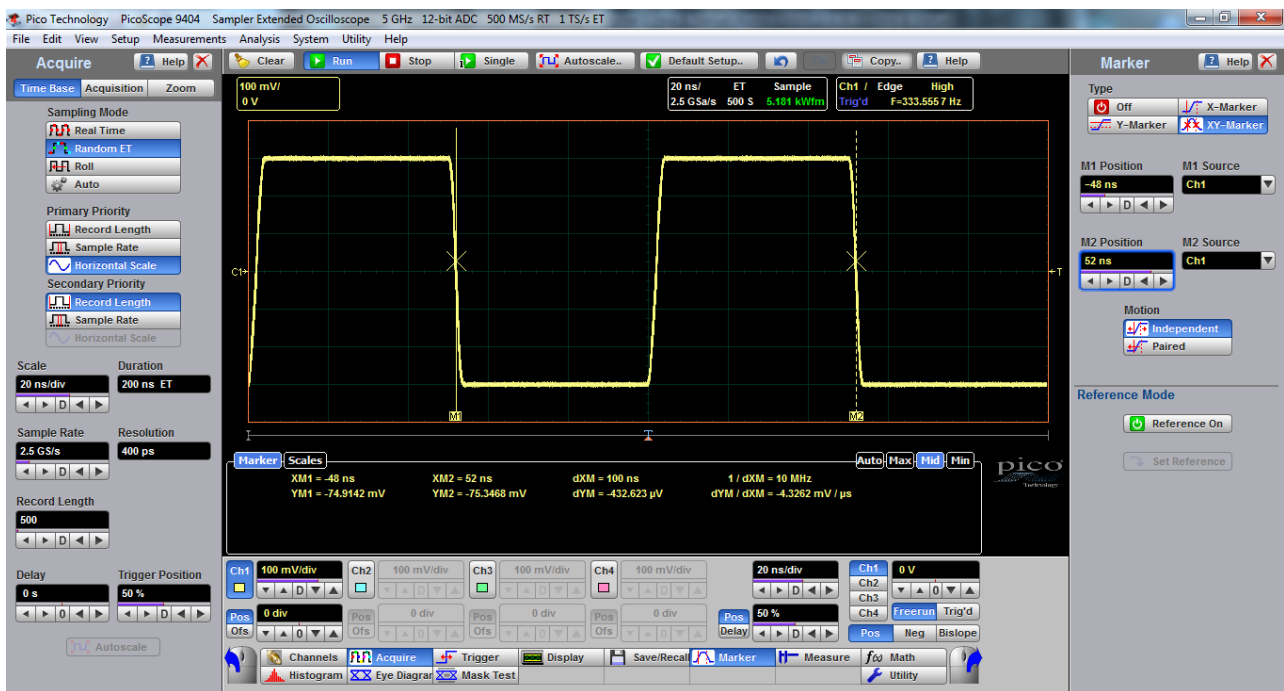

Marker function

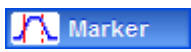
- To display the marker menu, click **Marker** .

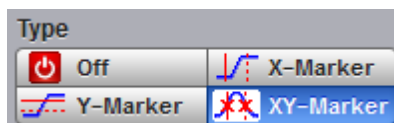

- Select the type of marker from the **Type** menu.

Set motion and adjust the markers

To select the motion mode and adjust the marker in either mode, do the following:

1. Click **Independent** or **Paired** from the **Motion** menu. **Independent** makes each marker positionable without regard to the position of the other marker. **Paired** makes both markers positionable in tandem; that is, both markers move in unison and maintain a fixed horizontal or vertical distance apart.

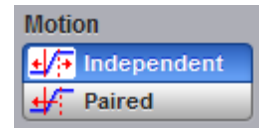

2. Adjust the markers according to the mode you have selected:

- To adjust either marker in independent mode, use the **M1 Position** and **M2 Position**

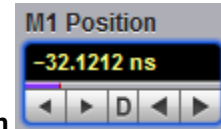
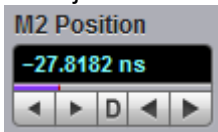

- To adjust both markers in paired mode, use the **M1 Position**

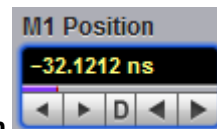

- To adjust the distance between markers in paired mode, use the **M2 Position**

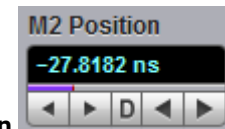

4.2.3 Automated measurements

PicoScope 9400 Series oscilloscopes can measure many waveform parameters automatically and show the results on display. Follow the procedure below to set up the oscilloscope to measure waveforms automatically.

Display measurements automatically

To use the automated measurement system, you must have a stable display of your signal. Also, the waveform must have all the features necessary for the measurement you want. For example, a rise time measurement requires at least one rising edge, and a frequency measurement needs at least one complete cycle.

To take automated measurements, proceed as follows:

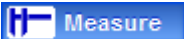
1. Connect a pulse generator to the input of channel 1.
2. Set pulse frequency to 10 MHz, pulse width to 50 ns, rise and fall time to 10 ns, amplitude to 600 mV and offset to -300 mV
3. In PicoSample 4, click **Autoscale...** .
4. Click **Measure...**  to display the **Measure** menu.

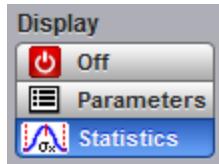

- Click **Statistics...** in the **Display** menu.
- Successively click **Frequency**, **Pos Width** and **Rise Time** in the **X Parameters** menu, then **Amplitude** in the **Y Parameters** menu. Observe that the measurement results with statistics appear in the [Measurement Area](#) of the screen. The measurement readout includes the notation Ch1, meaning that the measurement is taken on the channel 1 waveform.

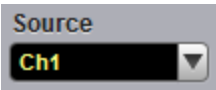
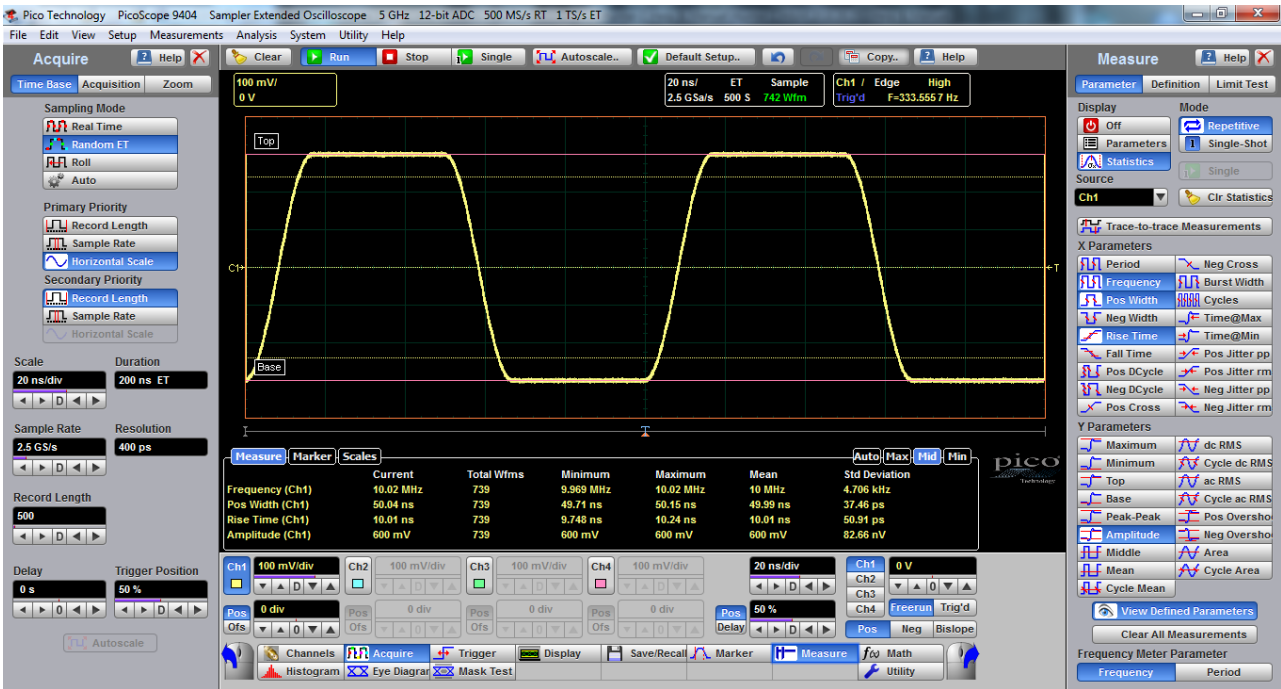

- To take a measurement on another channel, select that channel from **Source**, and then select the measurement.

4.2.4 Histogram measurement

PicoScope 9400 Series oscilloscopes can display histograms constructed from the selected trace waveform data. You can display either a vertical or horizontal histogram. You can display only one type of histogram at a time.

1. Start histogram counting

To start histogram counting click **Histogram...**, then select the type of axis – **Vertical** or

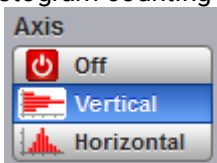

Horizontal

Off turns off histogram counting and display.

2. Histogram scaling

Vertical displays a vertical histogram that shows how your vertical units vary in the histogram box. A vertical histogram is displayed starting at the left edge of the graticule. The size of the max bin is

controlled by the **Window/Scale** and **Scale Type** menus and the **Scale** variable. If you select **Linear**, you display the count in each bin. If you select **Logarithmic**, you display the log of the count in each bin. Logarithmic scaling provides better visual detail for bins with low count.

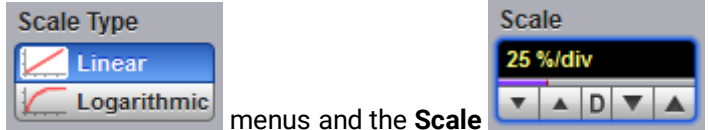

Horizontal displays a horizontal histogram that shows how time varies in the histogram box. A horizontal histogram is displayed at the bottom of the graticule. The size of the max bin is also controlled by the

Window/Scale and **Scale Type** menus and the **Scale** variable.

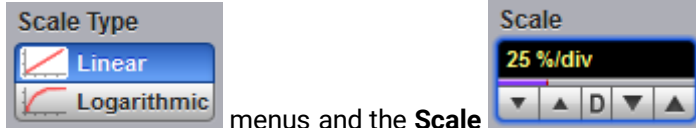

3. Reset histogram counting

To reset the count in all histogram bins to zero, click **Clear** .

4. Display a histogram

To select which waveform is compared against the histogram box, select the histogram source using



5. Setting histogram limits

The histogram limits select the section of the trace used for histograms. To set the size of the histogram box, click **Window/Scale** and then use the left, right, top and bottom limits.

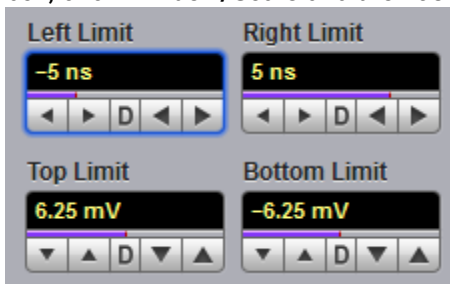

6. Display histogram measurements

a) To display histogram measurements you first need to obtain a stable display of your waveform.

Once you have a stable display, click **Histogram...**  **Histogram**, then select the type of axis –

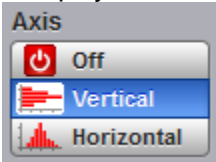
Vertical or **Horizontal** .

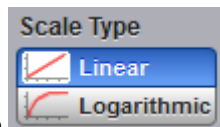

- b) Click the **Scale Type** menu and select a scale type.
- c) Make selections from the **Limits** menus.
- d) Make selections from the **Scale** menus.
- e) Control histogram statistics via the histogram measure tab located in the [Measurement Area](#).

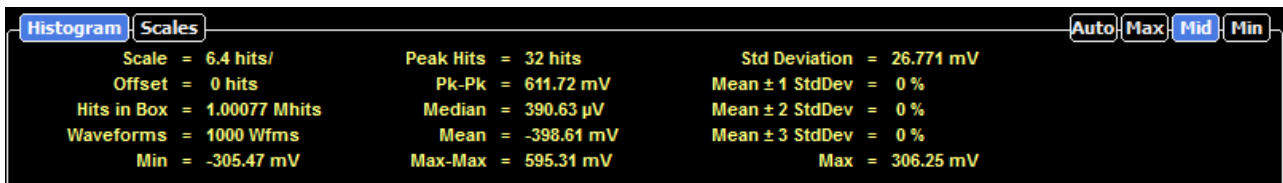

4.2.5 Eye diagram measurements

PicoScope 9400 Series oscilloscopes can precisely measure NRZ or RZ eye diagrams with up to 8 Gb/s data rate (PicoScope 9404-16 and PicoScope 9402-16) and up to 5 Gb/s data rate (PicoScope 9404-05 and PicoScope 9402-05).

As an example use the following procedure to make NRZ eye diagram measurements.

1. Connect a data signal to the selected channel (suppose this is the first channel). Use internal clock recovery, if available, as a trigger style.

2. Click **Trigger** **Trigger**.

3. Select **Ch1** from the **Source** menu.

4. Select **Clock Recovery** (if available) or alternatively **Edge** from the **Style** menu.

5. Click **Autoscale...** **Autoscale..**.

6. To make eye diagram measurements, click **Eye Diagram** **Eye Diagram**.

7. Select **NRZ** from the **Measure** menu.

8. Select the necessary parameters from the **X NRZ Parameters** and **Y NRZ Parameters** menus.
9. Control eye diagram statistics via the **Measure** tab located in the [Measurement Area](#).

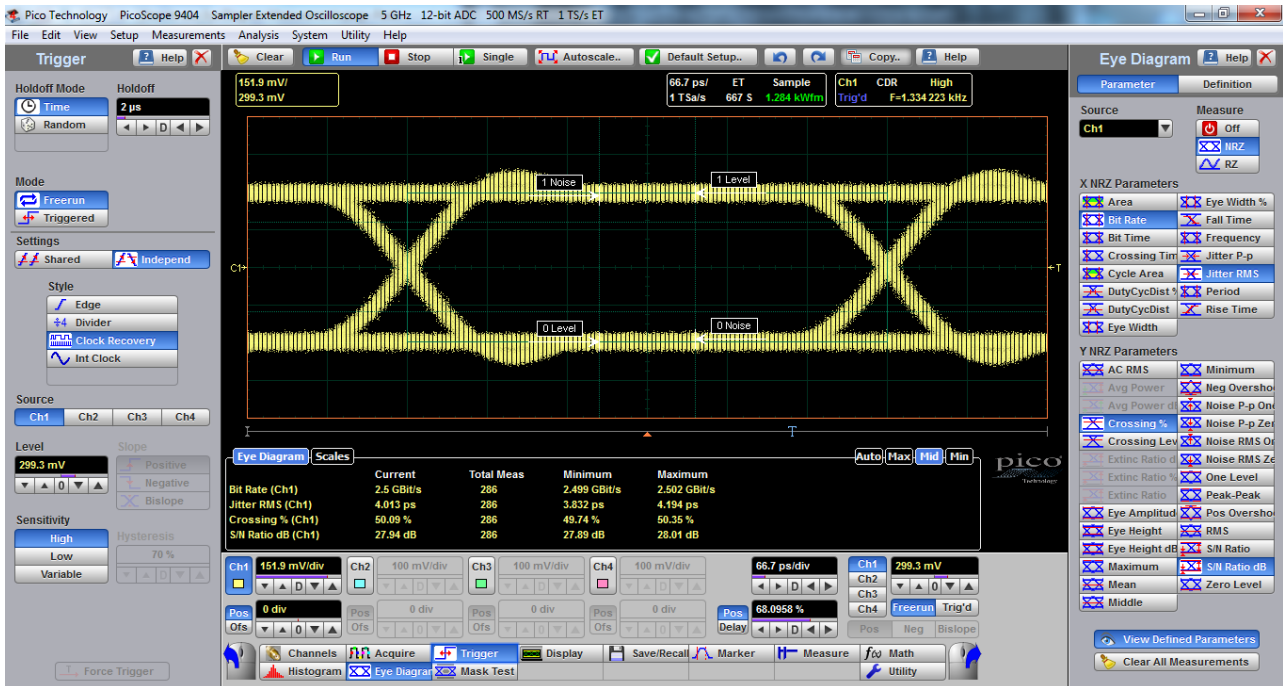

4.2.6 Mask test

The PicoScope 9400 Series oscilloscopes provide a portfolio of standard communication masks having data rates up to 5 Gb/s (PicoScope 9404-16 and PicoScope 9402-16) and up to 3.125 Gb/s (PicoScope 9404-05 and PicoScope 9402-05) for verifying compliance to electrical standards.

Below you will find the mask test procedure for the SONET/SDH STM16/OC48 2.48832 Gb/s standard.

1. Connect a data signal to the selected channel (suppose this is the first channel). Use internal clock recovery as a trigger style.

2. Click **Trigger** 

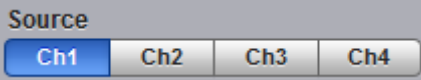
3. Select **Ch1**  from the **Source** menu.

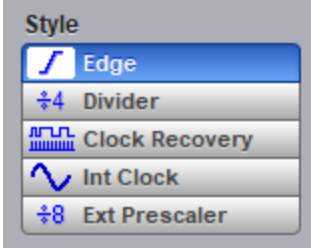
4. Select **Clock Recovery**  (if available) or alternatively **Edge** from the **Style** menu.

5. Click **Autoscale...** . The oscilloscope shows 2.5 Gb/s eye diagram.

6. Click **Mask Test** .

7. Select **Ch1**  from the **Compare with** menu.

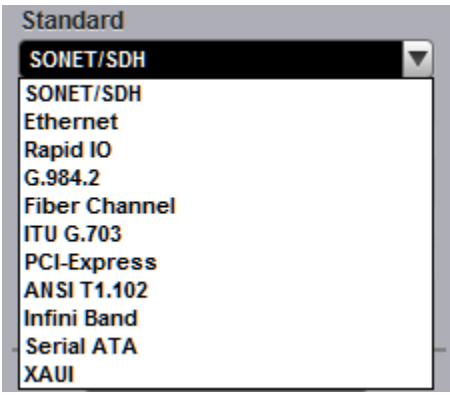
8. Select **SONET/SDH**  from the **Standard** menu.

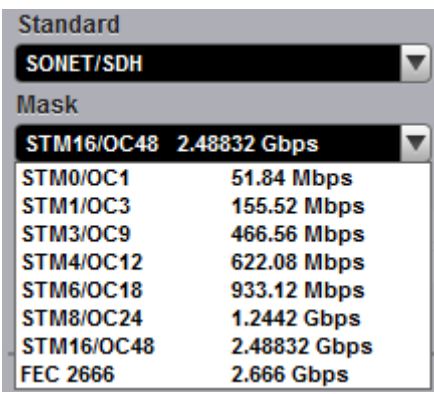
9. Select **STM/OC48 Mask**  from the **SONET/SDH** menu.

10. Click **Build** . Verify the mask that is built.

11. Click **Margins**, then select the value of the margin . Verify the mask with built margins.

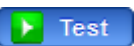
12. Click **Test** . You can read the results listed in the [Measurement Area](#). These values are displayed on tabs. Notice that any acquired data point that falls inside a mask or a mask margin appears in red.

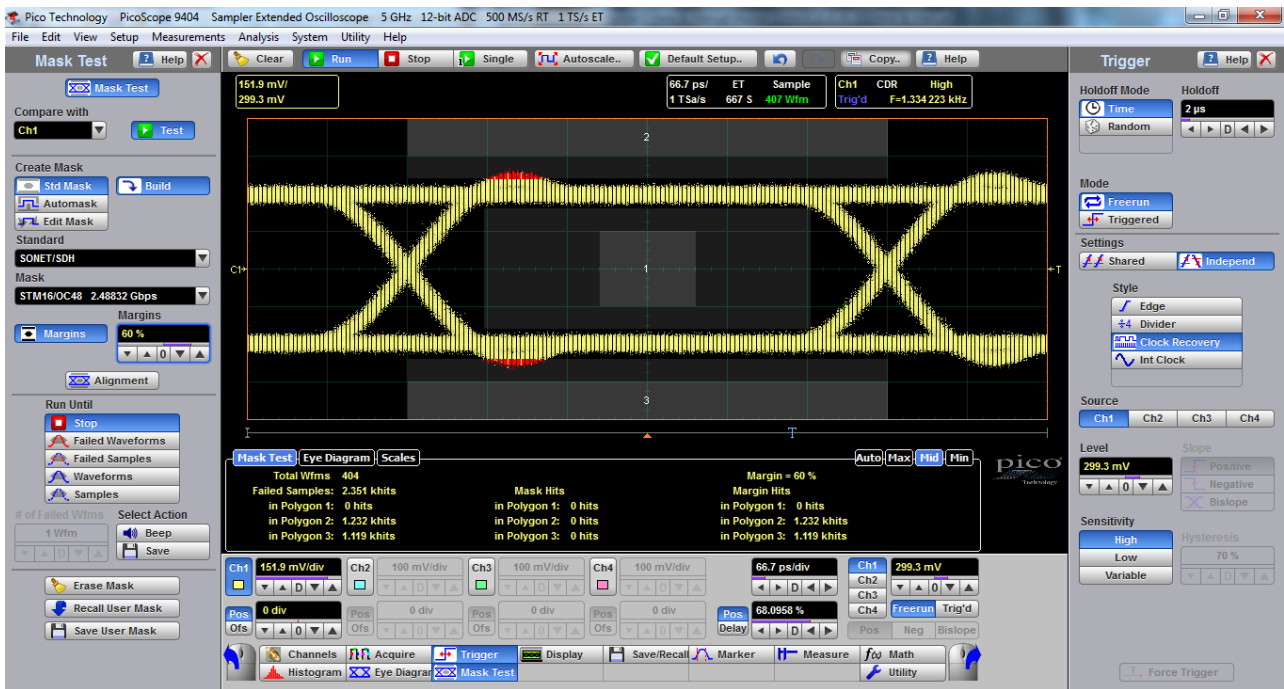

4.3 Waveform math

The PicoScope 9400 Series oscilloscopes provide a means for you to mathematically manipulate your waveforms.

To use single waveform math

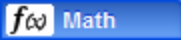
To perform waveform math, use the **Math** menu . This menu allows you to display, define, and manipulate up to four math functions. The following steps explain how to create a math waveform based on a single source waveform.

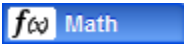
1. Connect a 1 kHz sine wave having 600 mV pp amplitude to the input of channel 1.
2. Click **Autoscale...** . Note the acquired 1 kHz sine wave.
3. Click the **Math** menu , then the **Function**.

4. Select **Ch1** from the **Operand 1** menu .

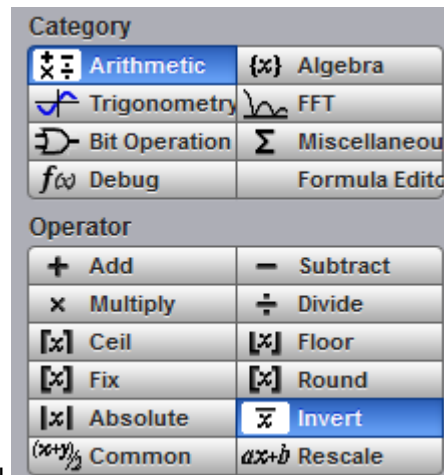

5. Select **Arithmetic** from the **Category** menu, then select **Invert** from the **Operator** menu.

6. Click **F1** , then click **On** .

7. Note both the channel 1 waveform and the inverted math waveform.

To use dual waveform math

1. Connect a 1 kHz sine wave having 600 mV pp amplitude to both inputs of channel 1 and channel 2 using a power splitter.
2. Click **Autoscale...** . Note the acquired 1 kHz sine wave on both channels.
3. Click the **Math** menu , then the **Function**.
4. Select **Ch1** from the **Operand 1** menu, and **Ch2** from the **Operand 2** menu.
5. Select **Arithmetic** from the **Category** menu, then select **Add** from the **Operator** menu.

6. Click **F1** , then click **On** .

7. Note channel 1, channel 2 and the math sum of both waveforms.

4.4 Connecting using LAN or USB interfaces (not 9402 models)

Factory settings for PicoScope 9400 Series oscilloscopes

MAC address: See the underside of your scope.
 IP address: 192.168.0.221
 Subnet Mask: 255.255.255.0
 Gateway: 192.168.1.27

To change the LAN interface settings, first [Configure Common LAN Settings](#) in the PicoSample 4 software, then [Configure the oscilloscope LAN Settings](#), and then [Configure other PicoSample 4 software LAN settings](#).

4.4.1 Select current interface

4.4.1.1 Algorithm for determining current interface

The PicoScope 9400 Series oscilloscope detects the current interface automatically within the first 20 seconds after power is turned on.

1. Within the first 7 seconds after power up, the instrument checks the USB connection with the PC. At this time, the lower front panel LED flashes green with a period of about 0.5 s. If during this time the instrument detects a USB connection, the current interface will be set to USB.
2. If the USB interface is not detected during first 7 seconds, then, for the next 13 seconds, the instrument checks the LAN connection. During this time the lower LED lights up orange. The orange LED on the LAN connector on the back panel also lights up. If the instrument detects a LAN connection during this time, the instrument's current interface will be set to LAN.
3. If after 20 seconds the current interface is still undefined, it will be set to USB.

Note: The current interface selected at any of the three stages will remain in the device until the power is turned off.

4.4.1.2 Connecting to USB

1. Basic procedure:
 - Turn off the oscilloscope.
 - Connect the oscilloscope to your PC using the USB cable provided.
 - Turn on the oscilloscope.
2. Alternative procedure (valid if there is no LAN connection):
 - Turn off the scope.
 - Turn on the scope.
 - Connect the scope to your PC using the USB cable provided.

4.4.1.3 Connecting to LAN

Note. Before switching on the instrument to LAN, make sure that there is no USB connection.

1. Basic procedure:
 - Turn off the scope.
 - Connect LAN connector to Local Area Network (LAN).
 - Turn on the scope.
2. Alternative procedure:
 - Turn off the scope.

- Turn on the scope.
- During first 20 seconds after switching on the instrument, connect it to LAN.

4.4.2 Configure common LAN Settings

The general LAN settings of the PicoSample 4 software should be consistent with your network settings. Discuss these settings with your LAN administrator.

The PicoSample 4 software can select any one from a total of eight PicoScope 9400 Series LAN units found on the network.

Common LAN settings include:

- Subnet mask.
- Gateway
- Zone of PicoScope 9400 IP addresses.

After installation, PicoSample 4 software has the following Common LAN Settings:

- Subnet mask 255.255.255.0
- Gateway 192.168.0.1
- Zone of PicoScope 9400 IP addresses 192.168.0.221 ... 192.168.0.229

To check or change Common LAN Settings, do the following:

1. Start the PicoSample 4 software (Demo mode is also suitable).
2. Select **System > Common LAN Settings** from the top menu bar.

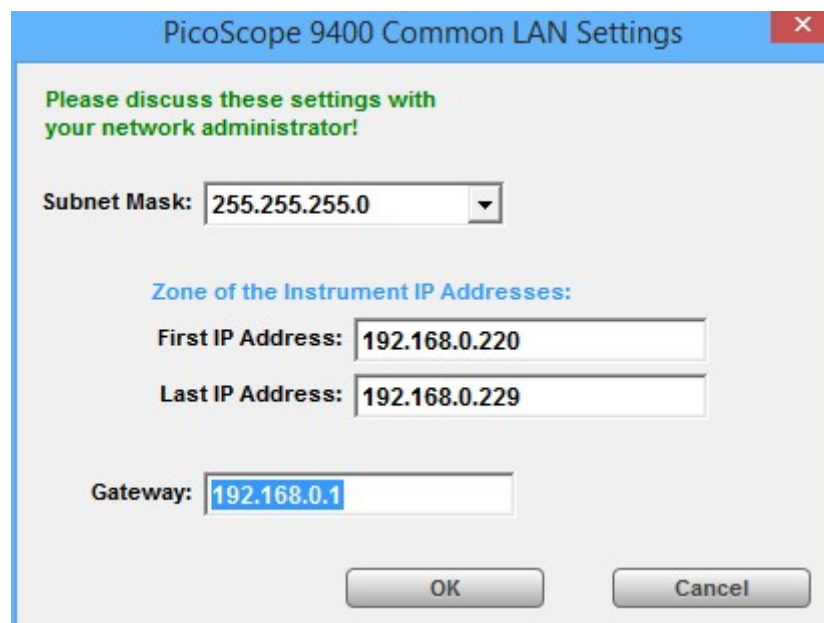

3. Set the required Common LAN Settings and click **OK**.

4.4.3 Configure the oscilloscope's LAN settings

Before connecting the PicoScope 9400 Series oscilloscope to a LAN, it is necessary to enter the correct LAN settings. To do this, follow the instructions below.

1. [Connect the scope to your PC via USB.](#)
2. Run the PicoSample 4 software.
3. Right click on the **Help/About../TCP/IP Properties**. The **TCP/IP Properties** dialog opens.
4. Compare the current LAN settings with the desired ones. If the oscilloscope's LAN settings are correct, close the dialog.
5. Click the **Set TCP / IP New Properties** and check the correctness of the Common LAN Settings in the **Confirm** box.

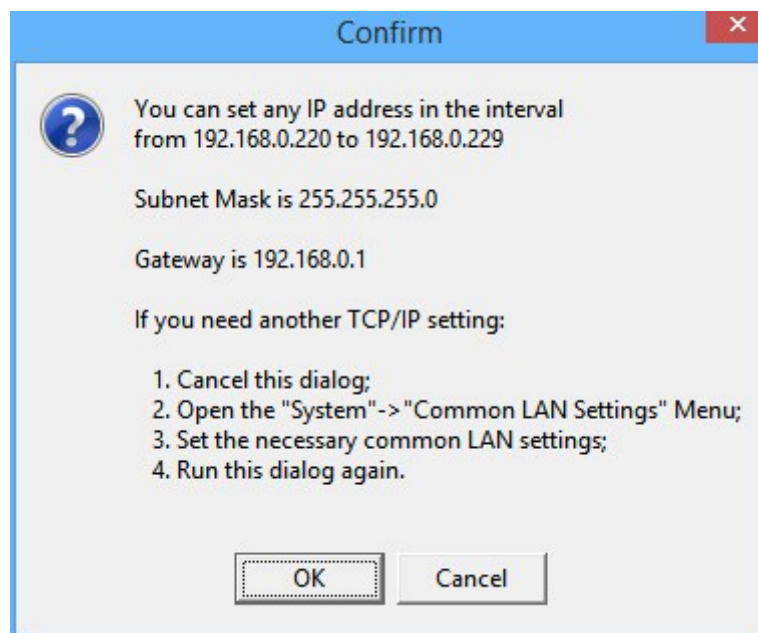

6. If the required IP-address is within allowed range, and the Subnet Mask and Gateway are correct, click **OK**. Otherwise close all dialogs and [Configure common LAN settings](#).
7. Enter the new IP address and click **Store**.

4.4.4 Configure other PicoSample 4 software LAN settings

Further configuration is done in 2 stages:

- [Set up a list of LAN oscilloscopes serviced by PicoSample 4](#)
- [Set the startup mode of PicoSample 4](#)

4.4.4.1 Set up a list of LAN oscilloscopes serviced by PicoSample 4

1. [Set the correct LAN Settings](#) in all PicoScope 9400 Series units that should work with this copy of the PicoSample 4 software.

Note: IP addresses must be different in all PicoScope 9400 Series units.

2. [Connect](#) all these oscilloscopes to the LAN.
3. Start PicoSample 4 (Demo mode is also suitable).
4. Select **System > Scanning LAN Instruments** from the top menu bar.

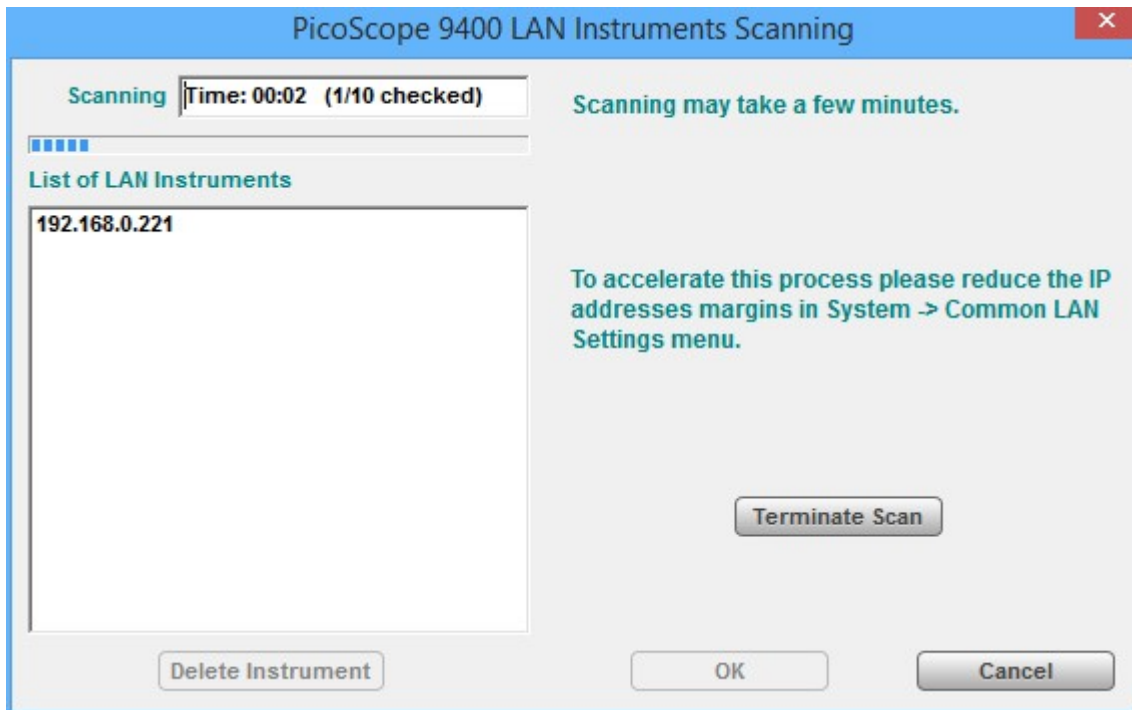

5. PicoSample 4 starts scanning IP addresses at a specified interval (see [Configure Common LAN Settings](#)). The scanning process can take a long time. However, if the IP addresses of all connected PicoScope 9400 Series scopes have already appeared in the **List of LAN Instruments** window, further scanning can be stopped by clicking **Terminate Scan**.
6. Click **OK**.

Note: PicoSample 4 is now configured to work with any LAN device from this list.

4.4.4.2 Set the startup mode of PicoSample 4

Select **System> Change Instrument** bar from the top menu bar. The **PicoScope 9400 Change Instrument** dialog opens.

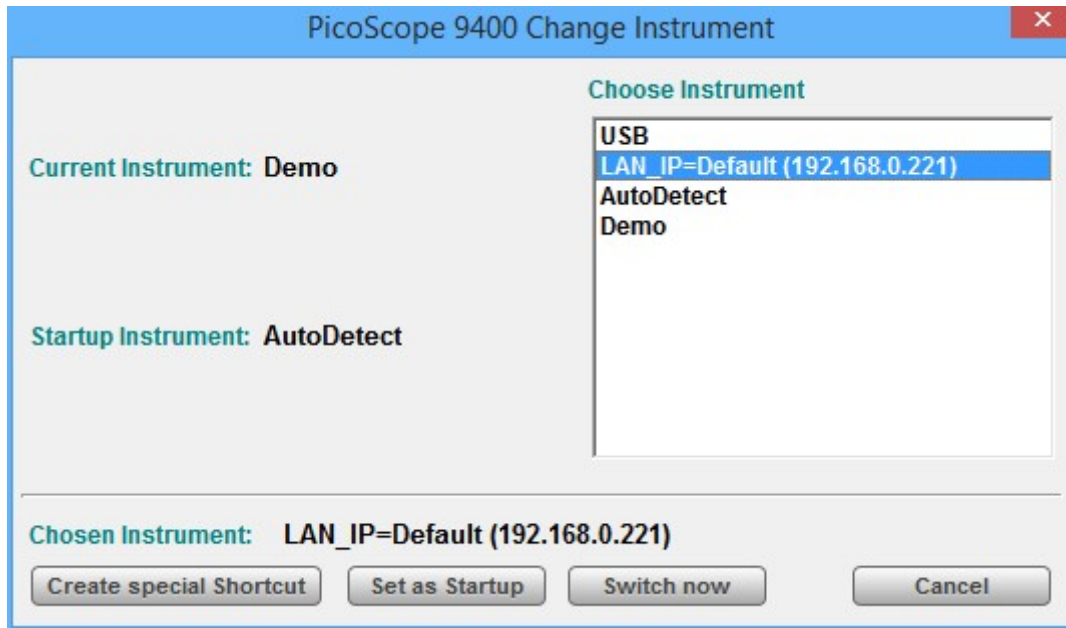

Using this dialog you can do the following:

- Immediately switch PicoSample 4 to work with the selected device or in a demo mode.
- Set up PicoSample 4 so that it is connected to a specific device at startup.
- Create a special shortcut for PicoSample 4 on your desktop to work with a specific PicoScope 9400.

To do this, follow the following steps:

1. Select the desired PicoScope 9400 in the **Choose Instrument** window.
2. Click **Switch now** for immediate switching of PicoSample 4 to the specified instrument.
3. Click **Set as Startup** to set up PicoSample 4 to work with a specific device at startup. It is recommended to select **AutoDetect** if PicoSample 4 is required to work with different instruments at different times.
4. Click **Create special Shortcut** to create a special PicoSample 4 shortcut to work with a specified PicoScope 9400 instrument.

5 Specifications and characteristics

Except where otherwise noted, the following specifications describe guaranteed performance within ± 2 °C of the most recent autocalibration temperature. All specifications apply after the instrument's temperature has been stabilized after 30 minutes of continuous operation.

Many performance parameters are enhanced through simple automated calibrations driven by time interval or change of temperature.

Specifications marked as **typical** are not guaranteed, but indicate the performance that most units will exhibit.

For optimum performance, the instrument should have a complete verification of specifications and possible adjustment once every 12 months.

All specifications are subject to change without notice.

Specifications marked with (*) are checked in the Performance Verification.

5.1 Vertical

Number of input channels	PicoScope 9404-16, PicoScope 9404-05: four channels. PicoScope 9402-16, PicoScope 9402-05: two channels. All channels are identical and digitized simultaneously
Analog bandwidth, -3 dB flatness	These specifications are valid after a 30-minute warm-up period and ± 2 °C from firmware calibration temperature.
* Full bandwidth	PicoScope 9404-16, PicoScope 9402-16: DC to 16 GHz guaranteed. PicoScope 9404-05, PicoScope 9402-05: DC to 5 GHz.
Middle bandwidth	PicoScope 9404-16, PicoScope 9404-05: DC to 450 MHz. PicoScope 9402-16, PicoScope 9402-05: N/A.
Narrow bandwidth	PicoScope 9404-16, PicoScope 9404-05: DC to 100 MHz. PicoScope 9402-16, PicoScope 9402-05: DC to 450 MHz
Passband flatness	Full bandwidth: PicoScope 9404-16, PicoScope 9402-16: ± 1 dB to 5 GHz. PicoScope 9404-05, PicoScope 9402-05: ± 1 dB to 3 GHz..
Calculated rise time (Tr), typical	Calculated from the bandwidth.

	10% to 90%: calculated from $T_r = 0.35/BW$. 20% to 80%: calculated from $T_r = 0.25/BW$.
Full bandwidth	PicoScope 9404-16, PicoScope 9402-16: 10% to 90%: ≤ 21.9 ps, 20% to 80%: ≤ 15.6 ps. PicoScope 9404-05, PicoScope 9402-05: 10% to 90%: ≤ 70 ps, 20% to 80%: ≤ 50 ps.
Middle bandwidth	PicoScope 9404-16, PicoScope 9404-05: 10% to 90%: ≤ 780 ps, 20% to 80%: ≤ 560 ps. PicoScope 9402-16, PicoScope 9402-05: N/A.
Narrow bandwidth	PicoScope 9404-16, PicoScope 9404-05: 10% to 90%: ≤ 3.5 ns. 20% to 80%: ≤ 2.5 ns. PicoScope 9402-16, PicoScope 9402-05: 10% to 90%: ≤ 780 ps, 20% to 80%: ≤ 560 ps.
Step response, typical	For PicoScope 9404-05 and 9402-05: only
Full bandwidth	Overshoot: $< 8\%$. Ringing: $\pm 6\%$ to 3 ns, $\pm 4\%$ from 3 ns to 10 ns, $\pm 3\%$ from 10 ns to 100 ns, $\pm 2\%$ from 100 ns to 400 ns, $\pm 1\%$ after 400 ns.
Middle bandwidth	Overshoot: $< 6\%$. Ringing: $\pm 4\%$ to 10 ns, $\pm 3\%$ from 10 ns to 100 ns, $\pm 2\%$ from 100 ns to 400 ns, $\pm 1\%$ after 400 ns.
Narrow bandwidth	Overshoot: $< 5\%$. Ringing: $\pm 5\%$ to 20 ns, $\pm 3\%$ from 20 ns to 100 ns, $\pm 2\%$ from 100 ns to 400 ns, $\pm 1\%$ after 400 ns.
RMS noise	
* Full bandwidth	PicoScope 9404-16, PicoScope 9402-16: 2.4 mV, maximum, 2.2 mV, typical. PicoScope 9404-05, PicoScope 9402-05: 1.8 mV, maximum, 1.6 mV, typical.
Middle bandwidth	PicoScope 9404-16, PicoScope 9404-05: 0.8 mV, maximum, 0.65 mV, typical. PicoScope 9402-16, PicoScope 9402-05: N/A
Narrow bandwidth	PicoScope 9404-16, PicoScope 9404-05: 0.6 mV, maximum, 0.45 mV, typical. PicoScope 9402-16, PicoScope 9402-05: 0.8 mV, maximum, 0.65 mV, typical.
Scale factors (sensitivity)	10 mV/div to 250 mV/div.

	Full scale is 8 vertical divisions. Adjustable in a 10-12.5-15-20-25-30-40-50-60-80-100-125-150-200-250 mV/div sequence. Also adjustable in 1% fine increments or better. With manual or calculator data entry the increment is 0.1 mV/div.
* DC gain accuracy	$\pm 2\%$ of full scale. $\pm 1.5\%$ of full scale, typical.
Position range	± 4 divisions from center screen
DC offset range	Adjustable from -1 V to $+1$ V in 10 mV increments (coarse). Also adjustable in fine increments of 2 mV. With manual or calculator data entry the increment is 0.01 mV for offset between -99.9 and 99.9 mV, and 0.1 mV for offset between -999.9 and 999.9 mV. Referenced to the center of display graticule.
* Offset accuracy	± 2 mV $\pm 2\%$ of offset setting. ± 1 mV $\pm 1\%$ of offset setting, typical.
Operating input voltage	± 800 mV
Vertical Zoom and Position	For all input channels, waveform memories, or functions.
Vertical factor	0.01 to 100.
Vertical position	± 800 divisions maximum of zoomed waveform.
Channel-to-channel crosstalk (channel isolation)	≥ 50 dB (316:1) for input frequency DC to 1 GHz. ≥ 40 dB (100:1) for input frequency > 1 GHz to 3 GHz. ≥ 36 dB (63:1) for input frequency > 3 GHz to = 5 GHz (PicoScope 9404-05, PicoScope 9402-05) and to ≤ 16 GHz (PicoScope 9404-16, PicoScope 9402-16).
Delay between channels	≤ 10 ps, typical. Between any two channels, full bandwidth, equivalent time.
ADC resolution	12 bits
Hardware vertical resolution	0.4 mV/LSB without averaging
Maximum safe input voltage	± 1.4 V (DC + peak AC)
* Input impedance	$(50 \pm 1.5) \text{ } \Omega$. $(50 \pm 1) \text{ } \Omega$, typical

Input match	PicoScope 9404-05, PicoScope 9402-05: Reflections for 70 ps rise time: 10% or less. PicoScope 9404-16, PicoScope 9402-16: Reflections for 50 ps rise time: 10% or less.
Input coupling	DC
Input connectors	SMA female
Internal probe power	PicoScope 9404-16, PicoScope 9404-05 only: 6 W maximum.
Probe power per probe	PicoScope 9404-16, PicoScope 9404-05 only: 3.3 V: 100 mA max. 12 V: 500 mA max. Sum of all probes subject to internal probe power limit.
Attenuation	Attenuation factors may be entered to scale the oscilloscope for external attenuators connected to the channel inputs.
Range	0.0001:1 to 1 000 000:1.
Units	Ratio or dB.
Scale	Volt, Watt, Ampere, or Unknown.

5.2 Horizontal

Timebase	Internal timebase common to all input channels.
Timebase range	Full horizontal scale is 10 divisions.
Real time sampling	10 ns/div to 1000 s/div.
Random equivalent time sampling	PicoScope 9404-16, PicoScope 9402-16: 20 ps/div to 5 μ s/div. PicoScope 9404-05, PicoScope 9402-05: 50 ps/div to 5 μ s/div.
Roll	100 ms/div to 1000 s/div.
Segmented	Total number of segments: 2 to 1024. Rearm time between segments: < 3 μ s.
Horizontal zoom and position	For all input channels, waveform memories, or functions

Horizontal factor	From 1 to 2000.
Horizontal position	From 0% to 100% non-zoomed waveform.
Timebase clock accuracy	
Frequency	500 MHz
Initial set tolerance	$\pm 10 \text{ ppm @ } 25 \text{ }^\circ\text{C} \pm 3 \text{ }^\circ\text{C}$
* Overall frequency stability	$\pm 50 \text{ ppm over operating temperature range}$
Aging	$\pm 7 \text{ ppm over 10 years @ } 25 \text{ }^\circ\text{C}$
Timebase resolution	At random equivalent time sampling: PicoScope 9404-16, PicoScope 9402-16: 0.4 ps. PicoScope 9404-05, PicoScope 9402-05: 1.0 ps.
* Delta time measurement accuracy	$\pm (50 \text{ ppm} * \text{reading} + 0.1\% * \text{screen width} + 5 \text{ ps})$
Pre-trigger delay	Record length / current sampling rate maximum at zero variable delay time
Post-trigger delay	0 to 4.28 s. Coarse increment is one horizontal scale division, fine increment is 0.1 horizontal scale division, manual or calculator increment is 0.01 horizontal scale division.
Channel-to-channel deskew range	$\pm 50 \text{ ns}$ range. Coarse increment is 100 ps, fine increment is 10 ps. With manual or calculator data entry the increment is four significant digits or 1 ps.

5.3 Acquisition

Sampling modes

Real time	Captures all of the sample points used to reconstruct a waveform during a single trigger event
Random equivalent time	Acquires sample points over several trigger events, requiring the input waveform to be repetitive
Roll	Acquisition data will be displayed in a rolling fashion starting from the right side of the display and continuing to the left side of the display (while the acquisition is running)

Segmented	Segmented memory optimizes available memory for data streams that have long rearm times between activity. Number of segments: up to 1024. Segments stamped with absolute and delta times.
Maximum sampling rate	
Real time	500 MS/s per channel simultaneously
Random equivalent time	PicoScope 9404-16, PicoScope 9402-16: Up to 2.5 TS/s or 0.4 ps trigger placement resolution. PicoScope 9404-05, PicoScope 9402-05: Up to 1 TS/s or 1.0 ps trigger placement resolution.
Record length	
Real time sampling	From 50 S/ch to 250 kS/ch for one channel, to 125 kS/ch for two channels, to 50 kS/ch for three and four channels.
Random equivalent time sampling	From 500 S/ch to 250 kS/ch for one channel, to 125 kS/ch for two channels, to 50 kS/ch for three and four channels.
Duration at highest sample rate	
	0.5 ms for one channel, 0.25 ms for two channels, 0.125 ms for three and four channels.
Acquisition modes	
Sample (normal)	Acquires first sample in decimation interval and displays results without further processing.
Average	Average value of samples in decimation interval. Number of waveforms for average: 2 to 4096.
Envelope	Envelope of acquired waveforms. Minimum, Maximum or both Minimum and Maximum values acquired over one or more acquisitions. Number of acquisitions is from 2 to 4096 in ×2 sequence and continuously.
Peak detect	Largest and smallest sample in decimation interval. Minimum pulse width: 1/(sampling rate) or 2 ns @ 50 µs/div or faster for single channel.
High resolution	Averages all samples taken during an acquisition interval to create a record point. This average results in a higher-resolution, lower-bandwidth waveform. Resolution can be expanded to 12.5 bits or more, up to 16 bits.

5.4 Trigger

Trigger sources

PicoScope 9404-16: Internal from any of four channels, External Prescaled.
PicoScope 9402-16: Internal from any of two channels, External Direct, External Prescaled.
PicoScope 9404-05: Internal from any of four channels.
PicoScope 9402-05: Internal from any of two channels, External Direct

Trigger mode

Freerun

Triggers automatically but not synchronized to the input in absence of trigger event.

Normal (triggered)

Requires trigger event for oscilloscope to trigger.

Single

Software button that triggers only once on a trigger event. Not suitable for random equivalent-time sampling

Trigger holdoff mode

Time or Random

Trigger holdoff range

Holdoff by time

Adjustable from 500 ns to 15 s in a 1-2-5-10 sequence or in 4 ns fine increments.

Random

This mode varies the trigger holdoff from one acquisition to another by randomizing the time value between triggers. The randomized time values can be between the values specified in the Min Holdoff and Max Holdoff.

5.4.1 Internal trigger

Trigger style

Edge

Triggers on a rising and falling edge of any source within frequency range DC to 2.5 GHz.

Divide

The trigger source is divided down four times (/4) before being applied to the trigger system. Maximum trigger frequency 5 GHz.

Clock recovery (optional)

PicoScope 9404-16, PicoScope 9402-16: 6.5 Mb/s to 8 Gb/s.
PicoScope 9404-05, PicoScope 9402-05: 6.5 Mb/s to 5 Gb/s.

Internal trigger bandwidth and sensitivity

Low sensitivity

100 mV p-p DC to 100 MHz.
Increasing linearly from 100 mV p-p at 100 MHz to 200 mV p-p at 5 GHz.
Pulse Width: 100 ps @ 200 mV p-p typical.

* High sensitivity

30 mV p-p DC to 100 MHz.
Increasing linearly from 30 mV p-p at 100 MHz to 70 mV p-p at 5 GHz.
Pulse Width: 100 ps @ 70 mV p-p.

Internal trigger level range

-1 V to 1 V in 10 mV increments (coarse). Also adjustable in fine increments of 1 mV.

Internal edge trigger slope

Positive

Triggers on rising edge.

Negative

Triggers on falling edge.

Bi-slope

Triggers on both edges of the signal.

*** Internal RMS trigger jitter**

Combined trigger and interpolator jitter

Edge and Divided trigger

2 ps + 0.1 ppm of delay, maximum

Clock recovery trigger (optional)

2 ps + 1.0% of unit interval + 0.1 ppm of delay,
maximum

Internal trigger coupling

DC

5.4.2 External direct trigger

*PicoScope 9402-05, PicoScope 9402-16 only***Trigger style**

Edge

Triggers on a rising and falling edge of any source within frequency range DC to 2.5 GHz.

Divide

The trigger source is divided down four times (/4) before being applied to the trigger system.
Maximum trigger frequency 5 GHz.

Clock recovery (optional)

PicoScope 9402-16: 6.5 Mb/s to 8 Gb/s.
PicoScope 9404L-05: 6.5 Mb/s to 5 Gb/s.

External direct trigger bandwidth and sensitivity	
Low sensitivity	100 mV p-p DC to 100 MHz. Increasing linearly from 100 mV p-p at 100 MHz to 200 mV p-p at 5 GHz. Pulse Width: 100 ps @ 200 mV p-p typical.
* High sensitivity	30 mV p-p DC to 100 MHz. Increasing linearly from 30 mV p-p at 100 MHz to 70 mV p-p at 5 GHz. Pulse Width: 100 ps @ 70 mV p-p.
External direct trigger level range	-1 V to 1 V in 10 mV increments (coarse). Also adjustable in fine increments of 1 mV.
External direct edge trigger slope	
Positive	Triggers on rising edge.
Negative	Triggers on falling edge.
Bi-slope	Triggers on both edges of the signal.
* External direct RMS trigger jitter	Combined trigger and interpolator jitter
Edge and Divided trigger	2 ps + 0.1 ppm of delay, maximum
Clock recovery trigger (optional)	2 ps + 1.0% of unit interval + 0.1 ppm of delay, maximum
External direct trigger coupling	DC

5.4.3 External prescaled trigger

PicoScope 9404-16, PicoScope 9402-16 only

External prescaled trigger coupling	50 Ω, AC coupled, fixed level zero volts
* External prescaled trigger bandwidth and sensitivity	200 mV p-p from 1 GHz to 16 GHz (sine wave input)
* External prescaled RMS trigger jitter	2 ps + 0.1 ppm of delay, maximum. For trigger input slope > 2 V/ns. Combined trigger and interpolator jitter.
Prescaler ratio	Divided by 1 / 2 / 4 / 8, programmable.

External prescaled trigger maximum safe input voltage	PicoScope 9404-16: ± 2 V (DC+peak AC) PicoScope 9402-16: 3 V pk-pk max.
External prescaled trigger input connector	SMA female

5.5 Display

Persistence	
Off	No persistence
Variable Persistence	Time that each data point is retained on the display. Persistence time can be varied from 100 ms to 20 s.
Infinite Persistence	In this mode, a waveform sample point is displayed forever.
Variable Gray Scaling	Five levels of a single color that is varied in saturation and luminosity. Refresh time can be varied from 1 s to 200 s.
Infinite Gray Scaling	
Variable Color Grading	With Color Grading selected, historical timing information is represented by a temperature or spectral color scheme providing "z-axis" information about rapidly changing waveforms. Refresh time can be varied from 1 to 200 s.
Infinite Color Grading	
Style	
Dots	Displays waveforms without persistence, each new waveform record replaces the previously acquired record for a channel.
Vector	This function draws a straight line through the data points on the display. Not suited to multi-value signals such as a displayed eye diagram.
Graticule	Full Grid, Axes with tick marks, Frame with tick marks, Off (no graticule).
Format	

Auto	Automatically places, adds or deletes graticules as you select more or fewer waveforms to display.
Single XT	All waveforms are superimposed and are eight divisions high.
Dual YT	With two graticules, all waveforms can be four divisions high, displayed separately or superimposed.
Quad YT	With four graticules, all waveforms can be two divisions high, displayed separately or superimposed. When you select dual or quad screen display, every waveform channel, memory and function can be placed on a specified graticule.
XY	Displays voltages of two waveforms against each other. The amplitude of the first waveform is plotted on the horizontal X axis and the amplitude of the second waveform is plotted on the vertical Y axis.
XY & YT	Displays both XY and YT pictures. The YT format appears on the upper part of the screen, and the XY format on the lower part of the screen. The YT format display area is one screen and any displayed waveforms are superimposed.
XY + 2YT	Displays both YT and XY pictures. The YT format appears on the upper part of the screen, and the XY format on the lower part of the screen. The YT format display area is divided into two equal screens.
Tandem	Displays graticules to the left and to the right.
Colors	You may choose a default color selection, or select your own color set. Different colors are used for displaying selected items: background, channels, functions, waveform memories, FFTs, TDR/TDTs, and histograms.
Trace annotation	The instrument gives you the ability to add an identifying label, bearing your own text, to a waveform display. For each waveform, you can create multiple labels and turn them all on or all off. Also, you can position them on the waveform by dragging or by specifying an exact horizontal position.

5.6 Save/Recall

Management

Store and recall setups, waveforms and user mask files to any drive on your PC. Storage capacity is limited only by disk space.

File extensions

Waveform files:
 .wfm for binary format,
 .txt for verbose format (text),
 .txty for Y values formats (text).
 Database files: .wdb.
 Setup files: .set.
 User mask files: .pcm.

Operating system

Microsoft Windows® 7, 8 or 10, 32-bit or 64-bit

Waveform save/recall

Up to four waveforms may be stored into the waveform memories (M1 to M4), and then recalled for display.

Save to/recall from disk

You can save or recall your acquired waveforms to or from any drive on the PC. To save a waveform, use the standard Windows **Save As** dialog box. From this dialog box you can create subdirectories and waveform files, or overwrite existing waveform files.

You can load, into one of the Waveform Memories, a file with a waveform you have previously saved and then recall it for display.

Save/recall setups

The instrument can store complete setups in the memory and then recall them.

Screen image

You can copy a screen image into the clipboard with the following formats: Full Screen, Full Window, Client Part, Invert Client Part, Oscilloscope Screen and Oscilloscope Screen.

Autoscale

Pressing the Autoscale key automatically adjusts the vertical channels, the horizontal scale factors, and the trigger level for a display appropriate to the signals applied to the inputs.

The Autoscale feature requires a repetitive signal with a frequency greater than 100 Hz, duty cycle greater than 0.2%, amplitudes greater than 100 mV p-p. Autoscale is operative only for relatively stable input signals.

5.7 Marker

Marker type	X-Marker: vertical bars (measure time). Y-Marker: horizontal bars (measure volts). XY-Markers: waveform markers.
Marker measurements	Absolute, Delta, Volt, Time, Frequency, Slope.
Marker motion	Independent: both markers can be adjusted independently. Paired: both markers can be adjusted together.
Ratiometric measurements	Provide ratiometric measurements between measured and reference values. These measurements give results in such ratiometric units as %, dB, and degrees.

5.8 Measure

Automated measurements	Up to ten simultaneous measurements are supported at the same time.
Automatic parametric	53 automatic measurements available.
Amplitude measurements (17)	Maximum, Minimum, Top, Base, Peak-Peak, Amplitude, Middle, Mean, Cycle Mean, DC RMS, Cycle DC RMS, AC RMS, Cycle AC RMS, Positive Overshoot, Negative Overshoot, Area, Cycle Area.
Timing measurements (18)	Period, Frequency, Positive Width, Negative Width, Rise Time, Fall Time, Positive Duty Cycle, Negative Duty Cycle, Positive Crossing, Negative Crossing, Burst Width, Cycles, Time at Maximum, Time at Minimum, Positive Jitter p-p, Positive Jitter RMS, Negative Jitter p-p, Negative Jitter RMS.
Inter-signal measurements (13)	Delay (8 options), Phase Deg, Phase Rad, Phase %, Gain, Gain dB.
FFT measurements (5)	FFT Magnitude, FFT Delta Magnitude, THD, FFT Frequency, FFT Delta Frequency.
Measurement statistics	Displays current, minimum, maximum, mean and standard deviation on any displayed waveform measurements.
Method of top-base definition	Histogram, Min/Max, or User-Defined (in absolute voltage).

Thresholds	Upper, middle and lower horizontal bars settable in percentage, voltage or divisions. Standard thresholds are 10–50–90% or 20–50–80%.
Margins	Any region of the waveform may be isolated for measurement using left and right margins (vertical bars).
Measurement mode	Repetitive or Single-shot.
Counter	Built-in frequency counter
Source	PicoScope 9404-16: Internal from any of four channels, External Prescaled. PicoScope 9402-16: Internal from any of two channels, External Direct, External Prescaled. PicoScope 9404-05: Internal from any of four channels. PicoScope 9402-05: Internal from any of two channels, External Direct
Resolution	7 digits
Maximum frequency	Internal or External Direct trigger: 5 GHz. External Prescaled trigger: 16 GHz.
Measurement	Frequency, period
Time reference	Internal 250 MHz reference clock

5.9 Mathematics

Waveform math	Up to four math waveforms can be defined and displayed using math functions F1 to F4
Categories and math operators	
Arithmetic	Add, Subtract, Multiply, Divide, Ceil, Floor, Fix, Round, Absolute, Invert, Common, Rescale.
Algebra	Exponentiation (e), Exponentiation (10), Exponentiation (a), Logarithm (e), Logarithm (10), Logarithm (a), Differentiate, Integrate, Square, Square Root, Cube, Power (a), Inverse, Square Root of the Sum.
Trigonometry	Sine, Cosine, Tangent, Cotangent, Arcsine, Arc cosine, Arctangent, Arc cotangent, Hyperbolic Sine, Hyperbolic Cosine, Hyperbolic Tangent, Hyperbolic Cotangent.

FFT	Complex FFT, FFT Magnitude, FFT Phase, FFT Real part, FFT Imaginary part, Complex Inverse FFT, FFT Group Delay.
Bit Operator	AND, NAND, OR, NOR, XOR, XNOR, NOT.
Miscellaneous	Autocorrelation, Correlation, Convolution, Track, Trend, Linear Interpolation, Sin(x)/x Interpolation, Smoothing.
Formula Editor	You can build math waveforms using the Formula Editor control window.
Operands	Any channel, waveform memory, math function, spectrum, or constant can be selected as a source for one of two operands.
FFT	
FFT frequency span	Frequency Span = Sample Rate / 2 = Record Length / (2 × Timebase Range)
FFT frequency resolution	Frequency Resolution = Sample Rate / Record Length
FFT windows	The built-in filters (Rectangular, Hamming, Hann, Flattop, Blackman–Harris and Kaiser–Bessel) allow optimization of frequency resolution, transients, and amplitude accuracy.
FFT measurements	Marker measurements can be made on frequency, delta frequency, magnitude, and delta magnitude. Automated FFT Measurements include: FFT Magnitude, FFT Delta Magnitude, THD, FFT Frequency, and FFT Delta Frequency.

5.10 Histogram

Histogram axis	Vertical, or Horizontal. Both vertical and horizontal histograms, with periodically updated measurements, allow statistical distributions to be analyzed over any region of the signal.
Histogram measurement set	Scale, Offset, Hits in Box, Waveforms, Peak Hits, Pk-Pk, Median, Mean, Standard Deviation, Mean ± 1 Std Dev, Mean ± 2 Std Dev, Mean ± 3 Std Dev, Min, Max-Max, Max.
Histogram window	The histogram window determines which part of the database is used to plot the histogram. You can set the size of the histogram window to be any size that you want within the horizontal and vertical scaling limits of the scope.

5.11 Eye diagram

Eye diagram

PicoScope 9400 Series oscilloscopes can automatically characterize an NRZ and RZ eye pattern. Measurements are based upon statistical analysis of the waveform.

NRZ measurement set

AC RMS, Area, Bit Rate, Bit Time, Crossing %, Crossing Level, Crossing Time, Cycle Area, Duty Cycle Distortion (%), Extinction Ratio (dB, %, ratio), Eye Amplitude, Eye High, Eye High dB, Eye Width (%), Fall Time, Frequency, Jitter (p-p, RMS), Max, Mean, Mid, Min, Negative Overshoot, Noise p-p (One, Zero), Noise RMS (One, Zero), One Level, Peak-Peak, Period, Positive Overshoot, Rise Time, RMS, Signal-to-Noise Ratio, Signal-to-Noise Ratio dB, Zero Level.

RZ measurement set

AC RMS, Area, Bit Rate, Bit Time, Contrast Ratio (dB, %, ratio), Cycle Area, Extinction Ratio (dB, %, ratio), Eye Amplitude, Eye High, Eye High dB, Eye Opening Factor, Eye Width (%), Fall Time, Jitter P-p (Fall, Rise), Jitter RMS (Fall, Rise), Max, Mean, Mid, Min, Negative Crossing, Noise P-p (One, Zero), Noise RMS (One, Zero), One Level, Peak-Peak, Positive Crossing, Positive Duty Cycle, Pulse Symmetry, Pulse Width, Rise Time, RMS, Signal-to-Noise, Zero Level.

5.12 Mask test

Mask test

Acquired signals are tested for fit outside areas defined by up to eight polygons. Any samples that fall within the polygon boundaries result in test failures. Masks can be loaded from disk, or created automatically or manually.

Mask creation

You can create the following Mask: Standard predefined Mask, Automask, Mask saved on disk, Create new mask, Edit any mask.

Standard mask

Standard predefined optical or standard electrical masks can be created.

SONET/SDH

OC1/STMO (51.84 Mb/s)
 OC3/STM1 (155.52 Mb/s)
 OC9/STM3 (466.56 Mb/s)
 OC12/STM4 (622.08 Mb/s)
 OC18/STM6 (933.12 Mb/s)
 OC24/STM8 (1.2442 Gb/s)
 OC48/STM16 (2.48832 Gb/s)

	FEC 2666 (2.6666 Gb/s)
Fibre Channel	FC133 Electrical (132.8 Mb/s) FC133 Optical (132.8 Mb/s) FC266 Electrical (265.6 Mb/s) FC266 Optical (265.6 Mb/s) FC531 Electrical (531.35 Mb/s) FC531 Optical (531.35 Mb/s) FC1063 Electrical (1.0625 Gb/s) FC1063 Optical (1.0625 Gb/s) FC1063 Optical PI Rev13 (1.0625 Gb/s) FC1063E Abs Beta Rx.mask (1.0625 Gb/s) FC1063E Abs Beta Tx.mask (1.0625 Gb/s) FC1063E Abs Delta Rx.mask (1.0625 Gb/s) FC1063E Abs Delta Tx.mask (1.0625 Gb/s) FC1063E Abs Gamma Rx.mask (1.0625 Gb/s) FC1063E Abs Gamma Tx.mask (1.0625 Gb/s) FC2125 Optical (2.1231 Gb/s) FC2125 Optical PI Rev13 (2.1231 Gb/s) FC2125E Abs Beta Rx.mask (2.125 Gb/s) FC2125E Abs Beta Tx.mask (2.125 Gb/s) FC2125E Abs Delta Rx.mask (2.125 Gb/s) FC2125E Abs Delta Tx.mask (2.125 Gb/s) FC2125E Abs Gamma Rx.mask (2.125 Gb/s) FC2125E Abs Gamma Tx.mask (2.125 Gb/s) PicoScope 9404-16, PicoScope 9402-16 only: FC4250 Optical PI Rev13 (4.25 Gb/s) FC4250E Abs Beta Rx.mask (4.25 Gb/s) FC4250E Abs Beta Tx.mask (4.25 Gb/s) FC4250E Abs Delta Rx.mask (4.25 Gb/s) FC4250E Abs Delta Tx.mask (4.25 Gb/s) FC4250E Abs Gamma Rx.mask (4.25 Gb/s) FC4250E Abs Gamma Tx.mask (4.25 Gb/s)
Ethernet	100BASE-BX10 (125 Mb/s) 100BASE-BX/LX10 (125 Mb/s) 1.25 Gb/s 1000Base-CX Absolute TP2 (1.25 Gb/s) 1.25 Gb/s 1000Base-CX Absolute TP3 (1.25 Gb/s) GB Ethernet (1.25 Gb/s) 2XGB Ethernet (2.5 Gb/s) 3.125 Gb/s 10GBase-CX4 Absolute TP2 (3.125 Gb/s)
Infiniband	2.5G InfiniBand Cable mask (2.5 Gb/s) 2.5G InfiniBand Driver Test Point 1 (2.5 Gb/s) 2.5G InfiniBand Driver Test Point 10 (2.5 Gb/s) 2.5G InfiniBand Driver Test Point 2 (2.5 Gb/s) 2.5G InfiniBand Driver Test Point 3 (2.5 Gb/s) 2.5G InfiniBand Driver Test Point 4 (2.5 Gb/s) 2.5G InfiniBand Driver Test Point 5 (2.5 Gb/s) 2.5G InfiniBand Driver Test Point 6 (2.5 Gb/s) 2.5G InfiniBand Driver Test Point 7 (2.5 Gb/s) 2.5G InfiniBand Driver Test Point 8 (2.5 Gb/s) 2.5G InfiniBand Driver Test Point 9 (2.5 Gb/s) 2.5G InfiniBand Receiver mask (2.5 Gb/s)

	<p>InfiniBand (2.5 Gb/s)</p> <p>PicoScope 9404-16, PicoScope 9402-16 only:</p> <p>5.0G InfiniBand Driver Test Point 1 (5 Gb/s)</p> <p>5.0G InfiniBand Driver Test Point 6 (5 Gb/s)</p> <p>5.0G InfiniBand Transmitter Pins (5 Gb/s)</p>
XAUI	<p>3.125 Gb/s XAUI Far End (3.125 Gb/s)</p> <p>3.125 Gb/s XAUI Far End (3.125 Gb/s)</p> <p>XAUI-E Far (3.125 Gb/s)</p> <p>XAUI-E Near (3.125 Gb/s)</p>
ITU G.703	<p>DS1, 100 Û twisted pair (1.544 Mb/s)</p> <p>2 Mb 120, 120 Û twisted pair (2.048 Mb/s)</p> <p>2 Mb 75, 75 Û coax (2.048 Mb/s)</p> <p>DS2 110, 110 Û twisted pair (6.312 Mb/s)</p> <p>DS2 75, 75 Û coax (6.312 Mb/s)</p> <p>8 Mb, 75 Û coax (8.448 Mb/s)</p> <p>34 Mb, 75 Û coax (34.368 Mb/s)</p> <p>DS3, 75 Û coax (44.736 Mb/s)</p> <p>140 Mb 0, 75 Û coax (139.264 Mb/s)</p> <p>140 Mb 1, 75 Û coax (139.264 Mb/s)</p> <p>140 Mb 1 Inv, 75 Û coax (139.264 Mb/s)</p> <p>155 Mb 0, 75 Û coax (155.520 Mb/s)</p> <p>155 Mb 1, 75 Û coax (155.520 Mb/s)</p> <p>155 Mb 1 Inv, 75 Û coax (155.520 Mb/s)</p>
ANSI T1/102	<p>DS1, 100 Û twisted pair, (1.544 Mb/s)</p> <p>DS1C, 100 Û twisted pair, (3.152 Mb/s)</p> <p>DS2, 110 Û twisted pair, (6.312 Mb/s)</p> <p>DS3, 75 Û coax, (44.736 Mb/s)</p> <p>STS1 Eye, 75 Û coax, (51.84 Mb/s)</p> <p>STS1 Pulse, 75 Û coax, (51.84 Mb/s)</p> <p>STS3, 75 Û coax, (155.520 Mb/s)</p>
RapidIO	<p>RapidIO Serial Level 1, 1.25G Rx (1.25 Gb/s)</p> <p>RapidIO Serial Level 1, 1.25G Tx LR (1.25 Gb/s)</p> <p>RapidIO Serial Level 1, 1.25G Tx SR (1.25 Gb/s)</p> <p>RapidIO Serial Level 1, 2.5G Rx (2.5 Gb/s)</p> <p>RapidIO Serial Level 1, 2.5G Tx LR (2.5 Gb/s)</p> <p>RapidIO Serial Level 1, 2.5G Tx SR (2.5 Gb/s)</p> <p>RapidIO Serial Level 1, 3.125G Rx (3.125 Gb/s)</p> <p>RapidIO Serial Level 1, 3.125G Tx LR (3.125 Gb/s)</p> <p>RapidIO Serial Level 1, 3.125G Tx SR (3.125 Gb/s)</p>
PCI Express	<p>R1.0a 2.5G Add-in Card Transmitter Non-Transition bit mask (2.5 Gb/s)</p> <p>R1.0a 2.5G Add-in Card Transmitter Transition bit mask (2.5 Gb/s)</p> <p>R1.0a 2.5G Exp.Card Host Non-Transition bit mask (2.5 Gb/s)</p> <p>R1.0a 2.5G Exp.Card Host Transition bit mask (2.5 Gb/s)</p> <p>R1.0a 2.5G Exp.Card Module Non-Transition bit mask (2.5 Gb/s)</p>

R1.0a 2.5G Exp.Card Module Transition bit mask (2.5 Gb/s)
R1.0a 2.5G Exp.Card Transmitter Non-Transition bit mask (2.5 Gb/s)
R1.0a 2.5G Exp.Card Transmitter Transition bit mask (2.5 Gb/s)
R1.0a 2.5G Mobile Transmitter bit mask (2.5 Gb/s)
R1.0a 2.5G Receiver mask (2.5 Gb/s)
R1.0a 2.5G System Board Transmitter Non-Transition bit mask (2.5 Gb/s)
R1.0a 2.5G System Board Transmitter Transition bit mask (2.5 Gb/s)
R1.0a 2.5G Transmitter Non-Transition bit mask (2.5 Gb/s)
R1.0a 2.5G Transmitter Transition bit mask (2.5 Gb/s)
R1.1 2.5G Add-in Card Transmitter Non-Transition bit mask (2.5 Gb/s)
R1.1 2.5G Add-in Card Transmitter Transition bit mask (2.5 Gb/s)
R1.1 2.5G Cable Receiver End Non-Transition bit mask (2.5 Gb/s)
R1.1 2.5G Cable Receiver End Transition bit mask (2.5 Gb/s)
R1.1 2.5G Cable Transmitter End Non-Transition bit mask (2.5 Gb/s)
R1.1 2.5G Cable Transmitter End Transition bit mask (2.5 Gb/s)
R1.1 2.5G Express Module System Non-Transition bit mask (2.5 Gb/s)
R1.1 2.5G Express Module System Transition bit mask (2.5 Gb/s)
R1.1 2.5G Express Module Transmitter Path Non-Transition bit mask (2.5 Gb/s)
R1.1 2.5G Express Module Transmitter Path Transition bit mask (2.5 Gb/s)
R1.1 2.5G Receiver mask (2.5 Gb/s)
R1.1 2.5G System Board Transmitter Non-Transition bit mask (2.5 Gb/s)
R1.1 2.5G System Board Transmitter Transition bit mask (2.5 Gb/s)
R1.1 2.5G Transmitter Non-Transition bit mask (2.5 Gb/s)
R1.1 2.5G Transmitter Transition bit mask (2.5 Gb/s)
PicoScope 9404-16, PicoScope 9402-16 only:
R2.0 5.0G Add-in Card 35 dB Transmitter Non-Transition bit mask (5 Gb/s)
R2.0 5.0G Add-in Card 60 dB Transmitter Non-Transition bit mask (5 Gb/s)
R2.0 5.0G Add-in Card 35 dB Transmitter Transition bit mask (5 Gb/s)
R2.0 5.0G Add-in Card 60 dB Transmitter Transition bit mask (5 Gb/s)
R2.0 5.0G Mobile Transmitter mask (5 Gb/s)

	<p>R2.0 5.0G Receiver mask (5 Gb/s) R2.0 5.0G System Board Transmitter Non-Transition bit mask (5 Gb/s) R2.0 5.0G System Board Transmitter Transition bit mask (5 Gb/s) R2.0 5.0G Transmitter Non-Transition bit mask (5 Gb/s) R2.0 5.0G Transmitter Transition bit mask (5 Gb/s) R2.1 5.0G Transmitter Non-Transition bit mask (5 Gb/s) R2.1 5.0G Transmitter Transition bit mask (5 Gb/s)</p>
Serial ATA	<p>Ext Length, 1.5G 250 Cycle, Rx Mask (1.5 Gb/s) Ext Length, 1.5G 250 Cycle, Tx Mask (1.5 Gb/s) Ext Length, 1.5G 5 Cycle, Rx Mask (1.5 Gb/s) Ext Length, 1.5G 5 Cycle, Tx Mask (1.5 Gb/s) Gen1, 1.5G 250 Cycle, Rx Mask (1.5 Gb/s) Gen1, 1.5G 250 Cycle, Tx Mask (1.5 Gb/s) Gen1, 1.5G 5 Cycle, Rx Mask (1.5 Gb/s) Gen1, 1.5G 5 Cycle, Tx Mask (1.5 Gb/s) Gen1m, 1.5G 250 Cycle, Rx Mask (1.5 Gb/s) Gen1m, 1.5G 250 Cycle, Tx Mask (1.5 Gb/s) Gen1m, 1.5G 5 Cycle, Rx Mask (1.5 Gb/s) Gen1m, 1.5G 5 Cycle, Tx Mask (1.5 Gb/s) Ext Length, 3.0G 250 Cycle, Rx Mask (3 Gb/s) Ext Length, 3.0G 250 Cycle, Tx Mask (3 Gb/s) Ext Length, 3.0G 5 Cycle, Rx Mask (3 Gb/s) Ext Length, 3.0G 5 Cycle, Tx Mask (3 Gb/s) Gen1, 3.0G 250 Cycle, Rx Mask (3 Gb/s) Gen1, 3.0G 250 Cycle, Tx Mask (3 Gb/s) Gen1, 3.0G 5 Cycle, Rx Mask (3 Gb/s) Gen1, 3.0G 5 Cycle, Tx Mask (3 Gb/s) Gen1m, 3.0G 250 Cycle, Rx Mask (3 Gb/s) Gen1m, 3.0G 250 Cycle, Tx Mask (3 Gb/s) Gen1m, 3.0G 5 Cycle, Rx Mask (3 Gb/s) Gen1m, 3.0G 5 Cycle, Tx Mask (3 Gb/s)</p>
Mask margin	Available for industry-standard mask testing
Automask creation	Masks are created automatically for single-valued voltage signals. Automask specifies both delta X and delta Y tolerances. The failure actions are identical to those of limit testing.
Data collected during test	Total number of waveforms examined, number of failed samples, number of hits within each polygon boundary

5.13 Inputs/outputs

Calibrator output

PicoScope 9404-16, PicoScope 9404-05 only

Calibrator output mode	DC, 1 kHz square, meander (variable-frequency square wave) with frequency from 15.266 Hz to 500 kHz.
Output DC level	Adjustable from -1 V to +1 V into 50 Ω. Coarse increment: 50 mV, fine increment: 1 mV.
* Output DC level accuracy	± 1 mV ± 0.5% of output DC level
Output impedance	50 Ω nominal
Rise/Fall time	150 ns, typical
Output connectors	SMA female
Trigger output	PicoScope 9404-16, PicoScope 9404-05 only
Timing	Positive transition equivalent to acquisition trigger point
Low level	(-0.2 ± 0.1) V. Measured into 50 Ω.
Amplitude	(900 ± 200) mV. Measured into 50 Ω.
Rise time	10% to 90%: ≤ 0.45 ns. 20% to 80%: ≤ 0.3 ns.
RMS jitter	2 ps or less
Output delay	(4 ± 1) ns
Output coupling	DC-coupled
Output connectors	SMA female
Clock recovery Data output (optional)	
Data Rate	PicoScope 9404-16, PicoScope 9402-16: 6.5 Mb/s to 8 Gb/s. PicoScope 9404-05, PicoScope 9402-05: 6.5 Mb/s to 5 Gb/s.
Eye amplitude	250 mV p-p, typical
Eye rise/fall time	PicoScope 9404-16: 20%–80%: 50 ps, typical. Measured at PicoScope 9404-16. PicoScope 9402-16: 20%–80%: 50 ps, typical. Measured at PicoScope 9402-16.

	PicoScope 9404-05: 20%–80%: 75 ps, typical. Measured at PicoScope 9404-05. PicoScope 9402-05: 20%–80%: 75 ps, typical. Measured at PicoScope 9402-05.
RMS jitter	2 ps + 1% of unit interval
Output coupling	AC-coupled
Output connector	SMA female
Clock recovery Clock output (optional)	
Output frequency	Half full rate clock output. PicoScope 9404-16, PicoScope 9402-16: 3.25 MHz to 4 GHz. PicoScope 9404-05, PicoScope 9402-05: 3.25 MHz to 2.5 GHz.
Amplitude	250 mV p-p, typical
Output coupling	AC-coupled
Output connector	SMA female

5.14 Power requirement

Power supply voltage	+12 V ± 5%
Power supply current	PicoScope 9404-16: 2.7 A max (no accessories) PicoScope 9404-05: 2.6 A max (no accessories) Both models: 3.3 A max. including active accessories. PicoScope 9402-16, PicoScope 9402-05: 1.8 A max.
Protection	Auto shutdown on excess or reverse voltage
AC-DC adaptor	Universal adaptor supplied

5.15 PC connection

PC connection	PicoScope 9404-16, PicoScope 9402-16, PicoScope 9404-05, PicoScope 9402-05: USB 2.0 (high speed). Also compatible with USB 3.0. PicoScope 9404-16, PicoScope 9404-05: LAN.
----------------------	---

5.16 Physical characteristics

Dimensions

PicoScope 9404-16, PicoScope 9404-05: Width: 245 mm,
Height: 60 mm, Depth: 232 mm.
PicoScope 9402-16, PicoScope 9402-05: Width: 160 mm, Height: 55 mm, Depth: 220 mm.

Net weight

PicoScope 9404-16, PicoScope 9404-05: 1.4 kg
PicoScope 9402-16, PicoScope 9402-05: 800 g

5.17 Environmental conditions

Temperature

Operating, normal: +5 °C to +40 °C
Operating, for quoted accuracy: +15 °C to +25 °C
Storage: -20 °C to +50 °C

Humidity

Operating: Up to 85 % relative humidity
(non-condensing) at +25 °C
Storage: Up to 95 % relative humidity
(non-condensing)

6 PicoSample 4 software

The PicoSample 4 user interface provides access to commands that control all of the instrument features and functions.

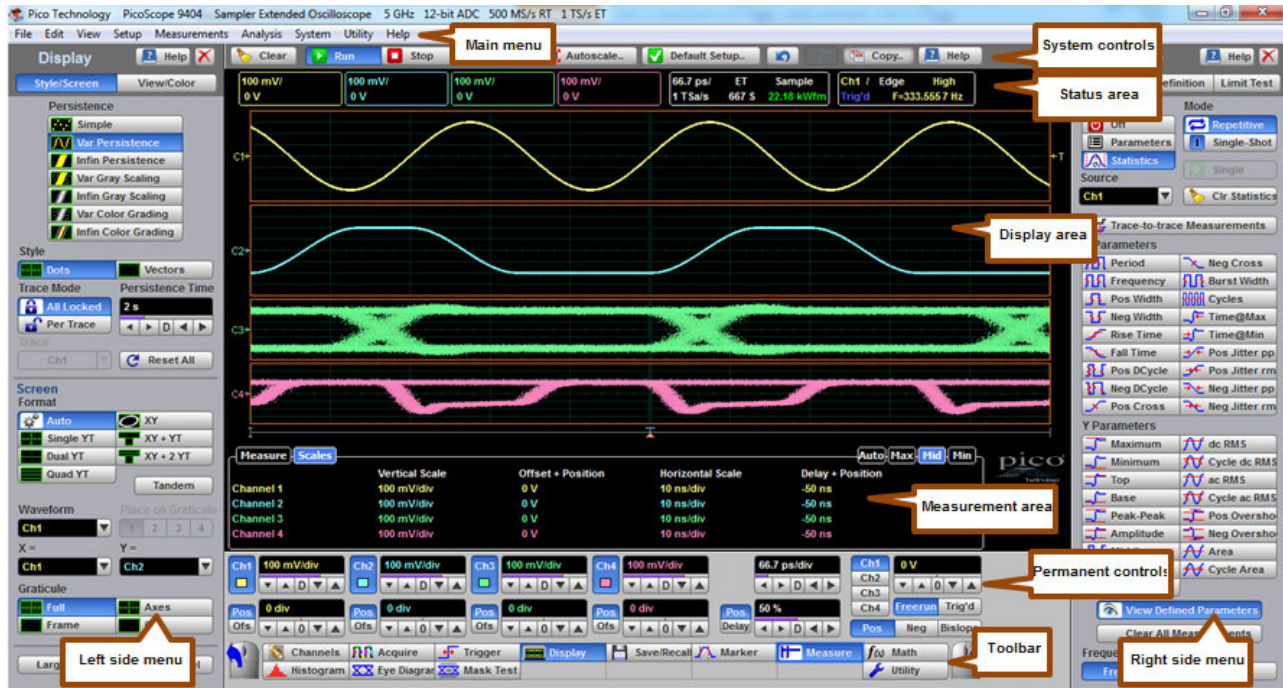

Areas of the PicoSample 4 GUI

6.1 Demo mode

If you start PicoSample 4 without a device connected, you have the option to use a demonstration waveform. Click **Demo** on the **Initialisation...** dialog.

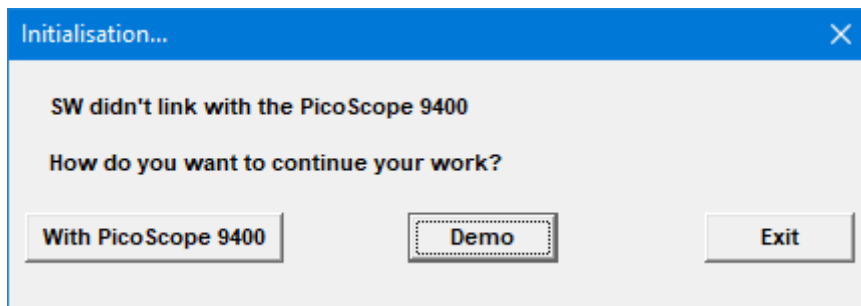

Initialization... dialog

By default, the software will emulate the PicoScope 9404-05. The model can be changed through the [Help](#) control. See [System Controls - Help](#) for more information.

You can adjust all of the characteristics of the demonstration waveform displayed using the functions in the **Utility** menu. See [Utility Menu - Demo](#) for further information.

6.2 Display area

The following functions are concerned with **Display Area**:

- Live, reference, and math waveforms display here, along with cursors.
- You can drag the waveform to reposition it.
- You can drag across the waveform area to create a box for zooming.
- You can drag the **T** icon to change the trigger level for the selected trigger source.
- You can drag markers to measure waveforms on screen.

6.3 Drag and zoom

You can use the mouse to change the vertical scale and offset, and also the horizontal scale and delay for all input channels, waveform memories, or waveform math functions that are currently displayed. Do this by holding down the left mouse button and moving the cursor until the zoom box covers the area of interest. To zoom, release the left mouse button and select a function from the menu. The PicoScope 9400 will change the vertical scale and vertical offset and it will change the horizontal scale and horizontal position for all displayed waveforms.

You can cancel the zoom operation by clicking anywhere outside of the zoom box. You can undo the zoom operation by clicking the [Undo](#)  button.

You can also change the vertical offset on individual channels, waveform memories, or waveform math functions by clicking and dragging the waveform or by clicking and dragging the ground marker.

You can change the delay on displayed waveforms by clicking on the waveform and dragging it left or right.

Each channel has its own **Ground Reference Indicator**  located to the left of the graticule area. The **Ground Reference Indicator** shows you where zero volts is for each channel. The default marker position is mid-screen. During an **Autoscale**, an offset is applied to vertically center the signal.

6.4 Main menu

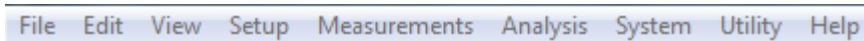

The **Main Menu** provides access to commands that control all of the instrument features and functions. When you select a feature setup command, the instrument displays the associated side menus, most of which can also be accessed from the [Toolbar](#).

6.4.1 File

The **File** menu includes the following controls:

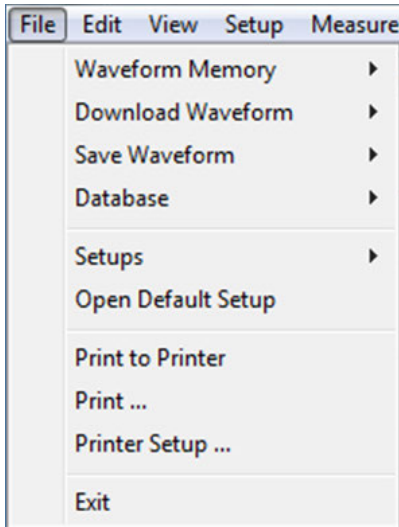

The **Waveform Memory** submenu recalls or clears the M1–M4 waveform memories. This submenu includes the following controls:

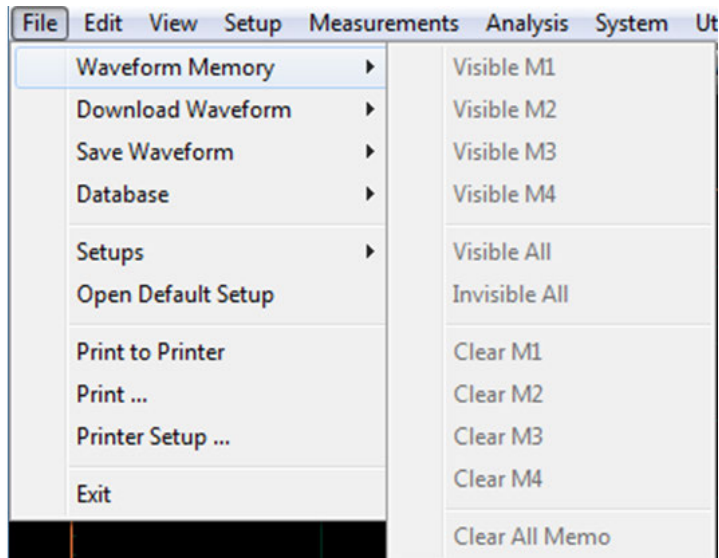

The **Download Waveform** submenu loads the selected file from a disk into one of the memories M1–M4. This submenu includes the following controls:

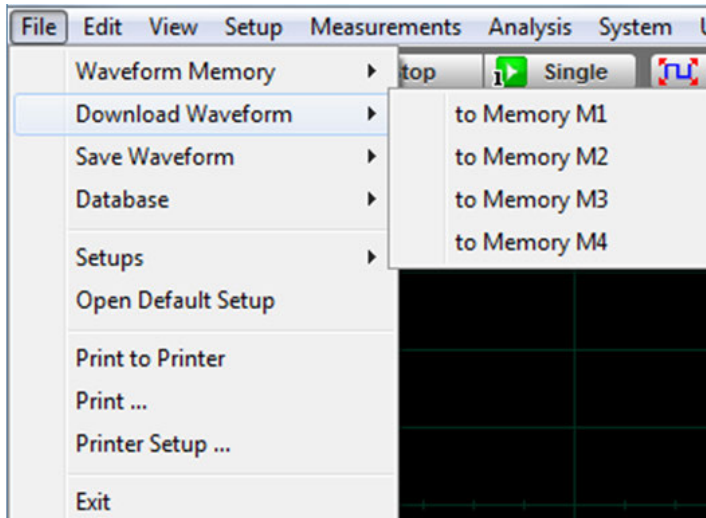

The **Save Waveform** submenu saves the waveform from the selected source (channel Ch1-Ch4, function F1-F4 or waveform memory M1-M4) to the selected waveform memory (M1-M4), disk or database. This submenu includes the following controls:

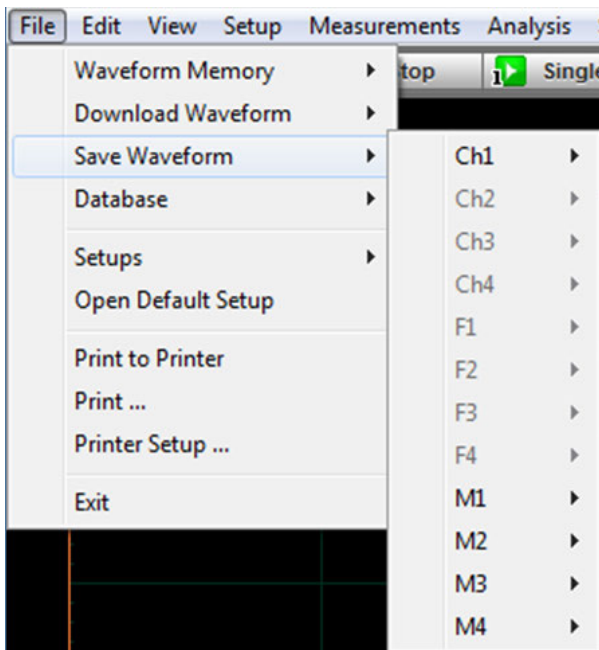

The **Database** submenu downloads, recalls or clears the waveform database. This database consists of all data samples displayed on the screen when the **Display Style** is set to persistence, gray scaling or color grading. It provides the data for the construction of histograms and performing mask tests. This submenu includes the following controls:

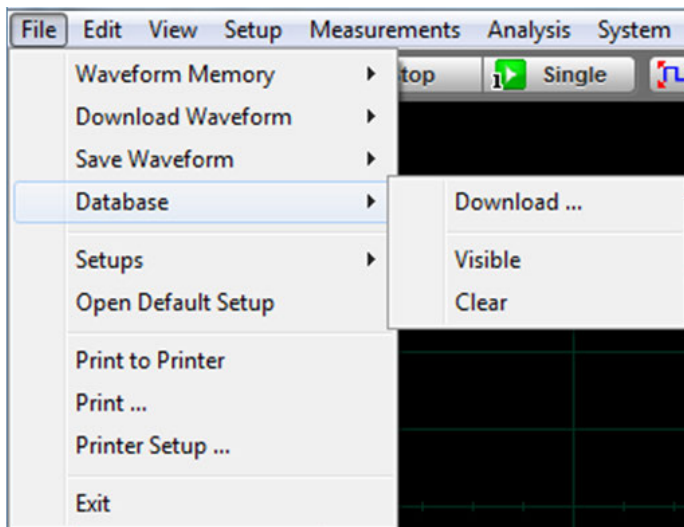

Download... opens the Windows **Load Database** dialog and allows you to select a database file to recall from disk to Database Memory (**DB**).

Visible makes the waveform database visible or invisible.

Clear removes the selected database file from the waveform database.

The **Setup** submenu allows you to save and open (recall) setup. This submenu includes the following controls:

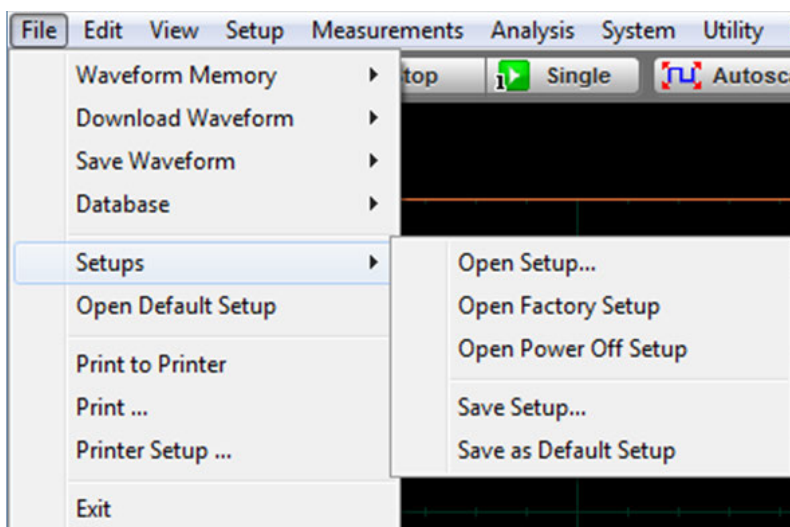

You can use the setup memories when you want to:

- **Open Setup:** you can recall a setup that you have previously saved on any drive of your PC.
- **Open Factory Setup:** returns the instrument to the manufacturer's default setting. This places the oscilloscope in a known operating condition. You may find it helpful to use the default factory settings when initially setting up the instrument to view signals, or when someone else has used the scope before you. You may also use the default settings to troubleshoot unexpected instrument behavior.
- **Open Power Off Setup:** returns the instrument to the last setting before the power supply was last switched off.
- **Save Setup:** stores the present front-panel setup to a selected setup memory. To save a current setup for later use, you can use any available drive. Use the standard Windows **Setup Files** dialog box. You can create subdirectories or new setup files, or overwrite existing setup files from this dialog box. The PicoScope 9400 uses the file extension **.set** for setup files.
- **Save as Default:** stores the present front-panel setup as the default setup.

The **Open Default Setup** command returns the instrument to its default settings. This places the oscilloscope in a known operating condition.

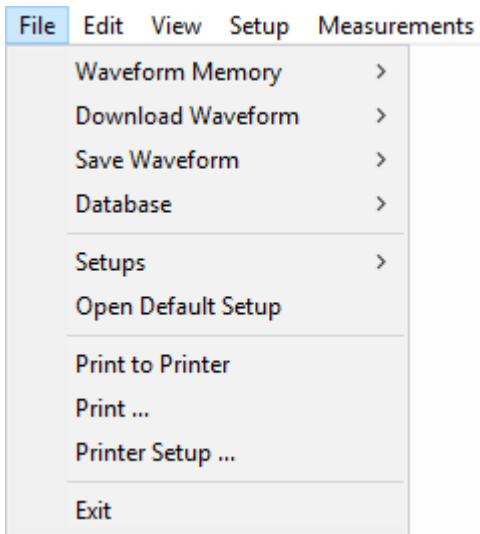

You may find it helpful to use this known operating condition when someone else has used the oscilloscope before you. If you accidentally press **Open Default Setup**, use **Undo**  to return the oscilloscope to the operating condition it was in before **Open Default Setup** was pressed.

The **Print...** submenu allows you to select different printer options. This submenu includes the following controls:

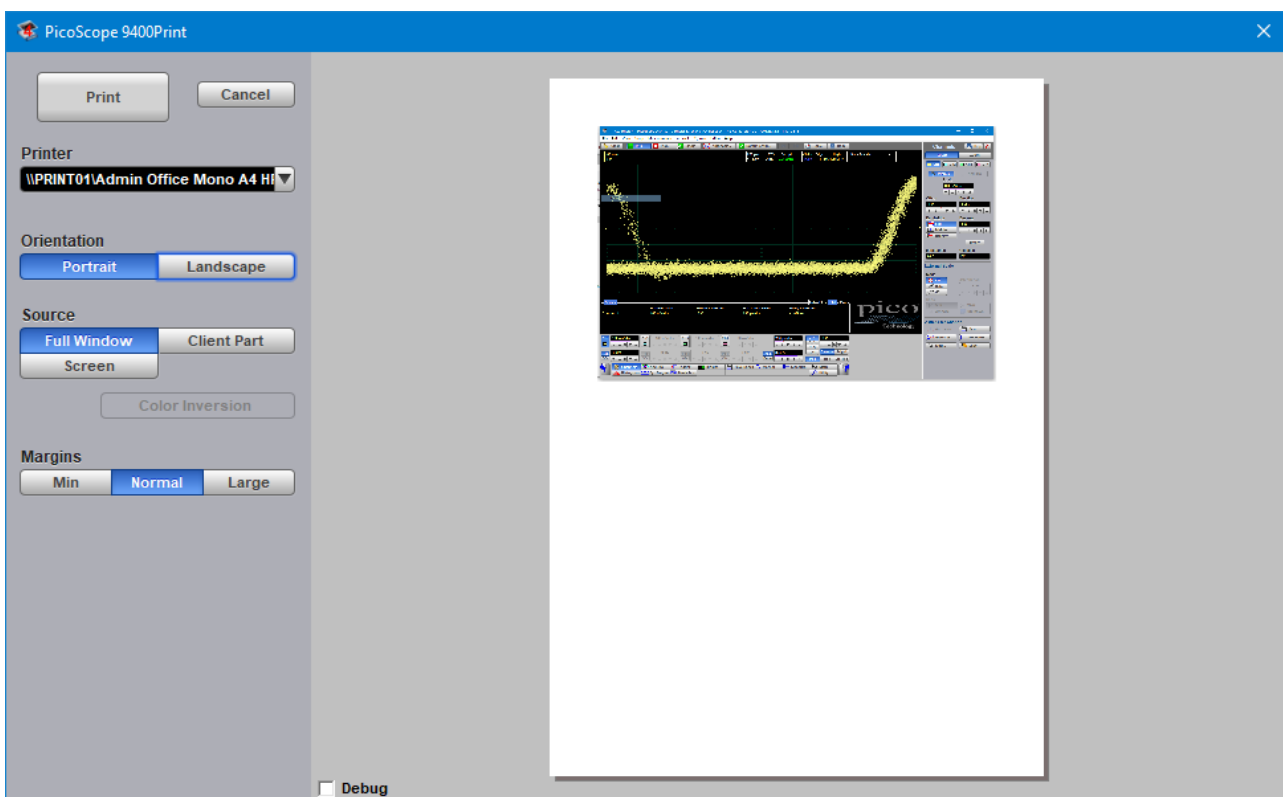

- **Print:** prints the output file
- **Cancel:** cancels printing of the file
- **Printer:** selects the printer you want to use
- **Orientation:** selects page orientation for printing: **Portrait** or **Landscape**.

- **Invert Colors:** this mode is used for better printing of the waveforms on white paper, and greatly reduces the usage of toner.
- **Margins:** defines the margins when printing: **Min**, **Normal** or **Large**.

Printer Setup... is a standard Windows Print Setup dialog:

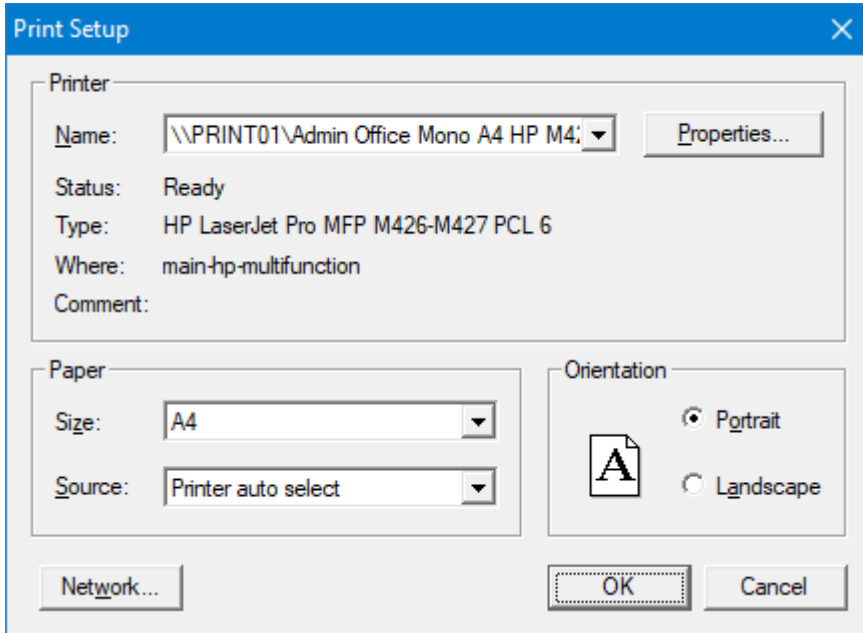

The **Exit** command closes PicoSample 4:

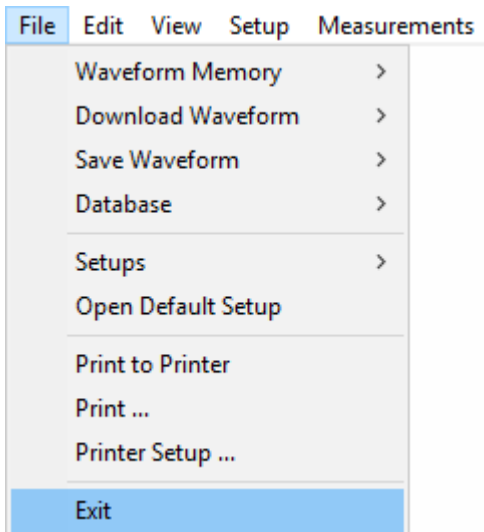

6.4.2 Edit

The **Edit** menu includes the following controls:

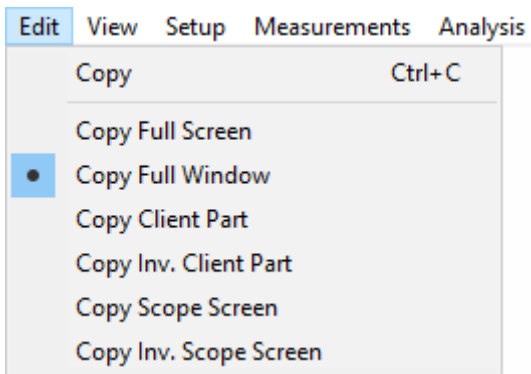

This menu allows you to copy different programming windows to the **Windows Clipboard**. From there, you can paste copied information into such **Windows** programs as **Word**, **Corel Draw**, **Paintbrush** and **Photoshop**.

Use the **Copy** functions when preparing documentation based on usage of the PicoScope 9400.

6.4.3 View

The **View** menu allows you to configure various components of the display. It assigns the following items to different parts of the display:

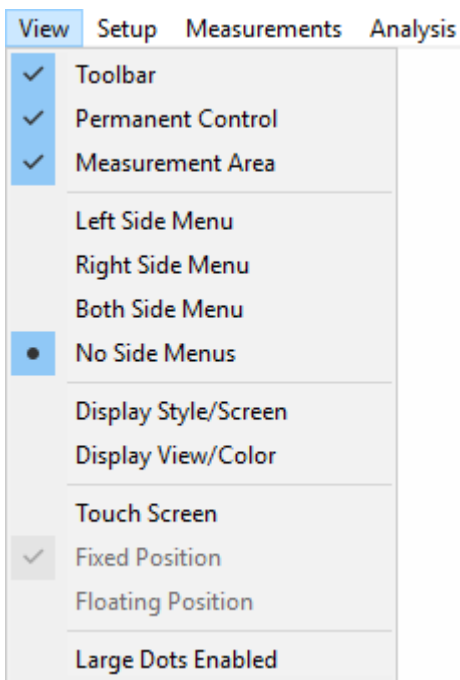

Below are shown several different options from the **View** menu:

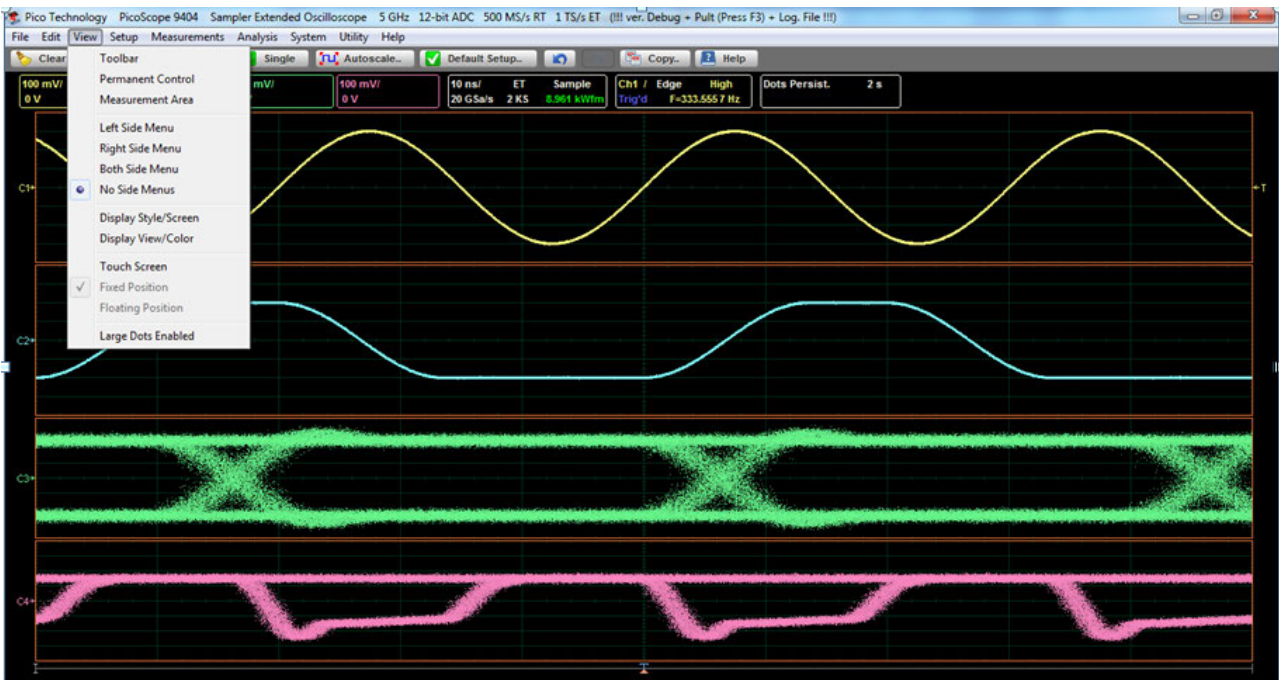

1. All options of the View menu are turned off

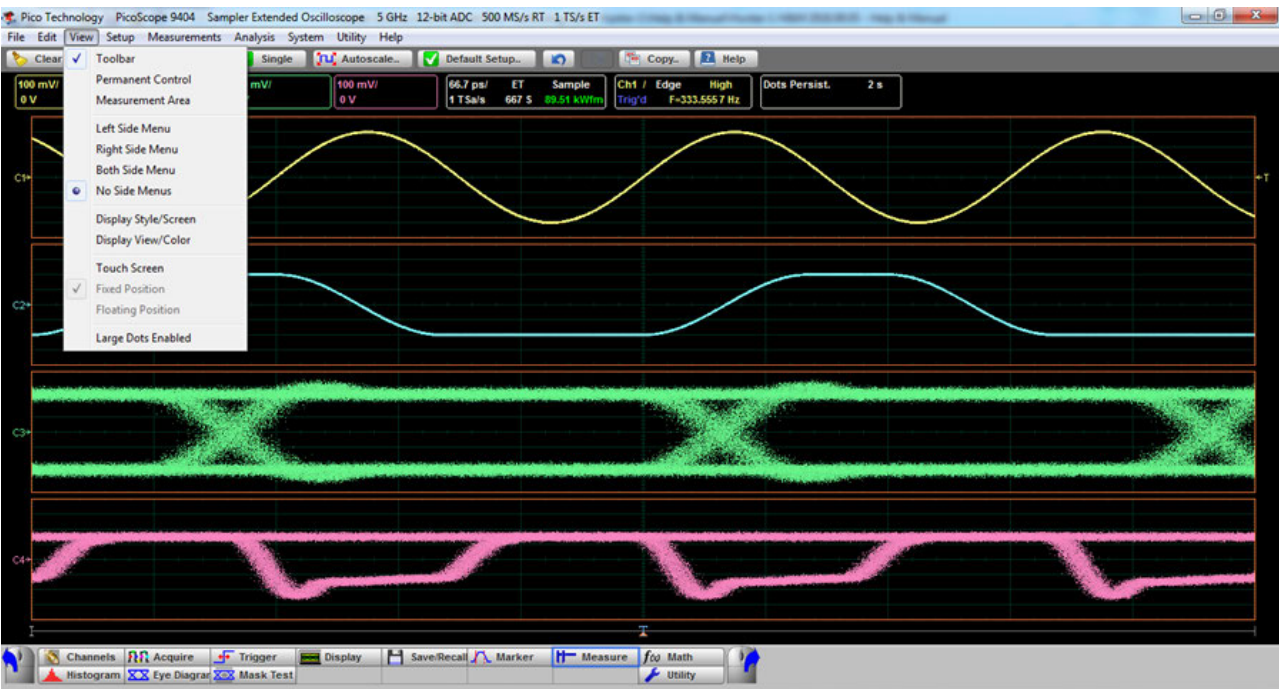

2. Toolbar is added

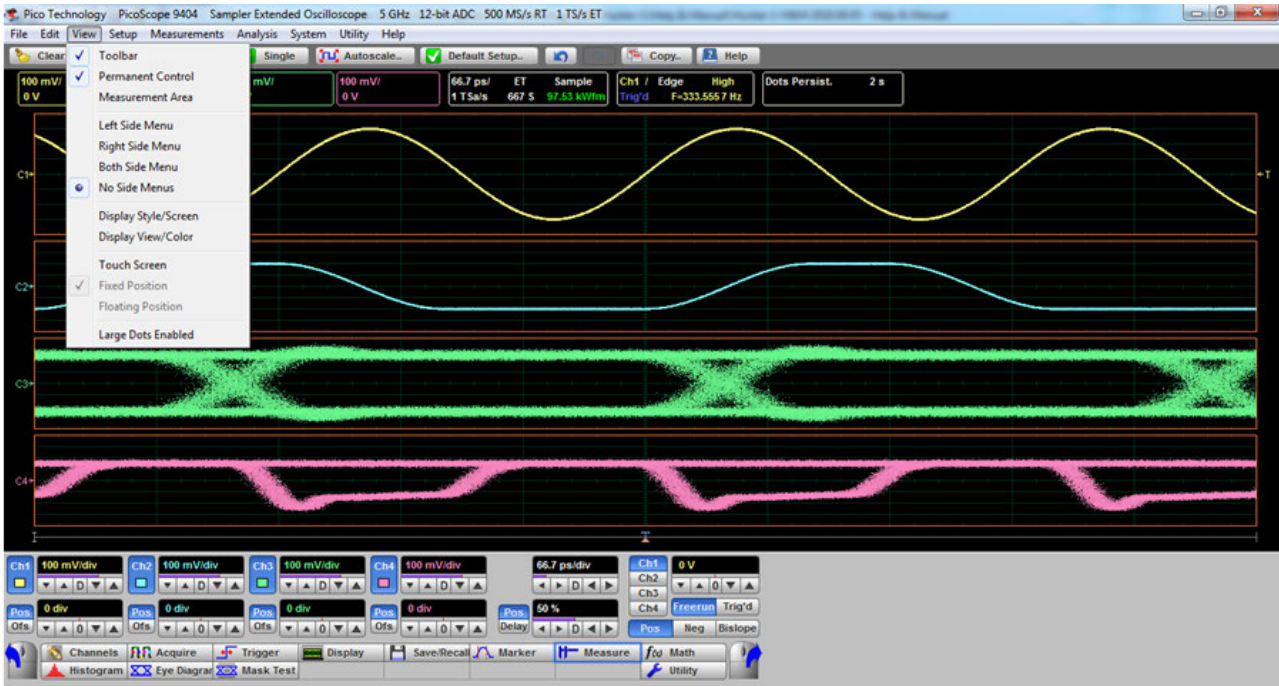

3. Permanent Control is added

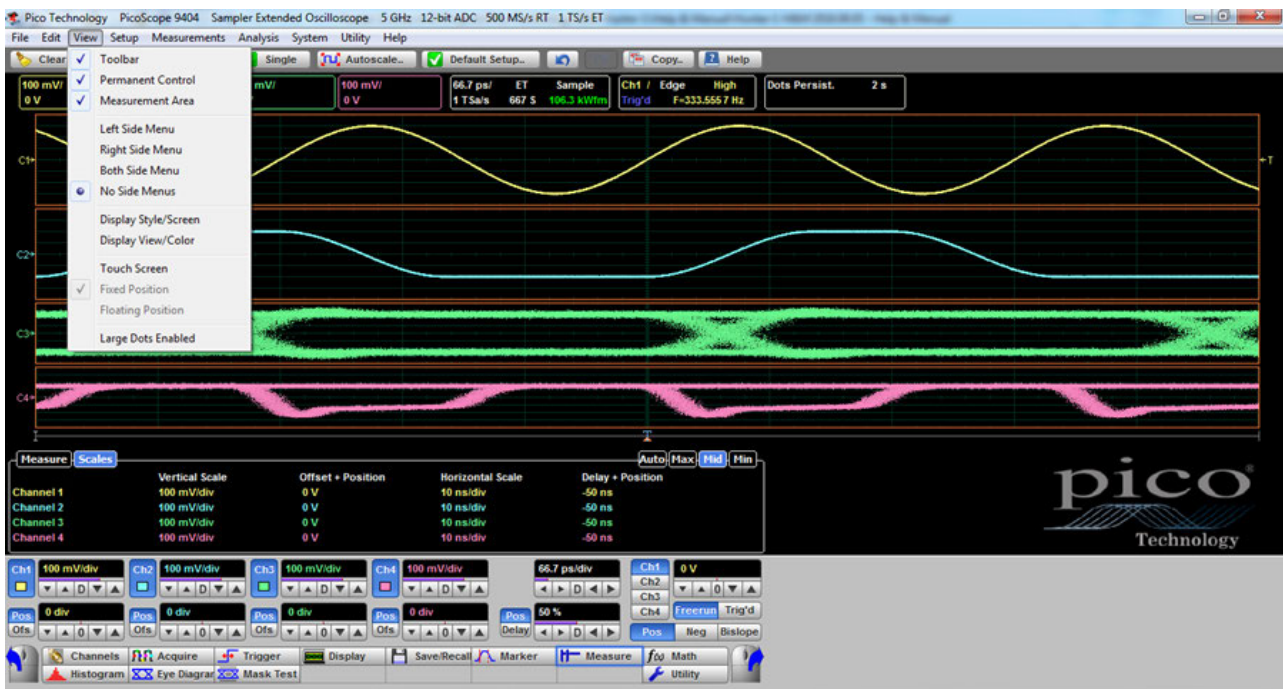

4. Measurement area is added

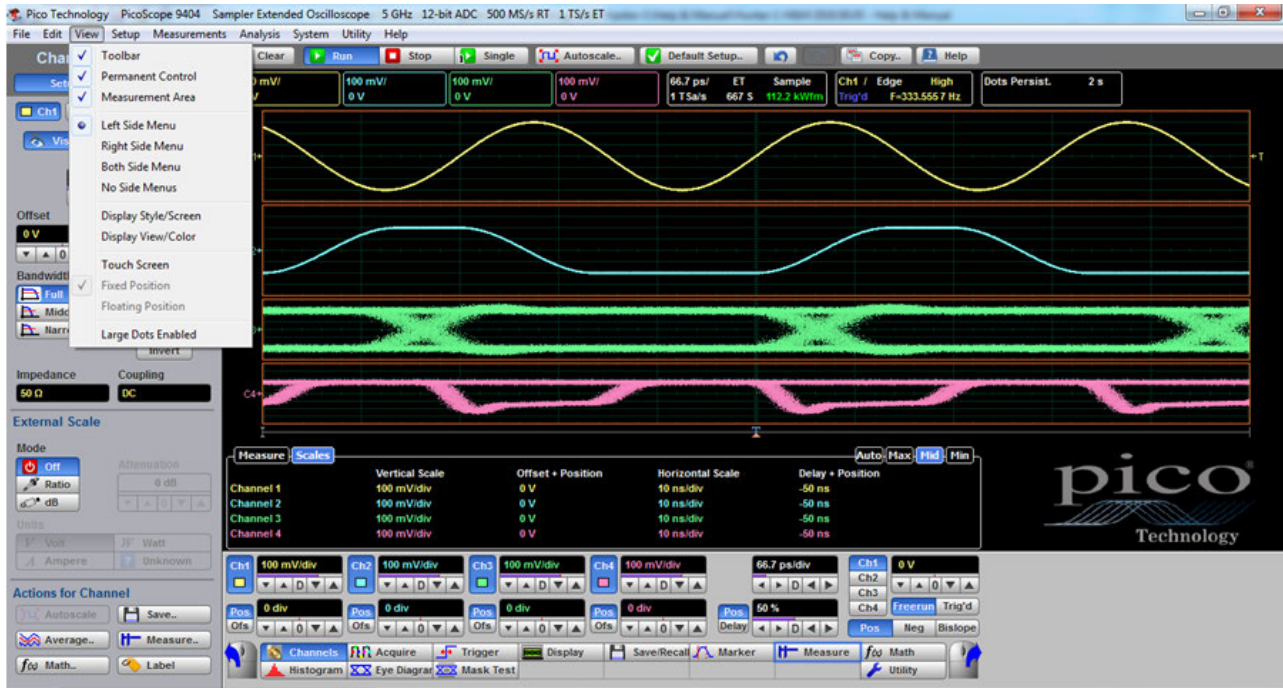

5. Left Side Menu is added

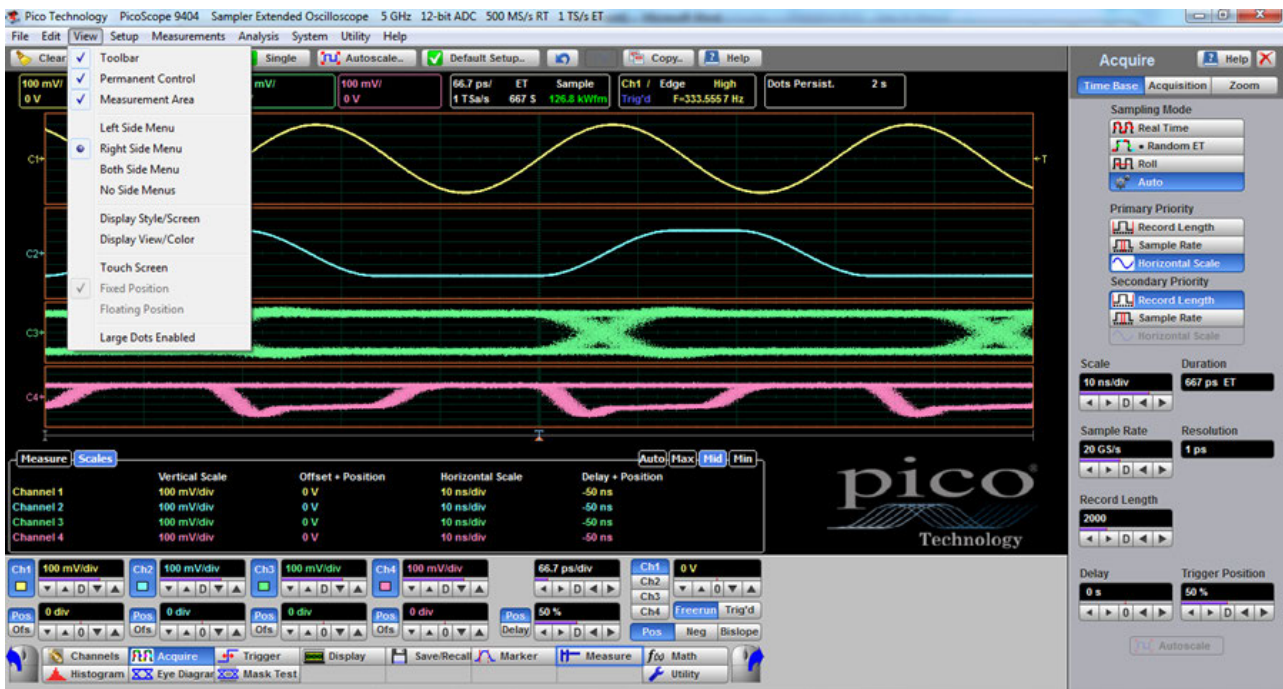

6. Right Side Menu is added

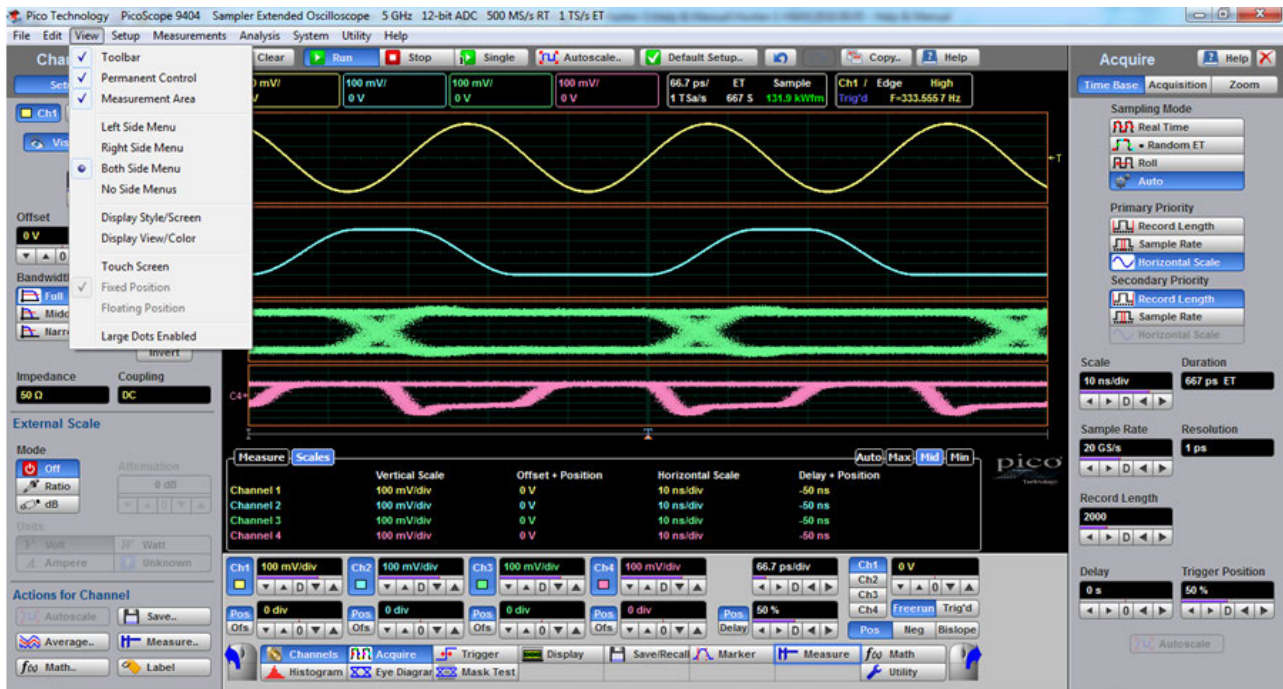

7. Both Side Menus are added

6.4.3.1 Touchscreen settings

When **View > Touchscreen** is checked, PicoSample 4 displays a larger, touchscreen-friendly keypad whenever you click a numerical control. For example, when you click the **Trigger Level** control in this mode, and when **Floating Position** is also checked, the following repositionable keypad is displayed:



If, instead of **Floating Position**, **Fixed Position** is checked, the keypad appears to the right of the [permanent controls](#) and cannot be moved. The permanent controls must be displayed for this option to work.

Other touchscreen-friendly actions, such as drawing a zoom box over the waveform, are always available regardless of the state of the **View > Touchscreen** setting.

6.4.4 Setup

The **Setup** menu assigns the following items to the side menu:

- Channel 1
- Channel 2
- Channel 3
- Channel 4
- Time Base/Acquisition
- Edge Trigger
- Advanced Trigger

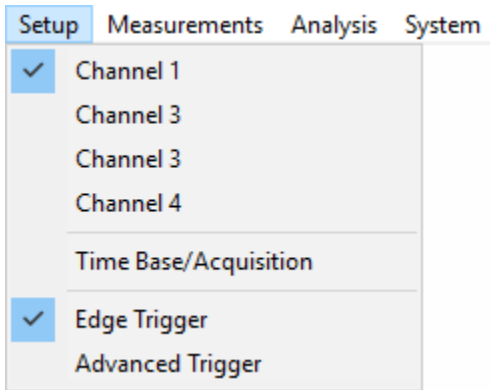

The **Setup** menu assigns the item to the left side menu if it is opened or if both side menus are opened.

The **Setup** menu assigns the item to the right side menu if only right side menu is opened.

6.4.5 Measurements

The **Measurements** menu assigns the following items to the side menu:

- **Marker**
- **Measure**
- **Histogram**
- **Eye Diagram**

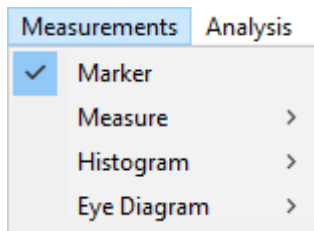

The **Measure** menu has three submenus that can be directly assigned to the side menu:

- **Parameter**
- **Definition**
- **Limit Test**

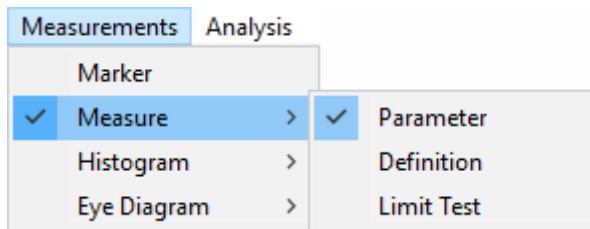

The **Histogram** menu has two submenus that can be directly assigned to the side menu:

- **Setup**
- **Window/Scale**

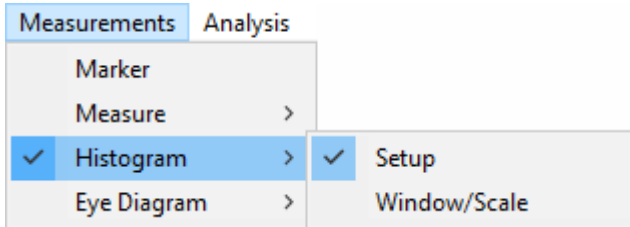

The **Eye Diagram** menu has two submenus that can be directly assigned to the side menu:

- **Parameter**
- **Definition**

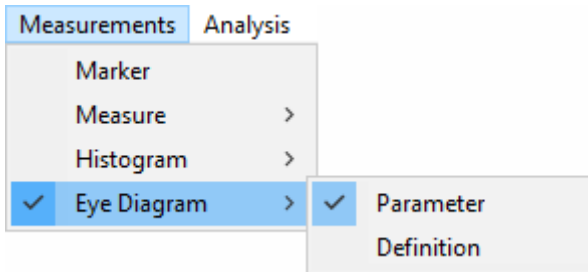

6.4.6 Analysis

The **Analysis** menu assigns the following items to the side menu:

- **Mathematics**
- **Mask Test**

The **Mathematics** menu has two submenus that can be directly assigned to the side menu:

- **Function**
- **Scaling**

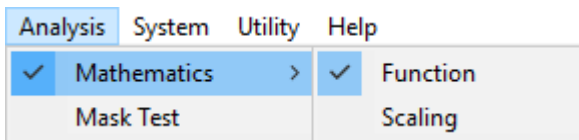

6.4.7 System

The **System** menu assigns the following items to the side menu:

- **Change Instrument**
- **Common LAN Setting**
- **Scanning LAN Instrument**

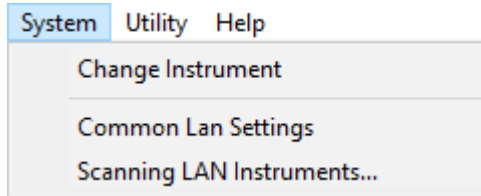

Change Instrument opens the Change Instrument dialog:

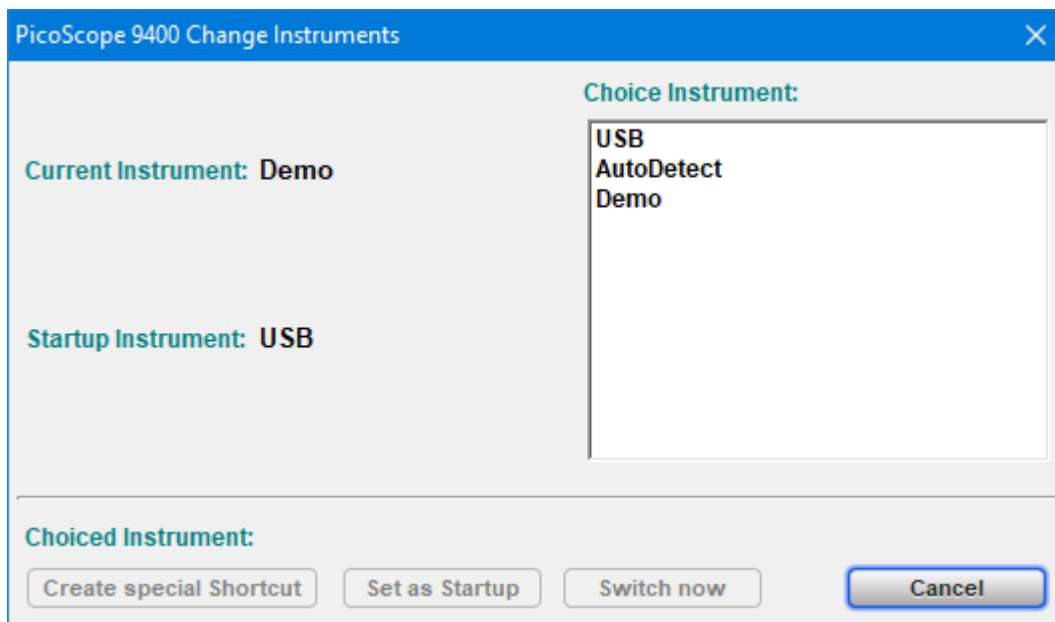

This dialog allows you select the instrument that should be assigned to the program. The following options can be used:

- The instrument connected by USB
- The instrument found with AutoDetect mode
- The Demo Mode instrument

Create special Shortcut creates a shortcut to the instrument on your desktop.

Common LAN Settings (not 9402 models) opens this dialog:

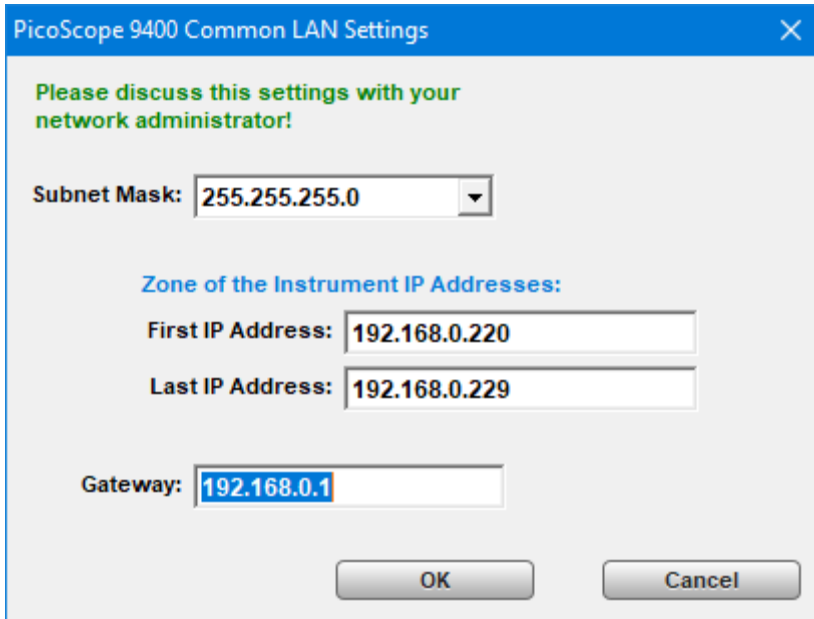

Select the settings appropriate to your LAN after consulting your network administrator.

LAN Instruments Scanning opens this dialog and starts a scan of IP addresses as defined in the **Common LAN Settings** dialog:

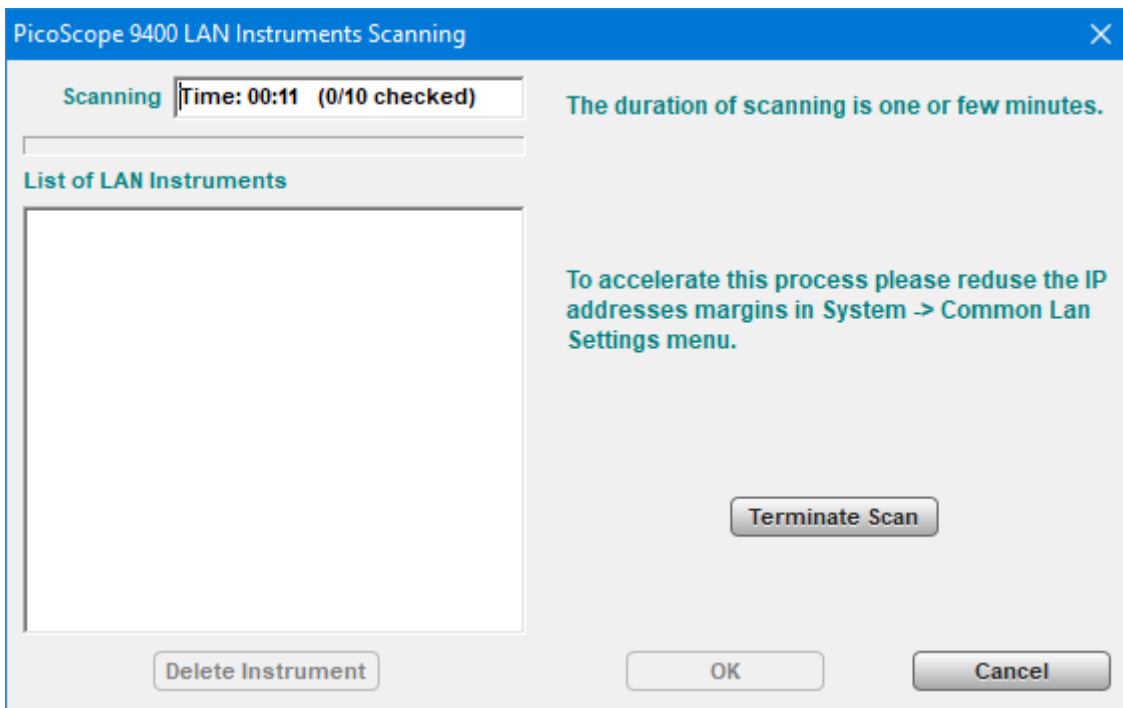

After the scan is finished, all found IP addresses will be displayed in the **List of LAN Instruments**. To confirm the scanning results, click **OK**.

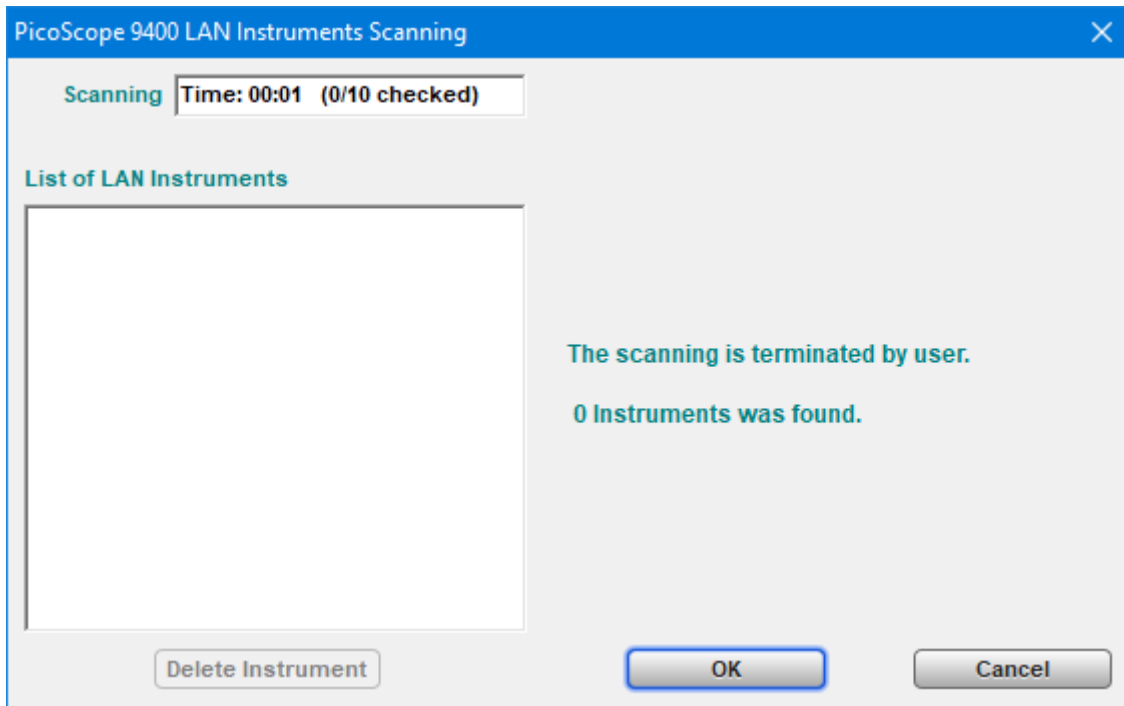

6.4.8 Utility

The **Utility** menu assigns the following items to the side menu:

- **Calibrate:** Channel 1/2, Channel 3/4 or Timebase calibration routine.
- **Demo:** In demonstration ('Demo') mode, when no scope is plugged in (see [Demo mode](#) for more information), five virtual signal generators labeled A to E are available to drive the input channels.
- **Adjustment:** This opens several menus used for the factory adjustment procedure. It is protected by a password.
- **Language:** This menu selects the language used in the *PicoScope 9400 User's Guide*. At the present time the only available language is English.

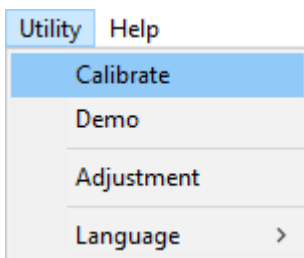

6.4.9 Help

The **Help** menu has two functions:

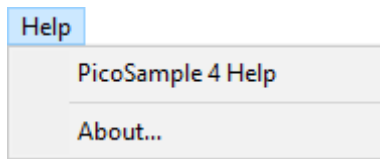

- **PicoSample 4 Help** activates the context-sensitive built-in information system on the instrument.
- **About...** shows information about the program and the instrument in use. It also allows you to change the instrument model in Demo mode, and to edit the TCP/IP properties of the instrument.

6.5 Measurement area

There are seven tabs that can appear in the **Measurement Area** at the bottom of the oscilloscope display depending on the selected current settings. Click on each of the tab headings to view measurement results.

The list includes the following tabs:

- Scales Tab
- Color Grade Tab
- Marker Tab
- Measure Tab
- Histogram Tab
- Eye Diagram Tab
- Mask Test Tab

The **Measurement Area** has four height settings: **Auto**, **Maximum**, **Middle** and **Minimum**.

Auto height provides active amount of rows, **Max** height provides 10 rows, **Mid** height provides 5 rows, and **Min** height provides 2 rows.

	Vertical Scale	Offset + Position	Horizontal Scale	Delay + Position
Channel 1	100 mV/div	0 V	10 ns/div	-50 ns
Channel 2	100 mV/div	0 V	10 ns/div	-50 ns
Channel 3	100 mV/div	0 V	10 ns/div	-50 ns
Channel 4	100 mV/div	0 V	10 ns/div	-50 ns
Function 1	100 mV/div	0 V	10 ns/div	-50 ns
Function 2	100 mV/div	0 V	10 ns/div	-50 ns

Measurement Area with auto height

	Vertical Scale	Offset + Position	Horizontal Scale	Delay + Position
Channel 1	100 mV/div	0 V	10 ns/div	-50 ns
Channel 2	100 mV/div	0 V	10 ns/div	-50 ns
Channel 3	100 mV/div	0 V	10 ns/div	-50 ns
Channel 4	100 mV/div	0 V	10 ns/div	-50 ns
Function 1	100 mV/div	0 V	10 ns/div	-50 ns
Function 2	100 mV/div	0 V	10 ns/div	-50 ns
Function 3	100 mV/div	0 V	10 ns/div	-50 ns
Function 4	100 mV/div	0 V	10 ns/div	-50 ns
Memory 1	100 mV/div	0 V	10 ns/div	-50 ns
Memory 2	100 mV/div	0 V	10 ns/div	-50 ns

Measurement Area with maximum height

	Vertical Scale	Offset + Position	Horizontal Scale	Delay + Position
Channel 1	100 mV/div	0 V	10 ns/div	-50 ns
Channel 2	100 mV/div	0 V	10 ns/div	-50 ns
Channel 3	100 mV/div	0 V	10 ns/div	-50 ns
Channel 4	100 mV/div	0 V	10 ns/div	-50 ns

Measurement Area with middle height



The screenshot shows the 'Scales' menu in PicoScope software. The menu is titled 'Scales' and contains the following settings for 'Channel 1':

Vertical Scale	Offset + Position	Horizontal Scale	Delay + Position
100 mV/div	0 V	10 ns/div	-50 ns

At the top right of the menu, there are four buttons: 'Auto', 'Max', 'Mid', and 'Min'. The 'Auto' button is currently selected.

Measurement Area with minimum height

6.6 Permanent controls

The **Permanent Controls** are located at the bottom of the display area. They are permanent because they are the most common functions that affect the waveform display. By using the **Permanent Controls** you have a quick reference to vertical, horizontal and trigger selections.

The **Permanent Controls** are:

- The **Channel 1-4** on/off check boxes, scale, position and offset settings.
- The **Timebase** scale, trigger position and delay settings.
- Trigger source, slope, mode, and level settings.

By clicking the right mouse button on a selected variable and choosing the **Calculator** command, you will obtain a pop-up numeric keypad allowing you to set a precise value.

Each channel has a check box allowing you to turn that channel on or off, and a set of controls allowing you to change the vertical scaling or offset. Only channels that are on are shown in matching colors.

The right-hand side of the permanent controls contains a selection of trigger controls. Trigger slope can be selected between **Positive**, **Negative**, and **Bislope**, while trigger mode can be selected between **Freerun** and **Trig'd**. You can set a particular trigger level.

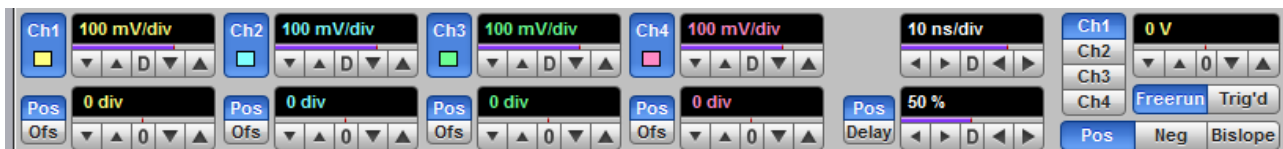

Permanent Controls

6.7 Pop-up keypad

The **Pop-up keypad** allows you to enter numeric values directly. You can use it with any numeric field in PicoSample 4: just right-click on the field and select **Calculator**. You can also type variables directly into numeric fields: first type the number, then finish by typing a single letter - p, n, u, m, X, K, A, G, T. (The meanings of these letters are explained below).

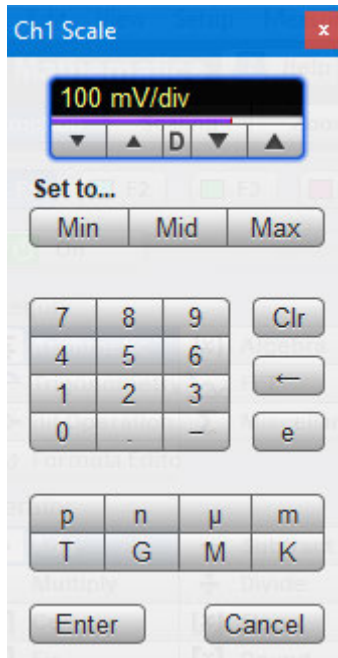

1. Choose the numeric field that you wish to edit.
2. Right-click on the field to bring up the context menu.
3. Click the **Calculator** command to bring up the **Pop-up keypad**.
4. Enter the new value numerically by clicking the number keys, then click one of the multiplier buttons to complete the value. (The **X** button means a multiplier of 1). Finally, click **OK** to update the numeric field:

Special Key Definitions

Min.	Enter the minimum value of selected variable.
Mid.	Enter the middle value of selected variable.
Max.	Enter the maximum value of selected variable.
Fine	Enter the value of selected variable with fine resolution.
Coarse	Enter the value of selected variable with coarse resolution.

Numeric value keypad

Minus (-)	Changes the sign of the mantissa (or the sign of the exponent if pressed after the exponent key).
------------------	---

Dimension keypad

p (pico)	Appends an exponent of 10 ⁻¹² to the number you have entered.
n (nano)	Appends an exponent of 10 ⁻⁹ to the number you have entered.
u (micro)	Appends an exponent of 10 ⁻⁶ to the number you have entered.
m (milli)	Appends an exponent of 10 ⁻³ to the number you have entered.
K (kilo)	Appends an exponent of 10 ³ to the number you have entered.
M (mega)	Appends an exponent of 10 ⁶ to the number you have entered. <i>Note: The keyboard shortcut for this key is A, not M.</i>
G (giga)	Appends an exponent of 10 ⁹ to the number you have entered.
T (tera)	Appends an exponent of 10 ¹² to the number you have entered.
Clr (clear)	Clears any numbers you have entered.
Backspace	Use the backspace key to erase the character to the left of the insertion point.
e (Exponent)	The number you enter after pressing this key is an power of 10.

6.8 Side menu

The side menus appear on the left and right sides of the waveform area.

Left-click a button on the toolbar to add the specified menu to the left menu area. Right-clicking sends the menu to the right menu area.

If the toolbar is not visible, display it using the **View > Toolbar** command on the **Main Menu**.

Remove a side menu by clicking the **Cancel** button .

6.9 Status area

The **Status Area** displays acquisition status, mode, and number of acquisitions, as well as the trigger status, date, time, and quick reference to record length and horizontal parameters.

6.10 System controls

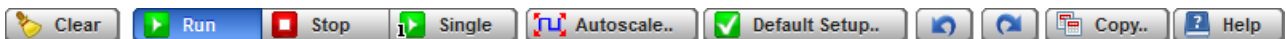

Using the **System Controls**, you control whether the oscilloscope is running or stopped. Other buttons allow you to reset the oscilloscope to its default setup, automatically configure the oscilloscope for the current signals (**Autoscale**), or erase the waveforms from the display.

The **System Controls** buttons are:

- Clear
- Run
- Stop
- Single
- Autoscale
- Default Setup
- Undo
- Redo
- Copy
- Help

6.10.1 Clear



Clicking the **Clear** button erases all channel waveform data from the graticule area. The following occur when the display graticule is cleared:

- All channel waveform data is erased from the graticule area.
- Functions, spectra and waveform memories are not erased from the display graticule when the clear display feature is executed.
- All associated measurements and measurement statistics are reset (averaging, color-grading, mask test data, limit test data, and histogram results), if enabled.

When the instrument is running

If the instrument is running and receiving triggers, new waveform data is displayed on the next acquisition, averaging is reset; and persistence and color-grading, histograms, the mask testing database and all measurements are recalculated.

When the instrument is stopped

If the instrument is stopped, the display remains cleared of waveform data until the trigger circuit is rearmed and the instrument is triggered. Then the new data is displayed and measurements are recalculated.

6.10.2 Run, Stop and Single



The **Run** button causes the instrument to resume acquiring data. If the instrument is stopped, it starts acquiring data on the next trigger event. If the instrument is already in the run mode, it continues to acquire data on successive trigger events.

If pressing the **Run** button does not cause waveform data to display on the screen, try the following:

- Make sure a signal is connected to one of the channel and the display for that channel is turned on.
- Make sure the offset does not have the trace clipped off the display.
- Check the trigger setup conditions to make sure the trigger conditions are valid for the signal.
- Set the trigger mode to **Freerun**. **Freerun** forces the instrument to trigger, which may allow you to see enough of the signal so that you can set up the front panel properly.
- Click the **Autoscale** button.

The **Stop** button causes the oscilloscope to stop acquiring data. You can stop acquisition if you want to freeze the displayed waveform(s) for closer analysis or measurement.

The **Single** button causes the oscilloscope to perform a single waveform acquisition. Each subsequent press of the **Single** button rearms the trigger circuit. A complete acquisition cycle is performed, and any measurements are recalculated.

If all the channels are turned off or if a trigger event is not found, the instrument will not acquire any data.

6.10.3 Autoscale



Adjusting an oscilloscope to display a stable trace of usable size and amplitude can be a time-consuming process. The **Autoscale** feature of the PicoScope 9400 Series can quickly give you a stable, meaningful trace display.

The **Autoscale** button causes the instrument to quickly analyze any waveforms connected to the trigger and channel inputs. Then, it sets up the vertical, horizontal, and trigger controls to best display that signal.

When you click the **Autoscale** button, you tell the PicoScope 9400 Series oscilloscope to examine the signal and adjust the following controls for optimum display:

- Vertical scale and offset
- Timebase scale and delay
- Trigger level, if appropriate to that trigger source

The PicoScope 9400 scope must have an available trigger source and input. For example, if you are using Ch1 as a trigger input, the trigger signal must be connected to this trigger input.

The **Autoscale** function can find repetitive signals with:

- Frequency greater than 50 Hz
- Duty cycle greater than 1%
- Vertical amplitude greater than 50 mV p-p
- Trigger amplitude as specified

Autoscale is operative only for relatively stable input signals. **Autoscale** looks for signals on all channels, even if they are turned off. It also searches for a trigger signal on the trigger inputs.

If the **Autoscale** button is pressed unintentionally, use the **Undo** button to return the instrument to the settings that existed before.

6.10.4 Default setup

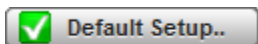

The **Default Setup** button returns the instrument to its default settings. This places the oscilloscope in a known operating condition. You may find it helpful to use this known operating condition when someone else has used the oscilloscope before you. If you accidentally press the **Default Setup** button, use the **Undo** button to return the oscilloscope to the operating condition it was in before **Default Setup** was pressed.

Right-click on the button to get four options:

- **Default Setup** Returns the instrument to its default settings.
- **Factory Setup** Returns the instrument to default setting of the manufacturer.
- **Power Off Setup** Returns the instrument to the last setting before switching off the power supply.
- **Save As Default** Stores the present settings as the default setup.

6.10.5 Undo, Redo

Undo  and **Redo** 

You may find situations where you have unintentionally selected an unnecessary control. When this happens, you can use the **Undo**  button to return the oscilloscope to the previous settings. The depth of undo can be up to 100 steps.

If you later decide you didn't want to undo an action, right-click the button and select **Redo** .

6.10.6 Copy

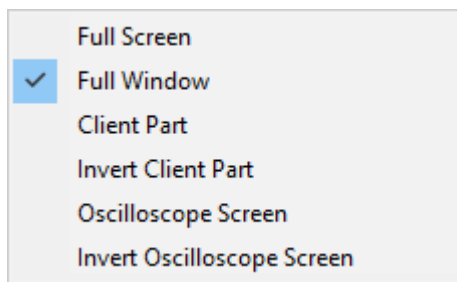
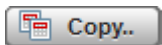

Clicking the **Copy** button copies different programming windows to the **Windows Clipboard**. From there, you can paste copied information into such **Windows** programs as **Word, Corel Draw, Paintbrush** and **Photoshop**.

Use the **Copy** function when preparing documentation based on usage of the PicoScope 9400 Series oscilloscopes.

Right-click the button to get six options:

- **Full Screen**
- **Full Window**
- **Client Part**
- **Invert Client Part**
- **Oscilloscope Screen**
- **Invert Oscilloscope Screen**

6.10.7 Help



The **Help** button has two functions:

- Click to activate the context-sensitive built-in information system on the instrument. This changes the pointer into a context-sensitive help icon. You can then click any control to open the manual at the relevant page.
- Right-click to open the **PicoScope 9400 Help** manual or the **About...** dialog.

These options can also be accessed by clicking Help in the main menu.

About...

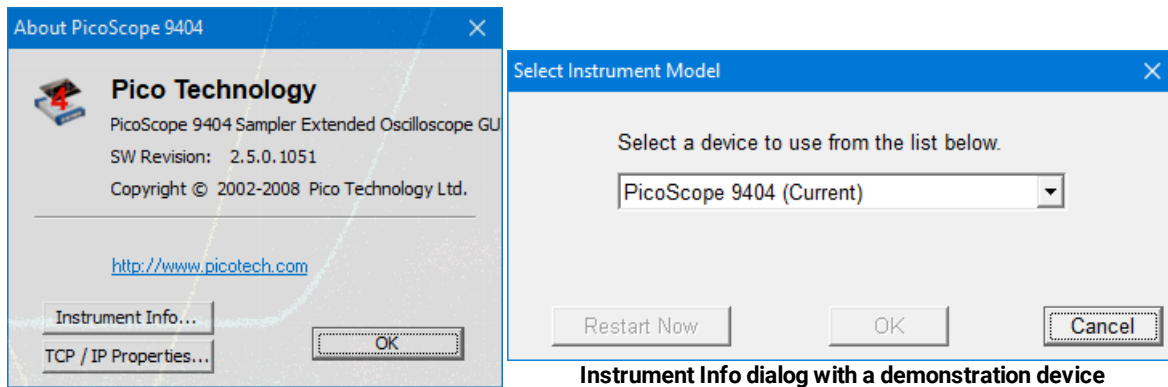

Instrument Info dialog with a demonstration device

About... and Instrument Info dialogs from the Help menu

Click **About...** to view some basic information about the oscilloscope and software that you are currently using. Click the **Instrument Info...** button to view information about the connected device.

If you are using PicoSample 4 in **Demo mode**, without an oscilloscope connected (see [Demo mode](#) for more information), you can use the **Instrument Info** dialog to change the model of the demonstration device. The dialog shows information about the current demonstration device; click **Change Model** to select a different model. To update the software you will then need to restart PicoSample 4.

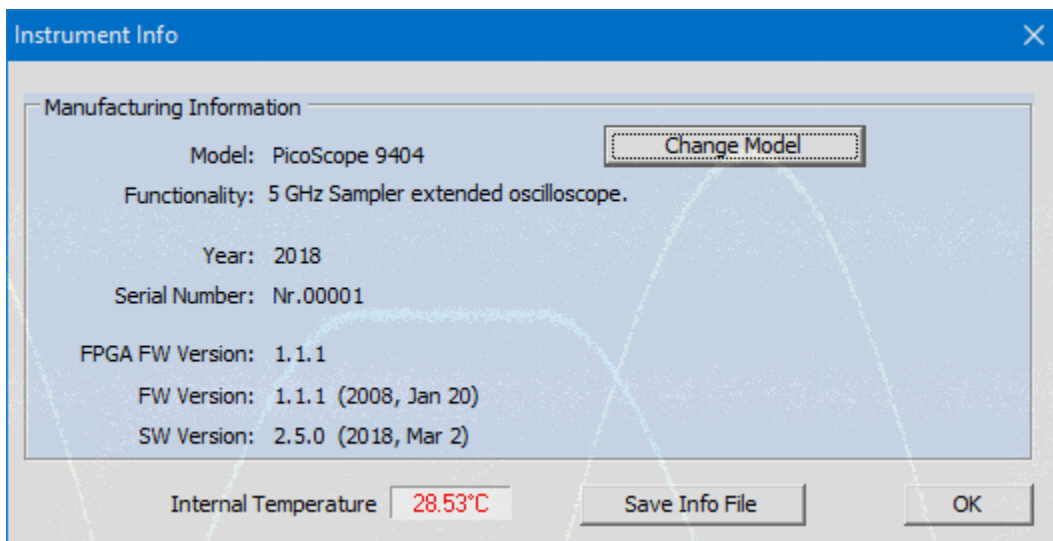

Instrument Info dialog with a demonstration device

6.11 Startup

If you start PicoSample 4 without a device connected, the **Initialisation...** dialog will automatically appear with three buttons, as shown below.

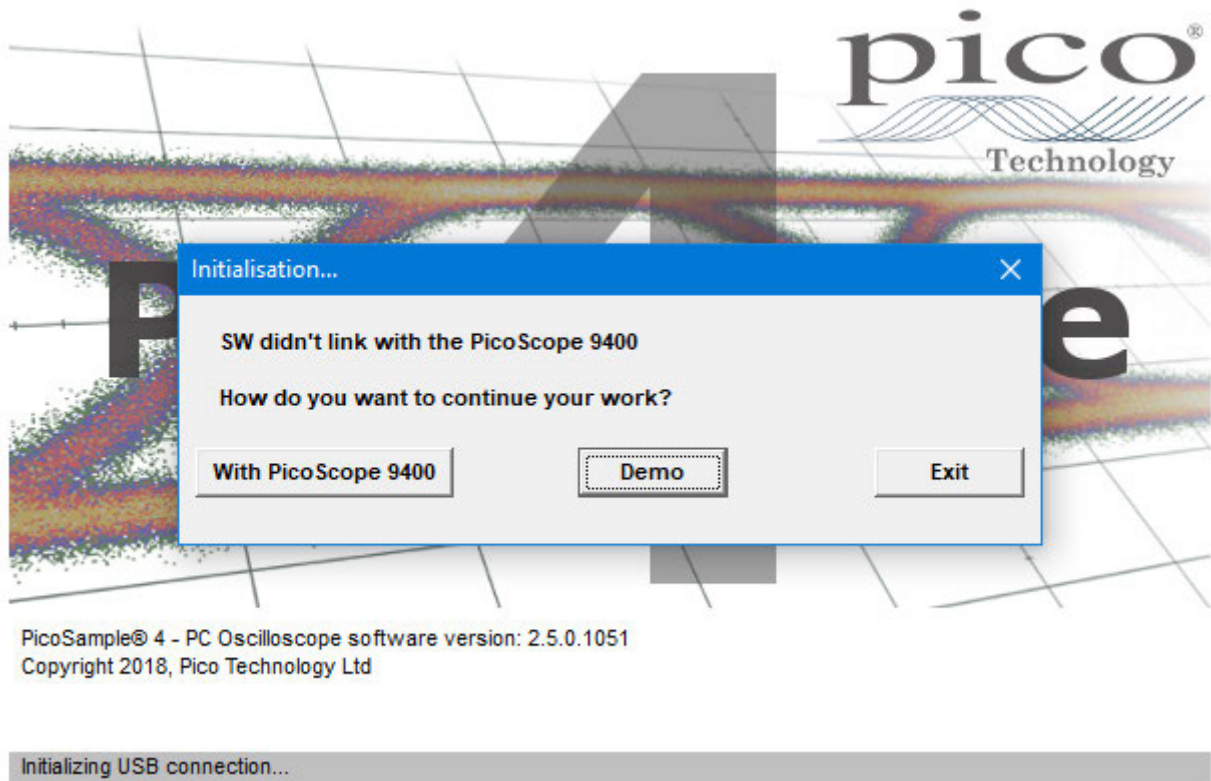

- **With PicoScope 9400:** Connect a PicoScope 9400 Series oscilloscope and then click this button to continue opening the software.
- **Demo:** Start the software with a demonstration waveform. See [Demo Mode](#) for more information.
- **Exit:** Close the software.

6.12 Toolbar

The **Toolbar** includes up to 12 buttons located at the bottom of the instrument display.

The **Toolbar** is used to:

- Set up the oscilloscope operating modes (**Channels**, **Acquire**, **Trigger**, and **Display** menus)
- Set up and execute waveform measurements (**Marker**, **Measure**, **Histogram**, and **Eye Diagram** menus)
- Control file management tasks (**Save/Recall** menu)
- Perform waveform analysis (**Math** and **Mask Test** menus)
- Set up and execute instrument calibration, and to use a demo mode (**Utility** menu)



Clicking on any button of the **Toolbar** with the right mouse recalls the **Right Side Menu**. Clicking on any button of the **Toolbar** with the left mouse recalls the **Left Side Menu**.

7 Menu

7.1 Channels Menu

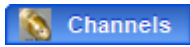

CAUTION! The input circuits can be damaged by electrostatic discharge. Therefore, avoid applying static discharges to the front panel input connectors. Before connecting any coaxial cable to the connectors, momentarily short the center and outer conductors of the cable together. Avoid touching the front panel input connectors without first touching the case of the instrument. Personnel should be properly grounded, and should touch the case of the instrument before touching any connector. Be sure that the instrument and PC are properly earth-grounded to prevent build-up of static charge. Repair of damage due to misuse is not covered under the warranty!

The **Channels** menu allows you to set all controls for vertical setups of all live waveforms.

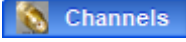
To display the **Channels** menu, click the  button from the [Permanent Controls Area](#). The controls for each channel are independent. When you select the **Channels** menu, either the **Scale**, **Offset**, **Position**, **Deskew**, or **Attenuation** control is highlighted in the same color as the selected channel, indicating that the function is active.

The **Channels** menu has two submenus: [Setup](#) and [Zoom](#).

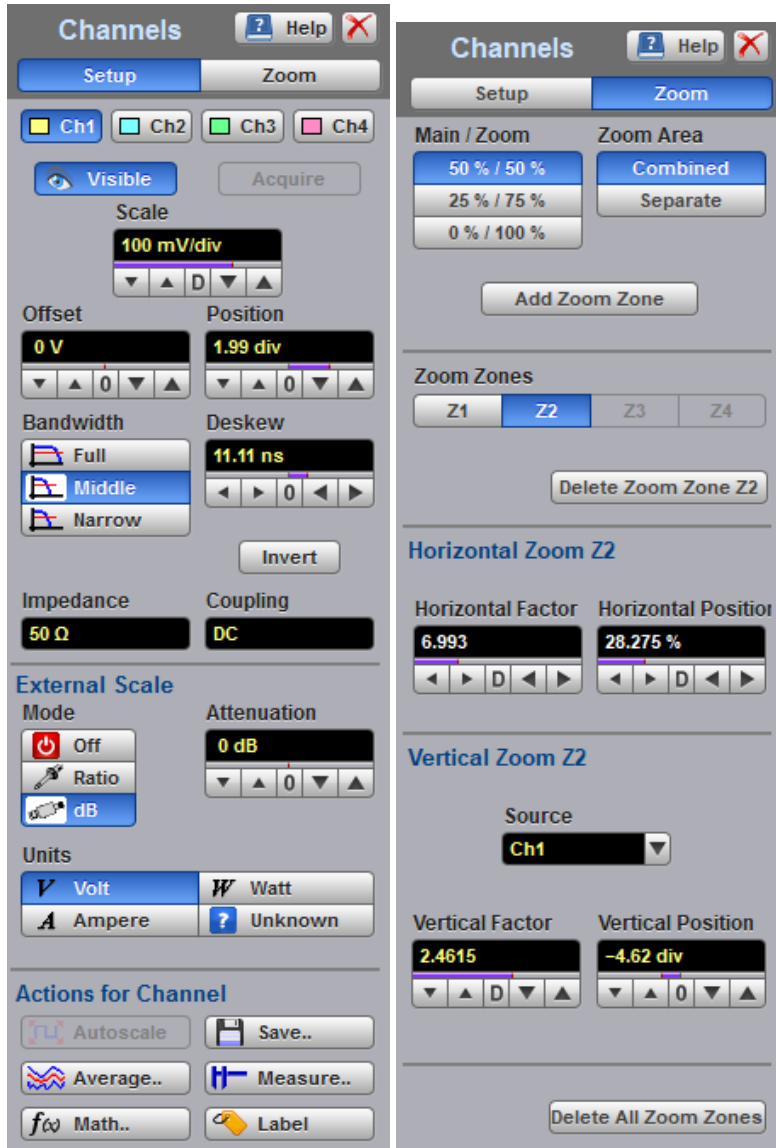

The Channels Menu

7.1.1 Channel Setup

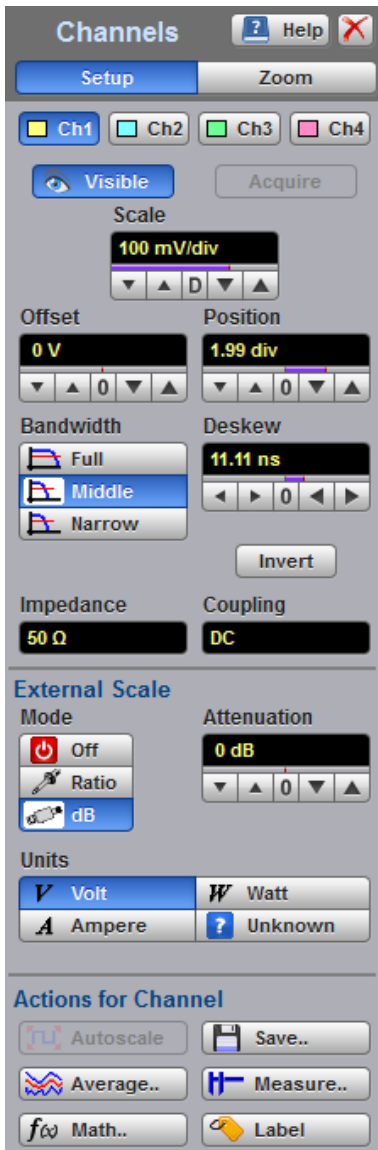

The Channels Setup Menu

The **Channel Setup** menu allows you to select and display the waveform of each channel, to control scale, offset, position, bandwidth and deskew, to invert the waveform and to control external scale.

7.1.1.1 Channel Select



The PicoScope 9400 Series oscilloscopes have two or four channels numbered Ch1 through Ch2 to Ch4. The instrument can simultaneously acquire, display and perform measurements on all channels.

Many of the controls of the PicoScope 9400 Series, especially the channel controls, operate on the selected channel. The instrument applies all actions that only affect one channel at a time, such as applying changes to the vertical control settings, to the selected channel. Since it is possible that all traces will be on the screen at the same time, each trace is displayed in a separate color.

Clicking the **Ch1**, **Ch2**, **Ch3**, or **Ch4** buttons:

- Toggles it between channels 1 and 4.
- Assigns the function keys to the selected channel.

7.1.1.2 Channel Display



There are two ways to add selected channels to the display and remove them again:

- Use the **Visible** button.
- Use the **Ch1–Ch4** check boxes in the [Permanent Controls Area](#).

Clicking the **Visible** button:

- Turns the display for the selection on or off.
- Changes the label from on to off or vice versa.

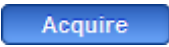
Turning the display off does not turn off acquisition of the selected channels. To turn off acquisition of the selected channel, use the [Acquire](#) button .

When the **Visible** button changes from on to off, while the **Acquire** button is on, the [Status Area](#) for the

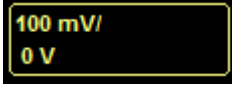
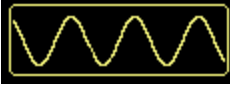
selected channel also changes its status from  to . This status shows that the channel is removed from display but its acquisition is still going on.

Visible turns on or off the display of the waveform for the chosen channel. When the channel display is on, a waveform is displayed for that channel, unless the offset is adjusted so the waveform is clipped off of the display. Turning a channel's display off turns off the markers, measurement define parameters, histogram window and eye window. However, turning a channel's display off doesn't turn off marker measurements, automatic measurements, histogram measurements, eye-diagram measurements or mask test. Functions and FFTs will also be available for that channel. Turning a channel off increases the display update rate for the channels that remain on.

7.1.1.3 Channel Acquire

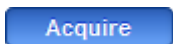

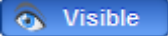
Turning the display off with the **Visible** button  does not turn off acquisition of the selected channels. To turn off acquisition of the selected channel, use the **Acquire** button.

When the **Acquire** button changes from on to off, while the **Visible** button is off, the [Status Area](#) for the

selected channel also changes its status from  to .

This status shows that the channel is removed from the display and its acquisition is stopped. Stopping acquisition turns off marker measurements, automatic measurements, histogram measurements, eye-diagram measurements and mask tests for the selected channel. Functions and FFTs based on this channel will be also removed.

7.1.1.4 Channel Scale



You can use the vertical **Scale** controls to change the volts-per-division setting for any channel to increase or decrease the amplitude of your waveform. It determines the portion of the input signal presented to the acquisition system. Adjust the **Scale** to control the portion of the vertical window displayed on screen. The vertical window is always centered around the offset value that is set and not around the ground reference.

As the numeric value of the scale is increased, the displayed waveform decreases in size, and as the numeric value of the scale is decreased, the waveform increases in size.



The **Scale** control provides graphical scaling only; it has no effect on the vertical acquisition window.



Only waveform traces from input channels can be vertically adjusted with the **Scale** control. It does not affect waveforms saved in memories, or waveform functions.

You can set the vertical sensitivity of the selected channel in one of four ways:

- Use the **Scale** spin box.
- Use the **Ch1–Ch4** spin boxes in the [Permanent Controls area](#).
- Use the [Drag and Zoom](#).
- Use the [Pop-up Keypad](#) to enter specific settings.

You can change the vertical scaling from 10 mV/div to 250 mV/div. If fine mode is off, the vertical scaling is in a 10-12.5-15-20-25-30-40-50-60-70-80-90-100-125-150-200-250 mV/div sequence. When fine mode is on, you can change the vertical scaling with a 1% fine increments or better. With manual or calculator data entry the increment is 0.1 mV/div.

You can also use [Zoom](#) menu to adjust the vertical scale.

The **Scale** changes automatically if the attenuation factor is changed (see [Attenuation](#)). The units the scale is displayed in depend on the unit of measure selected with the [Units](#) menu. The choices for units are volts, watts, amperes, or unknown. The **Scale** changes automatically if the display graticule mode (single, dual or quad) or the attenuation factor is changed.

7.1.1.5 Channel Offset

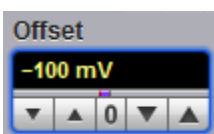

You can use the vertical **Offset** controls to move your waveform either up or down on the display. The **Offset** variable changes the vertical position of a particular channel's waveform on the display screen without modifying the waveform itself. It determines the portion of the input signal presented to the acquisition system.

The advantage of digital offset is that it is calibrated. The offset voltage is the voltage at the center of the graticule area, and the range of offset is ± 1 V. As you vary the offset, the middle voltage level moves relative to zero. This moves the vertical acquisition window up and down on the waveform. With input signals that are smaller than the window, the waveform appears to move in the window. Applying a negative offset moves the vertical range down relative to the DC level of the input signal, moving the waveform up on the display. Likewise, applying a positive offset moves the vertical range up, moving the waveform down on the display.

Set the vertical offset to display the features of interest on your waveform and avoid clipping.

Each channel has its own **Ground Reference Indicator**  located to the left of the graticule area. The **Ground Reference Indicator** shows you where zero volts is for each electrical channel.



Waveform data outside the vertical acquisition window is clipped: that is, the data is limited to the minimum and/or maximum boundaries of the vertical acquisition window. This limiting can cause inaccuracies in amplitude-related measurements.



The **Offset** control affects the vertical acquisition window for the selected input channel. It does not affect waveforms saved in memories, or waveform functions.

You can move the trace of the selected channel up or down in one of five ways:

- Use the **Offset** spin box.
- Use the **Ch1 - Ch4** offset spin boxes from the [Permanent Controls Area](#).
- Use the [Drag and Zoom](#).
- Use the [Pop-up Keypad](#) for some specific settings.
- Drag the channel **Ground Reference Indicator**.

If fine mode is off, the offset can be changed in 10 mV steps. When fine mode is on, you can change the offset in 2 mV steps. With manual or calculator data entry the increment is 0.01 mV for offset between -99.9 and 99.9 mV, and 0.1 mV for offset between -999.9 and 999.9 mV.

The **Offset** changes automatically if the attenuation factor is changed. The units the offset voltage is displayed in depend on the unit of measure selected with the Scale menu. The choices for units are volts, watts, amperes, or unknown. The **Offset** changes automatically if the display graticule mode (single, dual or quad) or the attenuation factor is changed. During an **Autoscale**, an offset is applied to vertically center the signal.

7.1.1.6 Channel Position



Use the **Position** variable to set the vertical position of the selected channel on the display without changing its offset value. The visual effect is the same as for the **Offset** but the waveform is adjusted at a later time in the signal flow.

The **Position** variable increments and decrements the waveform position by 0.25 division (one minor graticule division), or 0.01 division (0.04 minor graticule division) when fine mode is on. With manual or calculator data entry the increment is three significant digits, for example, 1.99 div.

Increasing the position value of a waveform causes the waveform to move up, and decreasing the position causes the waveform to move down.

7.1.1.7 Channel Bandwidth

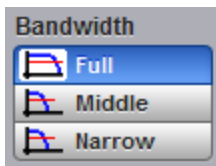

Bandwidth is the range of frequencies that an oscilloscope can acquire and display accurately (that is, with less than ± 3 dB attenuation). You can use the **Bandwidth** function to select either full, middle, or narrow bandwidth.

The wider bandwidth option allows the instrument to respond to fast changes in a waveform. The increased bandwidth thus yields the highest measurement fidelity.

More narrow bandwidth offers the best sensitivity by reducing the noise on the input waveform. A lower bandwidth is especially useful for low-level signals that cannot be averaged, such as an eye diagram. If you do not need wide bandwidth, use the middle, or even narrow bandwidth to keep the signal-to-noise ratio at the best possible level.

The **Bandwidth** does not affect the trigger signal.

- **Full.** This button selects 16 GHz bandwidth with 2.2 mV typical RMS noise for the 16 GHz models, or 5 GHz bandwidth with 1.6 mV typical RMS noise for the 5 GHz models.
- **Middle.** This button selects 450 MHz bandwidth with 650 μ V typical RMS noise. Not applicable to 9402 models.
- **Narrow.** This button selects 100 MHz bandwidth with 450 μ V typical RMS noise.

7.1.1.8 Channel Deskew

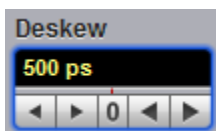

The **Deskew** variable adjusts the skew to change the horizontal position of one active channel with respect to another on the instrument display. The **Deskew** function has ± 50 ns range. Coarse increment is 100 ps, fine increment is 10 ps. With manual or calculator data entry the increment is four significant digits or 1 ps.

Use the **Deskew** to compensate the time offset between two or more channels, and also differences in cable or probe lengths. It also allows you to place the triggered edge at the centre of the display when you are using a power divider connected between different channels. Another use for deskew is when you are comparing the shapes of two waveforms rather than the actual timing difference between them: you can use the **Deskew** to overlay one waveform on top of the other.

The **Deskew** function allows you to set the horizontal position of a waveform in one of two ways:

- Use the **Deskew** spin box.
- Use the [Pop-up Keypad](#) to enter specific settings.

7.1.1.9 Channel Invert

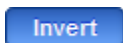

Click the **Invert** to invert selected channel waveform.

7.1.1.10 Channel Input Impedance

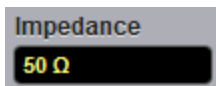

The input channels of the PicoScope 9400 Series oscilloscopes have 50 Ω input impedance with DC input coupling. This is useful for connecting to probes or circuits that require a 50 Ω termination. For example, you might choose an active probe to measure a very fast ECL, SiGe or GaAs circuit. Such a probe usually has an amplifier near the tip of the probe, which drives the signal through a 50 Ω cable. To minimize any waveform reflections, the scope input impedance must match the cable impedance as closely as possible so you would choose the 50 Ω setting for that channel's input impedance.



CAUTION

To avoid damage to the input of the scope, make sure you do not exceed the channel's maximum rated input voltage of **±1.4 V (DC + peak AC)**.

Using resistive divider probes you can increase the input impedance up to 5 kΩ, and using an active probe you can increase input impedance up to 10 MΩ.

7.1.1.11 Channel Input Coupling

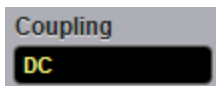

PicoScope 9400 Series oscilloscopes provide only straight-DC coupling to input circuits, with no protection. We specify a maximum vertical non-destructive range that limits signals to a small level of ±1.4 V (DC + peak AC) or 13 dBm. See [Vertical Specification and Characteristics](#) for exact limits.



CAUTION!

Do not exceed the limit, even momentarily, as the input channel may be damaged.

**CAUTION!**

The PicoScope 9400 Series oscilloscopes have a specified maximum operating input voltage (dynamic range) that, if exceeded, could cause acquisition and measurement errors due to non-linearity. This limit is equal to ± 0.8 V range. Do not exceed this limit.

For removing the DC component of a particular channel's waveform to view AC waveforms with large DC offsets, use external wide-bandwidth HF blocking capacitors. Use external attenuators if necessary to prevent exceeding the limits just described.

7.1.1.12 Channel External Scale

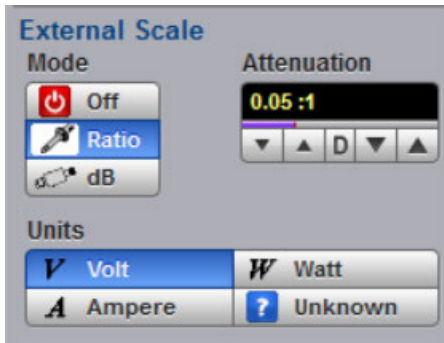

The **External Scale** functions allow you to set up a channel of the instrument to use external voltage attenuators or probes, current probes, or optical-to-electrical converters. Scaling is automatically adjusted to calculate and display information at the input side of an external device. For example, you may need to reduce the voltage level of a pulse generator that exceeds a channel's maximum input level. If you add a 20 dB attenuator, the voltage is reduced by a factor of 10:1. Although the voltage levels into the channel are within acceptable limits, your source measurements will be 1/10th of the actual source level. External scaling allows you to compensate for the 20 dB attenuation so your measurements reflect the source level prior to attenuation.

The measurement result reflects the actual value at the external device input. Once the number has been entered (1 is the default), the instrument then uses the total attenuation factor in scaling measurement results. Total attenuation is the product of the external attenuation multiplied by the hardware attenuation of the probe (or another external unit) or sampler.



When you enter attenuation, amplification, or conversion information with the External Scale menus, the channel settings change in the following ways:

- The unit values and amplitudes of the markers and vertical measurements reflect the signal at the input of a transducer, probe, attenuator, or amplifier. For example, you can connect an external device such as a photodiode to an electrical channel input and change the scale unit value to read watts, the unit value of the signal at the diode input.
- The maximum and minimum vertical scale settings change by a factor specified by the attenuation value entered.
- Offset minimum and maximum values change by a factor specified by the attenuation value entered.

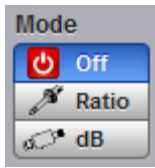
7.1.1.13 External Scale Mode



You can enter attenuation or gain characteristics of an external device when configuring a channel for external scaling. The **Mode** function lets you select how you want the attenuation factor represented.

Click the **Ratio**  or the **Decibel**  radio buttons to choose either ratio or decibel.

The formula for calculating decibels is: $20 \log(V_{out}/V_{in})$ or $10 \log(P_{out}/P_{in})$

Decibels versus voltage ratio

dB	Voltage Ratio
3 dB	1.41
6 dB	2.00
10 dB	3.16
20 dB	10
40 dB	100
60 dB	1000
120 dB	1 000 000
-80 dB	0.000 1

Changing the channel attenuation factor does not attenuate the input signal; it only changes the database for generating prompts on the display and calculating the results of the automated waveform measurements. If the input signal must be attenuated, use external attenuators.



External gain is implied when you enter negative decibel values or ratios of less than 1:1 in the **Attenuation** variable. The default attenuation value is 1:1.

7.1.1.14 External Scale Attenuation



The **Attenuation** variable lets you select an attenuation that matches the device connected to the instrument. When the attenuation is set correctly, the instrument maintains the current scale factors if possible. All marker values and voltage, amperage or wattage measurements will reflect the actual signal at the input to the external device.

The channel attenuation factor is used to establish a database for:

- Generating the vertical scale and offset prompts on the display.
- Calculating the automated waveform measurements.
- Y-marker levels.
- Calculating functions.

The attenuation factor can be adjusted from 0.000 1:1 to 1 000 000:1 or from -80 dB to 120 dB.

The **Attenuation** function allows you to set attenuation of the selected channel in one of two ways:

- By using the Attenuation spin box.
- By using the **Pop-up Keypad** to enter specific settings.

7.1.1.15 External Scale Units

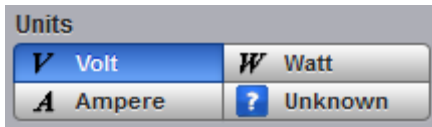

The **External Scale Units** function lets you select a unit of measure that is appended to the channel scale, offset and vertical measurement values. The units are **Volt**, **Watt**, **Ampere**, or **Unknown**.

Use **Volt** for voltage probes or attenuators, **Ampere** for current probes, **Watt** for optical-to-electrical converters, and **Unknown** when there is no unit of measure or when the unit of measure is not one of the available choices.

7.1.2 Zoom

The **Zoom** menu allows you to select one from four zoom areas, to zoom and position any of the selected zoom areas horizontally or vertically.

For more details see [Zoom Menu](#).

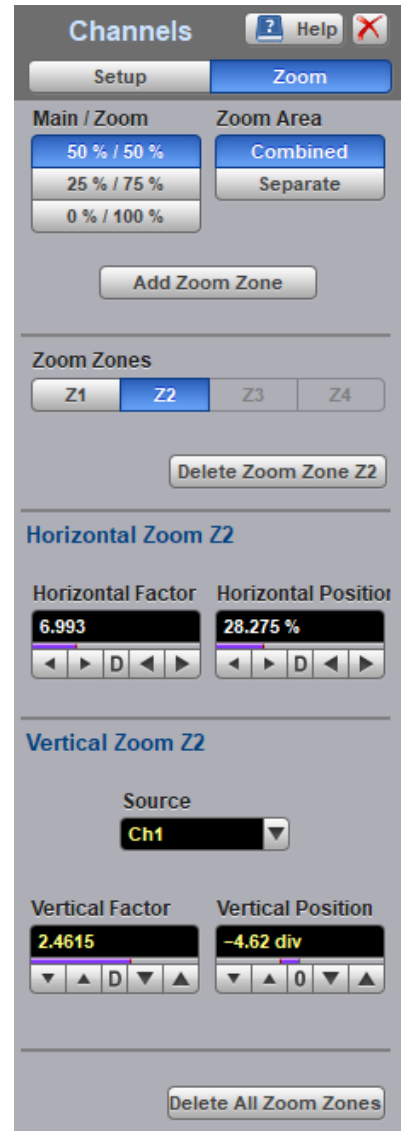

The Zoom Menu

7.2 Acquire Menu

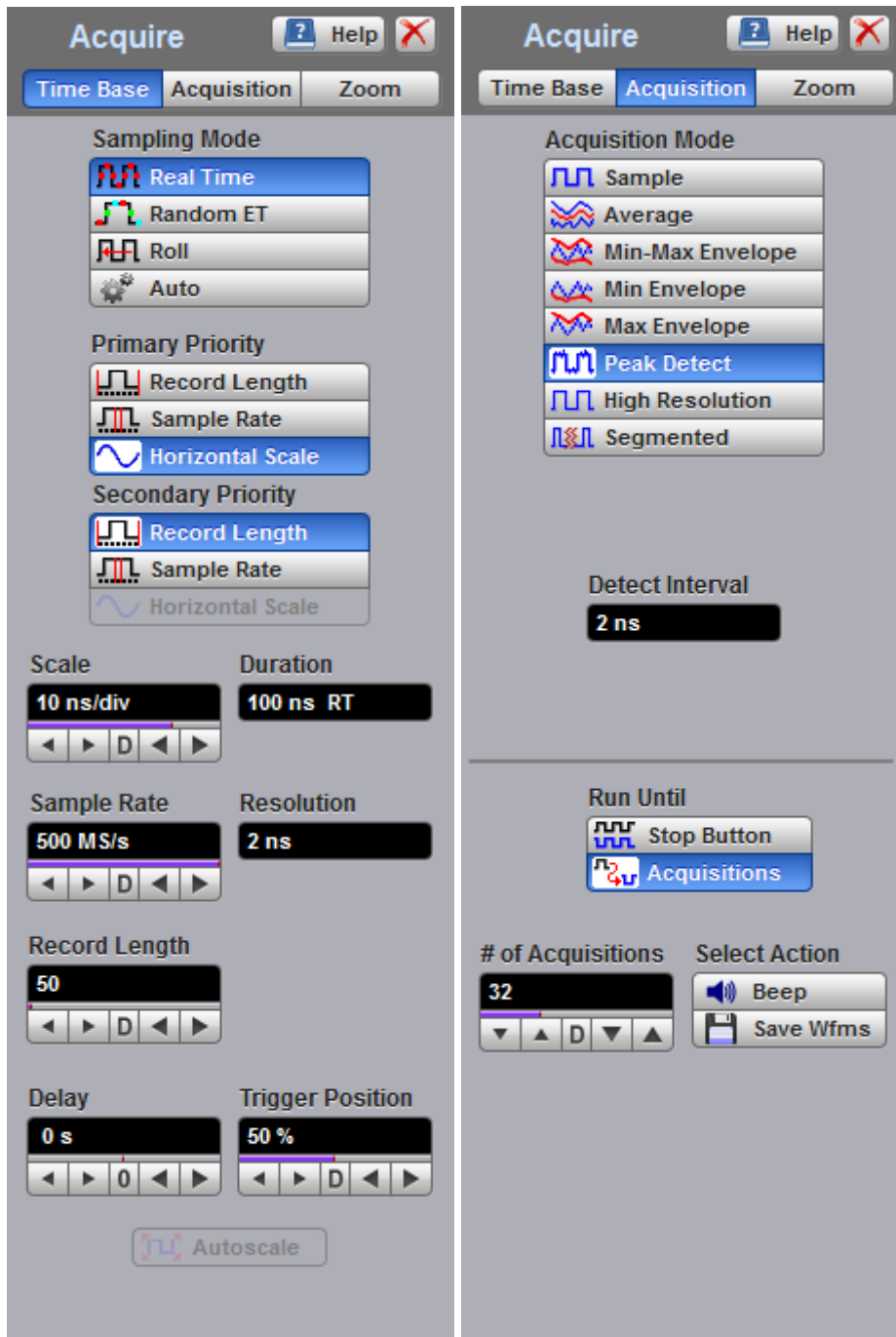

The Acquire Menu

7.2.1 Time Base

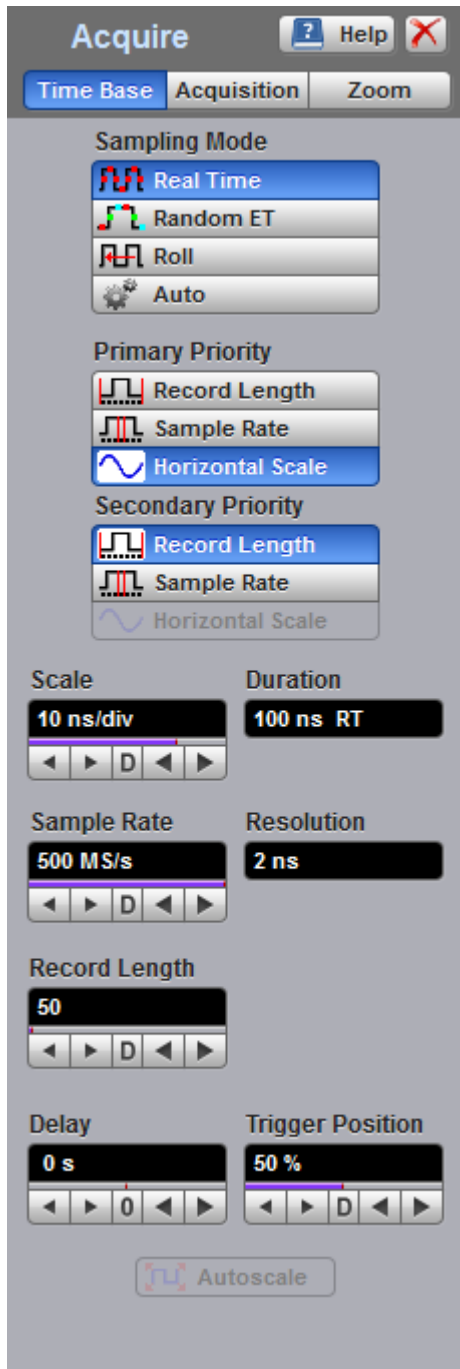

The Time Base Menu

7.2.1.1 Sampling Mode

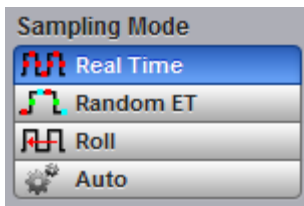

The PicoScope 9400 Series oscilloscopes offer three sampling modes: **Real Time**, **Random Equivalent Time** and **Roll**. **Auto** enables the oscilloscope to choose the most appropriate sampling mode.

Real Time Sampling Mode

Real Time Sampling captures all of the sample points used to reconstruct a waveform during a single trigger event. It also requires a sample rate that is at least 2.5 times the highest frequency in the waveform or else you will get a distorted or aliased view of your waveform. The following figure shows how a waveform is sampled in real time.

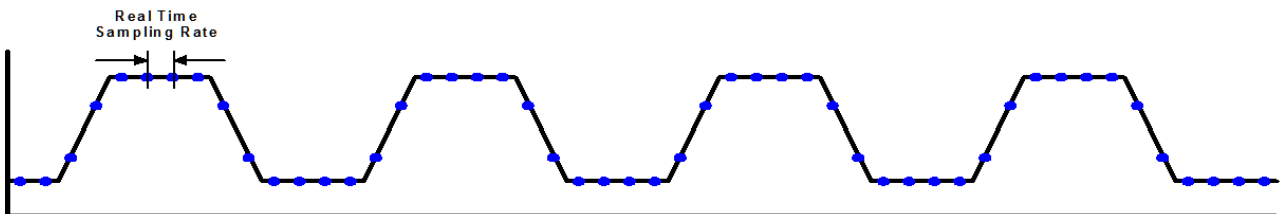

Real Time Sampling

Once the trigger is armed, the oscilloscope starts acquiring data until the trigger event you have specified occurs. Because the PicoScope 9400 Series scope acquires data while the trigger is armed, waveform samples before or after the trigger event are in the oscilloscope's acquisition memory. You can configure the PicoScope 9400 Series oscilloscopes to acquire only pre-trigger waveform samples, only post-trigger waveform samples, or both pre-trigger and post-trigger waveform samples. The maximum real time sampling rate of the PicoScope 9400 Series is 500 MHz.

Random Equivalent Time Sampling

The instrument uses equivalent time sampling to extend its sample rate beyond its real-time maximum sampling rate. In this sampling mode the PicoScope 9400 Series scope acquires sample points over several trigger events, requiring the input waveform to be repetitive. On each trigger event, the scope acquires more points and combines them with the previously acquired points. This creates a record of the waveform that has an effective sampling rate much higher than real time sampling rate.

The following figure shows how a waveform is sampled in **Random Equivalent Time** mode. The samples are labeled with different colors to indicate the trigger event when they were acquired. Thus, samples labeled with green were acquired during the first trigger event. Those samples labeled with brown were acquired during the second trigger event, and so on.

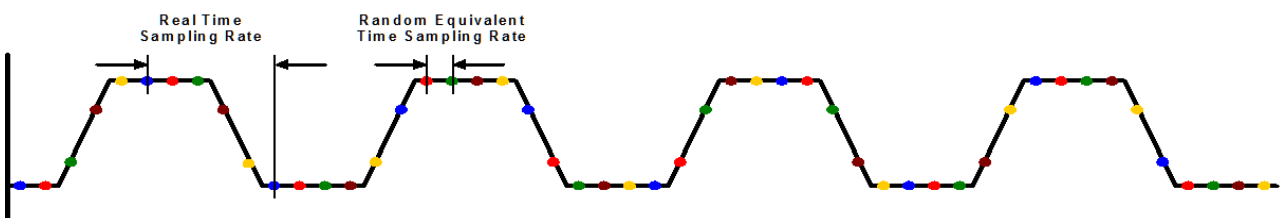

Random Equivalent Time Sampling

The real-time sampling rate used in the PicoScope 9400 Series is 500 MHz, while the best hardware time interval resolution in **Random Equivalent Time Sampling** mode is 0.4 ps.

Roll Mode

When **Roll** is enabled, acquisition data will be displayed in a rolling fashion starting from the right side of the display and continuing to the left side of the display (while the acquisition is running). Roll mode is a triggerless acquisition mode so there is no trigger reference and all trigger features are disabled. New data will continue rolling across the screen while the acquisition is running. If the acquisition is stopped before a full screen of data is acquired, the portion of data that has been acquired will be displayed with a time-zero reference at the right screen edge and the remaining portion of the display will be left blank. If a control change is made while the acquisition is running, the acquisition is halted and restarted and the old data is cleared from the display and measurement statistics.

Use **Roll Sampling Mode** when making manual adjustments to your low-frequency waveforms, when you want to find disturbances in your low-frequency waveforms, or to monitor the power-up cycle of a power supply voltage.

7.2.1.2 Scale and Duration



The **Scale** function is similar to the time/div knob of the timebase on a traditional oscilloscope. *Division* in this instance equals 1/10 of the horizontal axis. Adjusting the horizontal (timebase) scale control expands and compresses the displayed waveform horizontally.

The **Scale** controls horizontal scaling of the waveform. You can set the timebase scale from 20 ps/div to 1000 s/div in one of three ways:

- By using the **Scale** spin box
- By using the corresponding spin box in the [Permanent Controls Area](#)
- By using the [Pop-up Keypad](#) to quickly enter numeric data for the timebase scale using the mouse

In **Real Time Sampling Mode** you can set the timebase scale from 10 ns/div to 1000 s/div in a 1-2-5-10 coarse sequence.

In **Random Equivalent Time Sampling Mode** you can set the timebase scale from 20 ps/div (on the fastest models) to 5 μ s/div in a 1-2-5-10 coarse sequence.

In **Roll Sampling Mode** you can set the timebase scale from 100 ms/div to 1000 s/div. Adjustable in a 1-2-5-10 coarse sequence.

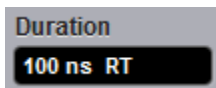

The horizontal scale you set, and the requirement that all waveforms fit within the 10 horizontal-division display, determines the horizontal duration of the window relative to any waveform, allowing you to scale it to contain a waveform edge, a cycle, or several cycles.

$$\text{Time Duration (seconds)} = 10 \text{ div (window size)} \times \text{Timebase Scale (sec/div)}$$

$$\text{Time Duration (seconds)} = \text{Sample Interval (seconds/sample)} \times \text{Record Length (samples)}$$

7.2.1.3 Sample Rate and Resolution

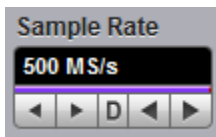

The **Sample Rate** control determines how often the waveform is sampled.

In **Real Time Sampling Mode** the sample rate can be set to a maximum of 500 MS/s. In **Random Equivalent Time Sampling Mode** the sample rate can be set to a maximum of 2.5 TS/s.

$$\text{Sample Interval (seconds/sample)} = \text{Resolution (sec/sample)} = 1/\text{Sample Rate (samples/sec)}$$

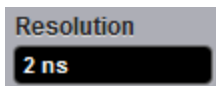

Resolution is the time interval between sample points taken during acquisition.

$$\text{Sample Interval (seconds/sample)} = \text{Resolution (sec/sample)} = 1/\text{Sample Rate (samples/sec)}$$

For real-time digitizers, the sample interval is the reciprocal of the sample rate. It has 2 ns minimum value.

For equivalent-time digitizers, the time interval between successive samples represents equivalent time, not real time. It has 0.4 ps minimum value.

7.2.1.4 Record Length

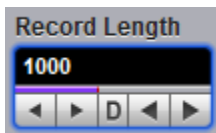

The number of samples that form a trace is called the record length. For example, if the horizontal (timebase) scale is set up as 10 ns/div, the total displayed sweep time is 100 ns. The more sampled data that is available for analysis or measurements, the greater the record length.

You can select record length with one of these methods:

- By using the **Record Length** control
- By using the [Pop-up Keypad](#)

For real-time sampling from 50 S/ch to 250 kS/ch for one channel, to 125 kS/ch for two channels, to 50 kS/ch for three and four channels.

For random equivalent time sampling record length can be selected from 500 S/ch to 250 kS/ch for one channel, to 125 kS/ch for two channels, to 50 kS/ch for three and four channels.

7.2.1.5 Delay

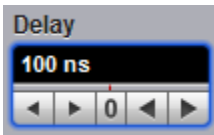

The **Delay** controls the time between the trigger event and the acquisition of data. For both real time and random equivalent time sampling mode delay can be changed from 0 to 4.28 s.

7.2.1.6 Trigger Position

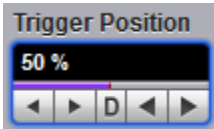

The adjustable feature trigger position defines where on the waveform record the trigger occurs. It lets you properly align and measure data within records. The part of the record that occurs before the trigger is the pre-trigger portion. The part that occurs after the trigger is the post-trigger portion. The amount of pre-trigger and post-trigger information available depends on the sweep speed selected and memory depth.

Displaying pre-trigger information can be valuable when troubleshooting. For example, if you are trying to find the cause of an unwanted glitch in your test circuit, it might trigger on the glitch and make the pretrigger period large enough to capture data before the glitch. By analyzing what happened before the glitch, you may uncover clues about its source.

7.2.2 Acquisition

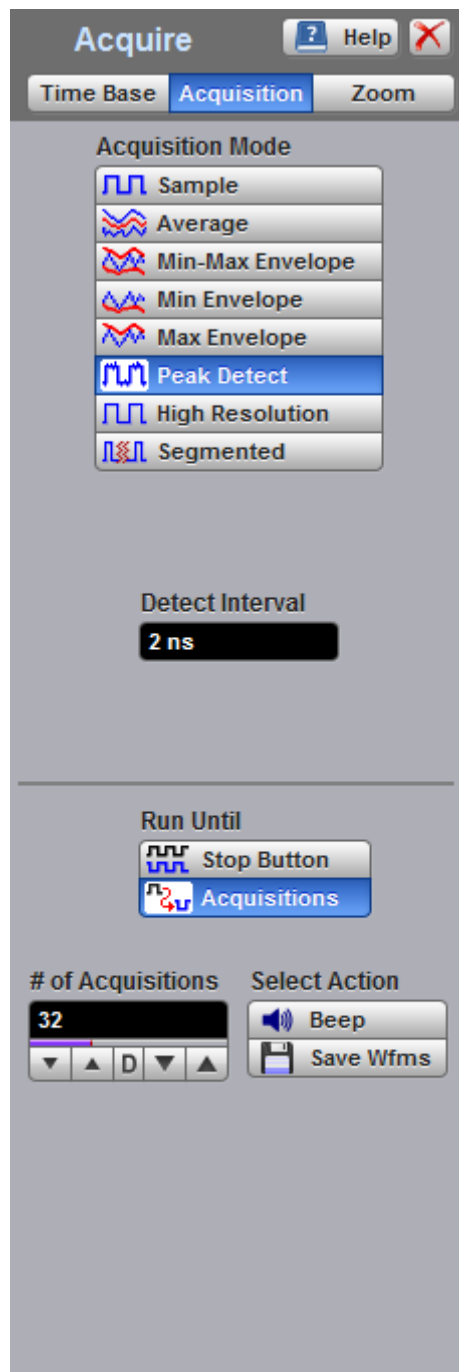

The Acquisition Menu

7.2.2.1 Acquisition Mode

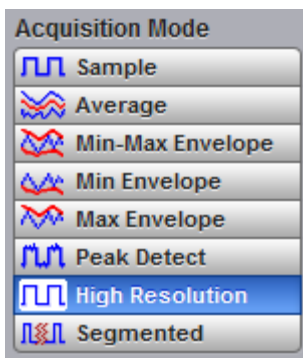

Acquisition Mode lets you choose how the oscilloscope will create points in the waveform record.

The PicoScope 9400 Series uses eight basic acquisition modes.

- **Sample** (default mode) - acquires one sample point per trigger and displays results without further processing. It is available in Real time, Random ET and Roll modes.
- **Average** - calculates the average values for each record point over many waveform records. It is available in Real time and Random ET modes.
- **Min-Max, Min and Max Envelope** - uses the highest and lowest samples across several waveform records. These are available in Real time and Random ET modes.
- **Peak Detect** - this mode alternates between saving the highest sample in one acquisition interval and the lowest sample in the next acquisition interval. It is available in Real time mode only.
- **High Resolution** - this mode averages all samples taken during an acquisition interval to create a record point. This average results in a higher-resolution, lower-bandwidth waveform. This mode only works with Real time mode.
- **Segmented** - acquires a number of captures, one for each trigger event, all stored in a single buffer. It is available in Real time mode only.

Acquisition modes do not affect the data sampling itself. However, they do affect the analysis of the sampling, and therefore the way the oscilloscope combines the samples into a data point value.

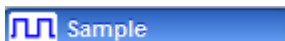

Sample

Sample acquisition mode

This is the default mode, which is useful for acquiring fast signals. The oscilloscope saves the samples during each acquisition interval (it is the time covered by the waveform record divided by the record length).

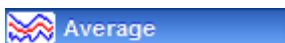

Average

Average acquisition mode

Pressing **Average** lets you acquire and display a waveform that is the combined result of several acquisitions. The oscilloscope acquires data as in the **Sample** mode and then averages it according to the number of acquisitions that you specify. Each point in a record is numerically averaged with the same point in all other records. This reduces the random noise of a displayed waveform and provides a cleaner display, improves resolution of the displayed waveform, and increases measurement repeatability, all due to a more stable displayed waveform. The noise sources can average to zero over time while the underlying waveform is preserved. The effective resolution of the displayed waveform increases as more acquisitions are averaged together, provided that the input waveform is repetitive and has a stable trigger point. However, averaging reduces the throughput of the instrument. Also, the waveform is less responsive to changes, especially when you select a high number of averages. The vertical resolution can be also improved by using averages.



Use the **Clear Display** button to reset the averaging process.

 Note that averaging is particularly useful for single-valued waveforms such as pulses or sine waves. Multi-valued waveforms, such as eye-diagrams, are not improved with averaging because the eye “collapses” to the average value between logic level one and logic level zero.

The PicoScope 9400 Series uses so-called stable averaging. This is the algorithm:

$$A_n = A_{n-1} + \frac{x_n - A_{n-1}}{2^k}$$

where:

- n - is the current acquisition's number
- A_n - is the current acquisition's cumulative average
- A_{n-1} - is the previous acquisition's cumulative average
- x_n - is the newly acquired sample's value
- k - is the number of averages

As the number of acquisitions increases, the number of averages k increases and the size of the correction term (2^{-k}) decreases. Although the display becomes less noisy after each acquisition, the first acquisition has the greatest effect, and succeeding acquisitions have less effect as the correction term becomes smaller. For example, a change that occurs during the second acquisition shows up on the screen much sooner than one that occurs during the sixteenth. Whenever you adjust a control that affects the display, the scope starts a new averaging sequence to ensure that you will see the change immediately.

Signal-to-Noise Improvement Ratio with Averaging

Selected Number of Averages	Signal-to-Noise Improvement Ratio	
	Linear	dB
2	1.41	3.0
4	1.98	5.9
8	2.75	8.8
16	3.84	11.7
32	5.24	14.6
64	7.51	17.5
128	10.60	20.5
256	14.90	23.4
512		

When you select the **Average** mode, you can enter the number of averages with the **Average N**

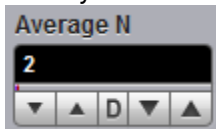

variable. The number of averages can be specified from 2 to 4096 in multiples of two by one of these methods:

- By using the **Average N** control
- By using the [Pop-up Keypad](#) for some specific settings

 The waveform is less responsive to changes if a large number of averages is specified.

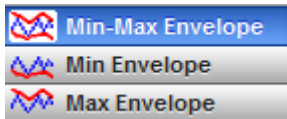

Min-Max, Min and Max Envelope acquisition modes

- **Min-Max Envelope** mode
- **Max Envelope** mode
- **Min Envelope** mode

Clicking one of the envelope radio buttons (**Min-Max Envelope**, **Max Envelope** or **Min Envelope**) lets you acquire and display a waveform showing the extreme values of several acquisitions over a period of time. Thus, the oscilloscope detects peaks. You can specify a number of acquisitions over which to accumulate and display the min/max data. The oscilloscope compares the min/max values from the current acquisition with those stored from previous acquisitions up to the specified number of acquisitions. An enveloped waveform then shows the maximum excursions of the individual waveform records. This often results in a thicker waveform trace that shows the variations of the signal. Use this mode to reveal the noise band around the signal.

Because it degrades the timing information in the data by a factor of 2, **Envelope** mode is typically not suitable for FFT analysis. In addition, this mode can obscure the statistical distribution of the samples that occurred between the minimum and maximum values. However, you can create a display of this distribution by using the persistence display modes to view only peak values sampled over a period of time.



The **Envelope** mode requires a stable trigger for time correlation.

Min-Max Envelope. This radio button tells the oscilloscope to acquire and display the variation of both extremes - maximum and minimum.

Max Envelope. This radio button tells the oscilloscope to acquire and display the variation of maximum values.

Min Envelope. This radio button tells the oscilloscope to acquire and display the variation of minimum values.

When you select **Min-Max Envelope**, **Max Envelope** or **Min Envelope** mode you can enter the number of



acquisitions with the **Envelope N** variable. The number of acquisitions can be specified from 2 to 4096 in multiples of two or continuously using one of these methods:

- By using the **Envelope N** spin box
- By using the [Pop-up Keypad](#)



Envelope and **Average** modes operate after the oscilloscope has taken two or more acquisitions. For example, each **Average** mode averages the corresponding data points from two or more waveforms, not the waveform as a whole. **Envelope** mode builds an envelope from the peak minimum and maximum values of each point on a succession of waveforms.

Side effect of averaging and enveloping. Averaging improves the accuracy of some software measurements, because the measurements are taken from averaged data. However, some measurements can be adversely affected by averaging or enveloping. For example, if you take a rise time measurement of a signal with horizontal jitter, the averaged trace will indicate an inaccurately slow reading. Be cautious when taking software measurements of averaged or enveloped traces. Use statistical measurements on the unaveraged signal to take an accurate rise time measurement on a signal with jitter.

 **Peak Detect**

Peak Detect acquisition mode

This mode alternates between saving the highest sample in one acquisition interval and the lowest sample in the next acquisition interval. This mode is available in Real time mode only.

 **High Resolution**

High Resolution acquisition mode

In **High Resolution** mode the oscilloscope creates a record point by averaging all samples taken during an acquisition interval. The results in a higher-resolution, lower-bandwidth waveform. This mode only works with real-time sampling. A key advantage of High Resolution mode is its potential for increasing vertical resolution regardless of the input signal. The table below indicates that you can obtain up to 16 significant bits with High Resolution mode.

Resolution	Maximum Sampling Rate	Bandwidth
12.5 bits	250 MS/s	110 MHz
13 bits	125 MS/s	55 MHz
13.5 bits	62.5 MS/s	27.5 MHz
14 bits	31.25 MS/s	13.8 MHz
14.5 bits	15.625 MS/s	6.9 MHz
15 bits	7.81 MS/s	3.4 MHz
15.5 bits	3.91 MS/s	1.7 MHz
16 bits	1.95 MS/s	0.85 MHz

 **Segmented**

Segmented mode

Available in **Real Time Timebase** mode only.

Segmented mode splits the capture memory into the specified number of parts, called *segments*. Each segment starts when a trigger event occurs and finishes when the segment is full. Each segment has its own timestamp, which records when the trigger occurred

The **# of Segments** control specifies the number of segments to collect. The number can be anything from 1 to **Max # Segments** (the latter being calculated by PicoSample 4 according to the capture settings):

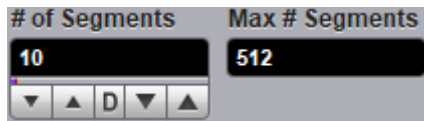

The **View Multiple Segments** control specifies how the segment data is displayed:

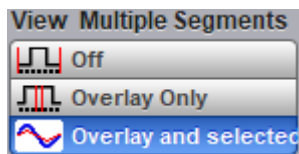

Off – Displays only the latest segment that was captured.

Overlay Only – Displays the specified range of segments from **First Segment** to **Last Segment** as a single overlay. The combined waveform is drawn as a heat map with rarely visited points shown in cool colors and frequently visited points in hot colors. The live waveform is drawn on top in the channel's normal color.

Overlay and selected – Displays the specified range of segments as in **Overlay Only** mode, with an additional layer showing the **Selected Segment**.

Find Segment..

The **Find Segment** button starts the **Segment Finder** utility. This is a binary search tool that helps you to find an anomalous waveform segment quickly by dividing the segment range in half repeatedly. On each iteration, you inspect the display and tell the utility whether or not the anomalous waveform feature (such as a glitch or dropout) is visible.

If you have 512 segments, for example, this utility enables you to find an anomaly in only 9 steps rather than an average of 256 steps if you searched through the segments one by one.

If the **Find Segment** button is greyed out, the oscilloscope is probably still capturing data. Press the **Stop** button and the **Find Segment** button should then be enabled.

Time Table..

The **Time Table** button displays a table of segment timestamps relative to the real-time clock. The table's three columns are:

Segment – The segment number.

Trigger Time, s – The time at which the segment was triggered.

d Trigger Time, s – The delta time between this segment and the previous one.

7.2.2.2 Run Until

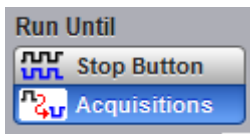

The **Run Until** control allows you to determine when the acquisition of data stops.

- **Stop Button.** If this is selected, you must press the [Stop](#) button to stop the acquisition of data.
- **Acquisitions.** If this is selected, acquisition is stopped when the specified number of acquisitions is reached. You can set this number using the [# of Acquisitions](#) control.

7.2.2.3 # of Acquisitions

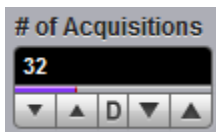

Sets the number of acquisitions. After the selected number of acquisitions is reached, the acquisition is stopped.

7.2.2.4 Action

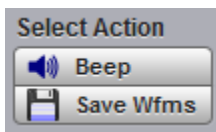

After the **Run** key is pressed, the oscilloscope makes the specified number of acquisitions, all of which will be saved to the memory. The **Action** control allows you to specify what the instrument does after acquisition is stopped. One of two actions can be selected.

Beep

Beep produces an audio tone.

Save Wfms

Save Wfms opens the **Save Waveform As** dialog, which allows you to choose one of three file formats for the saved waveform. These are:

- Binary format, with **.wfm** extension
- Verbose format, with **.txt** extension
- Y values format, with **.txty** extension

7.2.3 Zoom

The **Zoom** menu allows you to select one from four zoom areas, to zoom and position any of selected zoom area horizontally or vertically.

For more details see [Zoom Menu](#).

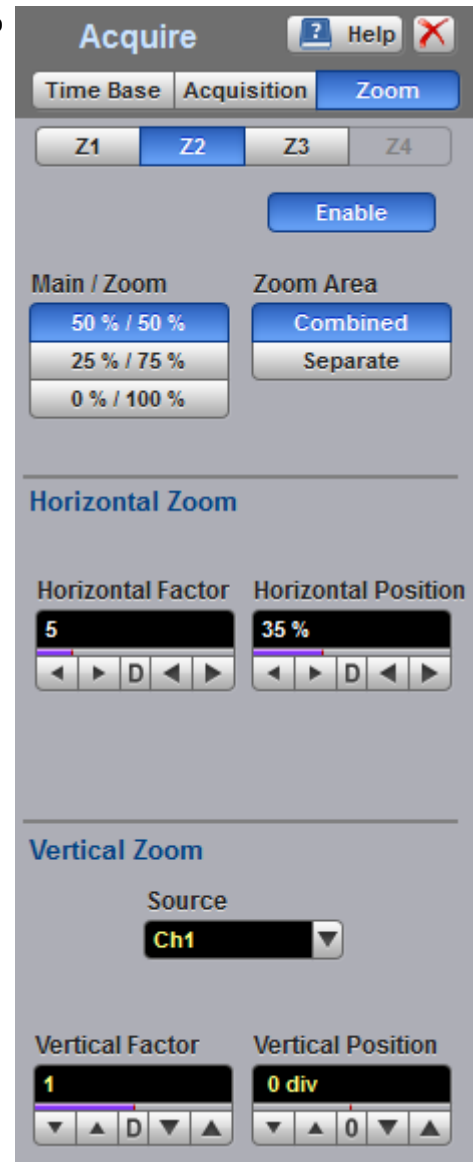

The Zoom Menu

7.3 Display Menu



The **Display** menu controls most of the features that determine how the acquired data is displayed on the screen. You can configure the PicoScope 9400 for persistence or color-graded display style, select the graticule settings, define the waveform display area for single or multiple waveform displays, and change the color of most of the items that are displayed on the screen.



The Display menu

7.3.1 Style

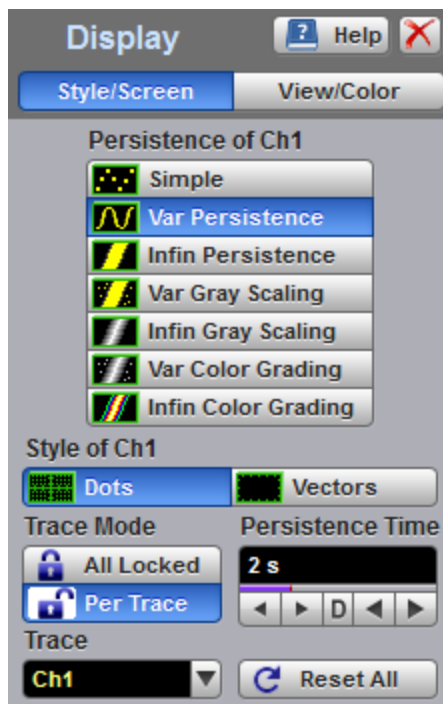

The Display Style menu

7.3.1.1 Persistence



The **Persistence** menu determines how the data is displayed. There are seven choices for drawing waveforms:

- **Simple.**
- **Variable Persistence.**
- **Infinite Persistence.**
- **Variable Gray Scaling.**
- **Infinite Gray Scaling.**
- **Variable Color Grading.**
- **Infinite Color Grading.**

Simple display

The **Simple** style displays waveforms without persistence: each new waveform record replaces the previously acquired record for a channel. Data points are plotted on the display as fast as possible. When the waveform record length is small, the throughput of the instrument is fast enough that you can use the **Vector** style without noticing much decrease in throughput.

Display Persistence

The **Persistence** function determines how long a data point is kept on the display before being erased. Normally, a waveform is displayed only for one trigger event. When the next trigger event occurs, the previous waveform is erased and the newly acquired waveform is drawn on the display. Persistence is a display memory function; therefore acquired waveforms are written only to display memory. Acquisition memory is where the current waveform data is stored. Therefore, only the last acquired waveform is held in acquisition memory. Display memory is what is seen on the display graticule.

Persistence style applies to all waveforms. Use display persistence to control how waveform data ages. By adding persistence, you can see a visual history of a waveform's acquisitions over time. Setting the persistence to minimum allows for easiest viewing of variations in the acquired waveforms. Setting the persistence to infinite allows for a complete view of everything measured in the waveform. For example, you can see the accumulated peak-to-peak noise of a waveform over time, which may appear significantly different than in only one acquisition. You can see timing jitter, the variance of the waveform from the trigger event, by accumulating acquisitions on the display. By adding persistence, viewing a waveform's extremes over time is much easier.

You can have averaging and persistence on at the same time because when averaging is on, the averaging is done before the data is sent to the display. Use the [Acquisition](#) menu to control averaging.

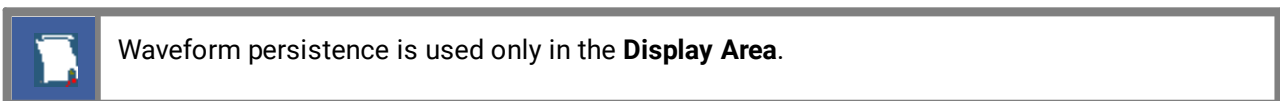



Use waveform persistence in the **Eye Diagram** and **Mask Test** menus. The **Eye Diagram** and **Mask Test** measurement algorithms are based on the statistical accumulation of the data.

The PicoScope 9400 Series uses two persistence settings:

- **Variable Persistence**
- **Infinite Persistence**

Variable Persistence

The **Variable Persistence** style accumulates the waveform-record points on screen and displays them for a specific time. The oldest waveform data continuously fades from the display as new waveform records are acquired.

By selecting the **Variable Persistence** display style, you can vary the persistence time from minimum of 100 ms to 10000 s. When the persistence is set to minimum, all data points are kept on the display for 100 ms. After 100 ms all the previous data points are erased from the display, and new data points are written to the display. The longer the persistence time, the longer each data point is left on the display before it is erased from the display. You can change the persistence time with the **Persistence Time** variable.

A minimum persistence setting is used when the input signal is changing and you need immediate feedback. You can use the minimum persistence mode to view the fastest display update rate. For example, if you are rapidly probing a source, you may find that more persistence is useful for observing long-term changes in a signal or observing signals with low repetition rates. More persistence is useful when you are observing long-term changes in the signal or low signal repetition rates.



If you are adjusting the amplitude or frequency of a signal source, you may find that more persistence (variable or infinite) is useful for observing long-term changes in a signal or observing signals with low repetition rates. If you are adjusting signal parameters, such as scale or delay, you will find that minimum persistence is useful due to the fast update rate.

When the waveform acquisition is stopped, the last acquired data points are left on the display.

If one of the following is changed when the instrument is in the variable persistence mode, the displayed waveform is redrawn and any accumulated waveforms are cleared:

- The **Clear** button is pressed
- An **Autoscale** button is executed
- A **Default Setup** button is executed
- The instrument is turned off

Infinite Persistence

When you select the **Infinite Persistence** display style, all the data points are kept on the display for an endless period of time, or until you change some control. Waveform data builds up as new data records are acquired. You can use infinite persistence for worst-case characterization of signal noise, jitter and drift, or to see a waveform's envelope, look for timing violations, and find infrequent events.

With infinite persistence, all sampled data points are left on the display until one of the following occurs:

- The **Clear** button is pressed
- An **Autoscale** button is executed
- A **Default Setup** button is executed
- The instrument is turned off

Gray Scaling

This mode is similar to persistence mode. The only difference is that the accumulated points are drawn in one color that is varied in saturation and luminosity (in other words, different shades of the same color). You can use the gray-scaling database with histograms, mask testing, statistical measurements, and eye diagrams. You can also use color grading to provide more visual information about the waveforms.

The **Gray Scaling** function uses a database the same size of the graticule area. Behind each pixel is a 16-bit counter. Each time a pixel is hit by data, the counter for that pixel is incremented. Each color used for the color grade mode represents a range of data counts. As the total count increases, the range of hits represented by each color also increases. The maximum count for each counter is 65 535.

There are five levels used in the gray-scaled mode. Each shade shows the number of hits per pixel over the graticule area, and represents a range of counts that depends on the total number of hits. As the total count increases, the range of hits represented by each shade also increases. The shades are fixed and cannot be changed.

You can use the gray-scaling persistence style to display waveforms that use the instrument measurement database. This database consists of all data samples displayed on the screen. The measurement database provides the data for the construction of histograms and performing mask tests.

If the gray-scaling persistence style is left active for a long period of time, the waveform will become saturated with the shades that represent the highest density of data counts.



Use gray-scaling in the **Eye Diagram** and **Mask Test** menus. The **Eye Diagram** and **Mask Test** measurement algorithms are based on the statistical accumulation of the data that the **Gray Scaling** mode uses internally.

Variable Gray Scaling

In the **Variable Gray Scaling** display style, the screen is not refreshed after every acquisition; instead, the screen is refreshed at a specified, selectable rate. You can vary the refresh time from minimum of 1 s to 200 s. You can change the refresh time with the **Refresh Time** variable.

If one of the following is changed when the instrument is in the **Variable Gray Scaling** display style, the displayed waveform is redrawn and any accumulated waveforms are cleared:

- The **Clear** button is pressed
- An **Autoscale** button is executed
- A **Default Setup** button is executed
- The instrument is turned off

Infinite Gray Scaling

When you select the **Infinite Gray Scaling** display style, all the data points are kept on the display. With the **Infinite Gray Scaling** display style, all sampled data points are left on the display until one of the following occurs:

- The **Clear** button is pressed
- An **Autoscale** button is executed
- A **Default Setup** button is executed
- The instrument is turned off

You can use infinite gray-scaling for worst-case characterization of signal noise, jitter and drift, or to see a waveform's envelope, look for timing violations, and find infrequent events.

Color Grading

This mode is similar to persistence mode. The only difference is that the accumulated points are color-graded (shaded with different colors) to indicate the density of the points, and a color-graded database is built. You can use the color-graded database with histograms, mask testing, statistical measurements, and eye diagrams. You can also use color grading to provide more visual information about the waveforms.

The **Color Grading** function uses a database the same size as the graticule area. Behind each pixel is a 16-bit counter. Each time a pixel is hit by data, the counter for that pixel is incremented. Each color used for the color grade mode represents a range of data counts. As the total count increases, the range of hits represented by each color also increases. The maximum count for each counter is 65 535.

There are five colors used in the color-graded display. Each color shows the number of hits per pixel over the graticule area, and represents a range of counts, which depends on the total number of hits. As the total count increases, the range of hits represented by each color also increases. The colors can be changed from the **Color Palette** menu.

You can use the color grade persistence mode to display waveforms that use the instrument measurement database. This database consists of all data samples displayed on the screen. The measurement database provides the data for the construction of histograms and performing mask tests.

If the color grade persistence style is left active for a long period of time, the waveform will become saturated with the color that represents the highest density of data counts. The **Color Palette** menu displays the color levels and the range of counts the color represents. Click the **View/Color** button to view the color levels.



Use gray-scaling in the **Eye Diagram** and **Mask Test** menus. The **Eye Diagram** and **Mask Test** measurement algorithms are based on the statistical accumulation of the data that the **Gray Scaling** mode uses internally.

The PicoScope 9400 Series has two color-grading settings:

- **Variable Color Grading**
- **Infinite Color Grading**

Variable Color Grading

In the **Variable Color Grading** display style the screen is not refreshed after every acquisition; instead, the screen is refreshed at a specified, selectable rate. You can vary the refresh time from minimum of 1 s to 200 s using the **Refresh Time** variable.

If one of the following is changed when the instrument is in the Variable Color Grading display style, the displayed waveform is redrawn and any accumulated waveforms are cleared:

- The **Clear** button is pressed
- An **Autoscale** button is executed
- A **Default Setup** button is executed
- The instrument is turned off

Infinite Color Grading

When you select the **Infinite Color Grading** display style, all the data points are kept on the display. With the **Infinite Color Grading** display style, all sampled data points are left on the display until one of the following occurs:

- The **Clear** button is pressed
- An **Autoscale** button is executed
- A **Default Setup** button is executed

- The instrument is turned off

You can use infinite color grading for worst-case characterization of signal noise, jitter and drift, and to see a waveform's envelope, look for timing violations, and find infrequent events.

7.3.1.2 Style



The **Style** menu determines how waveform dots are displayed. There are two choices: **Dots** or **Vectors**.

The **Dots** style displays waveforms with dots.

The **Vector** style draws a straight line through the data points on the display. This is also known as **Connect Waveform Dots**. The **Vector** style gives an analog look to a digitized waveform and makes it possible to see steep edges on waveforms such as square waves. If you use the **Vector** style the approximate unaliased oscilloscope bandwidth is:

$$\text{Bandwidth} = \text{Effective Sample Rate} / 10$$

In this configuration, a waveform can alias if its highest frequency component exceeds 1/10 the sample rate. On waveforms where there are only a few dots representing the acquired data points, such as when the record length is small, you may find it easier to have a sense of what the waveform looks like.

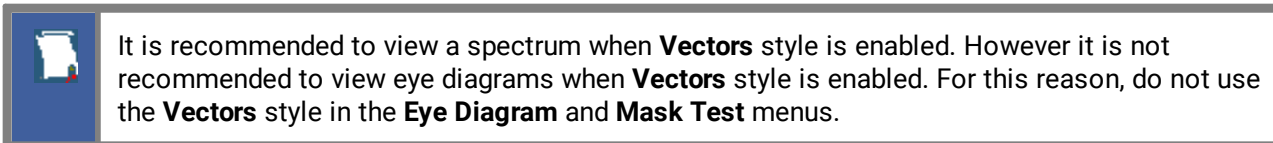

7.3.1.3 Persistence Time / Refresh Mode

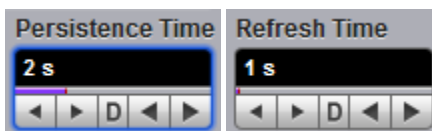

Persistence Time

The **Persistence Time** variable works when the **Variable Persistence** display is selected in the **Style** menu.

Persistence time is the amount of time for which a waveform sample appears on the display. In the **Variable Persistence** display style, a waveform sample point is displayed from 100 ms to 10000 s. The default setting is 2 s.

This mode most closely simulates the phosphorescent persistence of an analog scope. Use variable persistence to view infrequent events and rapidly changing waveforms and watch the evolution of the waveform.

Refresh Time

The **Refresh Time** variable works with both the **Variable Gray Scaling** and the **Variable Color Grading** display styles. It controls how often the screen is updated with new data. The range is 1 to 200 s.

7.3.1.4 Trace Mode

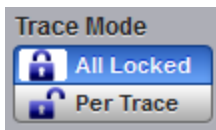

The PicoScope 9400 Series gives you the choice of constraining all input channels to the same display style, or setting these for each trace individually.

- **All Locked** Set the same display style for all traces.
- **Per Trace** Set up traces individually.

7.3.1.5 Trace

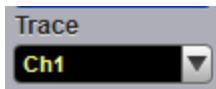

Selects a trace to set **Display Style**. Is active only when **Per Trace** is selected from the **Trace Mode**.

7.3.1.6 Reset All

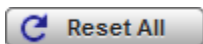

Click **Reset All** to return all traces to their default persistence settings.

7.3.2 Screen

The **Screen** menu lets you define the display area in different ways.

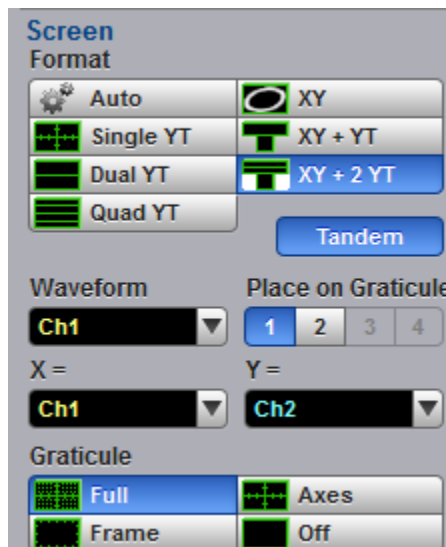

The Screen Menu

7.3.2.1 Format

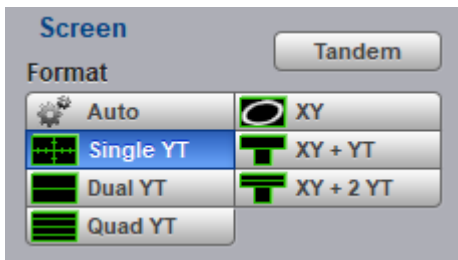

The **Format** menu determines how the instrument draws the waveforms on the display. The following formats are used in the PicoScope 9400 Series.

Auto

Auto automatically places, adds or deletes graticules as you select more or fewer waveforms to display.

Single YT

The **Single YT** format is the normal time (on the horizontal axis) versus voltage (on the vertical axis) format. The entire display area is one screen and any displayed waveforms are superimposed on top of each other.

Dual YT

The **Dual YT** format is the normal time (on the horizontal axis) versus voltage (on the vertical axis) format, but with the display area divided into two equal screens.

Quad YT

The **Quad YT** format is the normal time (on the horizontal axis) versus voltage (on the vertical axis) format, with the display area divided into four equal screens.

XY

The **XY** format displays voltages of two waveforms against each other, and draws the **Source 1** versus **Source 2** display of the two selected sources. **Source 1's** amplitude is plotted on the horizontal X axis and the **Source 2's** amplitude is plotted on the vertical Y axis.

XY+YT

The **XY + YT** format displays both **XY** and **YT** pictures. The **YT** format appears on the upper part of the screen, and the **XY** format on the lower part of the screen. All waveforms in the **YT** format area are superimposed on top of each other.

XY + 2 YT

The **XY + 2 YT** format displays both **YT** and **XY** pictures. The **YT** format appears on the upper part of the screen, and the **XY** format on the lower part of the screen. The **YT** format display area is divided into two equal screens.

You can use the **XY** formats to compare frequency and phase relationships between two signals. The **XY** format can also be used with transducers to display strain versus displacement, flow versus pressure, volts versus current, or voltage versus frequency.

7.3.2.2 Waveform

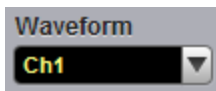

With the **Waveform** function you can set the waveform that will be placed on the graticule by the **Place on Graticule** menu.

The waveform source can be selected from:

- Channels
- Functions
- Waveform memories
- Spectra

Any waveform selected with the **Waveform** function is placed on the graticule chosen with the **Place on Graticule** menu.

7.3.2.3 Place on Graticule

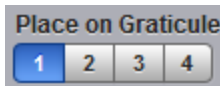

With the **Place on Graticule** menu you can place a waveform, selected by the **Waveform** function, on any possible graticule.

You can place any waveform selected as source to any graticule. For example, you can place the **M1** waveform memory on the fourth graticule, or the **F1** function on the first graticule.

7.3.2.4 X= and Y=



X=

The **X=** control selects the waveform source related to the horizontal X axis. You can set the **X=** source to:

- Channels
- Functions
- Waveform memories
- Spectra

Y=

The **Y=** selects the waveform source related to the vertical Y axis. You can set the **Y=** source to:

- Channels
- Functions
- Waveform memories
- Spectra

7.3.2.5 Graticule



The PicoScope 9400 Series has a 10 by 8 display graticule grid, which you can turn on or off. The **Graticule** menu selection is:

- **Full.** The **Full** background is a complete graticule with ten horizontal major divisions and eight vertical major divisions. Vertically one minor division is one-quarter of a major division; and horizontally, one minor division is one-fifth of a major division. There is also a cross-hair style measurement scale.
- **Axes.** Displays the outside border with an external measurement scale and an additional cross-hair style measurement scale.
- **Frame.** Displays the outside border with a measurement scale. Major and minor divisions are based on the vertical and horizontal measurement settings.
- **Off.** Turns the background graticule off. The displayed waveforms and waveform's information is not turned off.

7.3.3 View

The **View** menu turns on or off the different display areas of the GUI.

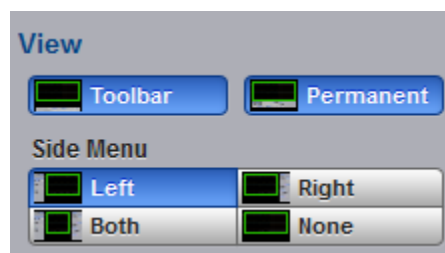

The View Menu

7.3.3.1 Toolbar

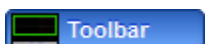

Turns on or off the display the **Toolbar**.

You can return the **Toolbar** to the **GUI** by clicking **View/Toolbar** in the **Main Menu**.

7.3.3.2 Permanent Controls

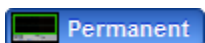

Permanent turns on or off the display of permanent controls.

You can return the permanent controls to the **GUI** by clicking **View/Permanent Controls** in the **Main Menu**.

7.3.3.3 Side Menu



Side Menu turns on or off the display of **Left Side Menu**, **Right Side Menu** or both **Side Menus**.

You can return any of the **Side Menus** to the **GUI** by clicking **View/Side Menu** in the **Main Menu**.

7.3.4 Color

The **Color** menu allows you to define the display colors and transparency of many display elements. For example, you can change the color of an input waveform channel for better visibility.

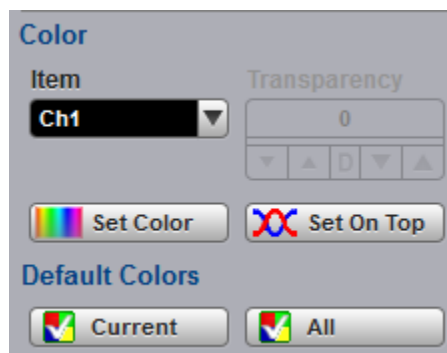

The Color Menu

7.3.4.1 Item

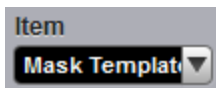

Item allows you to choose from the list of display elements. You can modify the color of the channels, functions, display memories, spectra, histogram, graticule, or screen. The color of the selected display element can be changed with the **Set Color** button.

7.3.4.2 Set Color



Clicking **Set Color** recalls the Windows **Color** dialog:

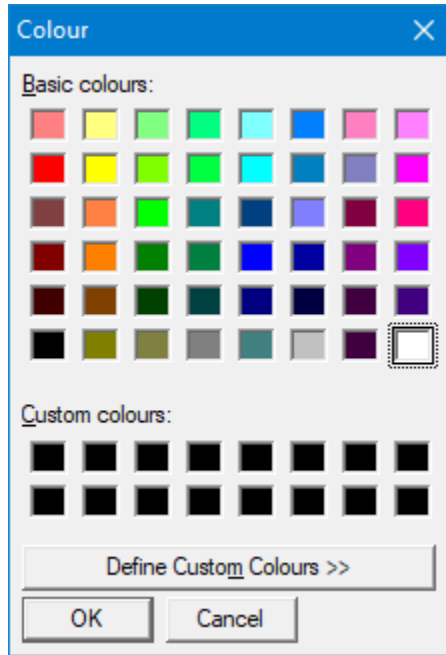

You can change the color of every item selected from the **Item** drop-down list box.

7.3.4.3 Set On Top

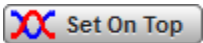

Click the **Set On Top** if you want to superimpose the display element selected from the **Item** list over all another display elements.

7.3.4.4 Transparency



You can change the transparency of several display elements selected from the **Item** menu. They are:

- **Histogram**
- **Mask**

The **Transparency** control increases or decreases the transparency effect.

7.3.4.5 Current

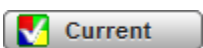

Clicking **Current** returns the selected display element to the factory default color.

7.3.4.6 All



Clicking **All** returns all display elements to the factory default colors.

7.3.5 Color Palette

The **Color Palette** menu has a list of five colors used in the color grade display.

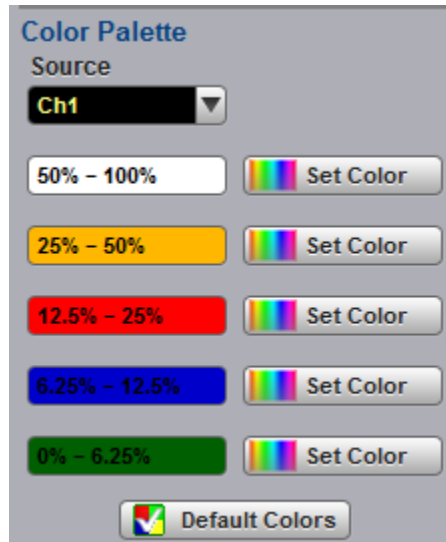

The Color Palette Menu

7.3.5.1 Source

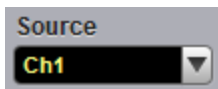

You may set the source for the color palette to any of the following:

- Channels
- Functions
- Waveform memories
- Spectra

7.3.5.2 Color Palette

The **Color Palette** menu defines the five colors used in the color grade display. The algorithm used in the PicoScope 9400 Series depends on the maximum number of hits for any pixel in the display. An example of the assignment of colors is shown in the table below. Maximum in the table represents the maximum number of hits in any bin, which for this algorithm must be at least 16.

A sample assignment of colors to hit density:

Hit density	Default color	Color
50% to 100%	White	50% – 100%
25% to 50%	Yellow	25% – 50%
12.5% to 25%	Rose	12.5% – 25%
6.25% to 12.5%	Light Blue	6.25% – 12.5%
0% to 6.25%	Green	0% – 6.25%

Click **Set Color**  **Set Color** to recall the Windows **Color** dialog:

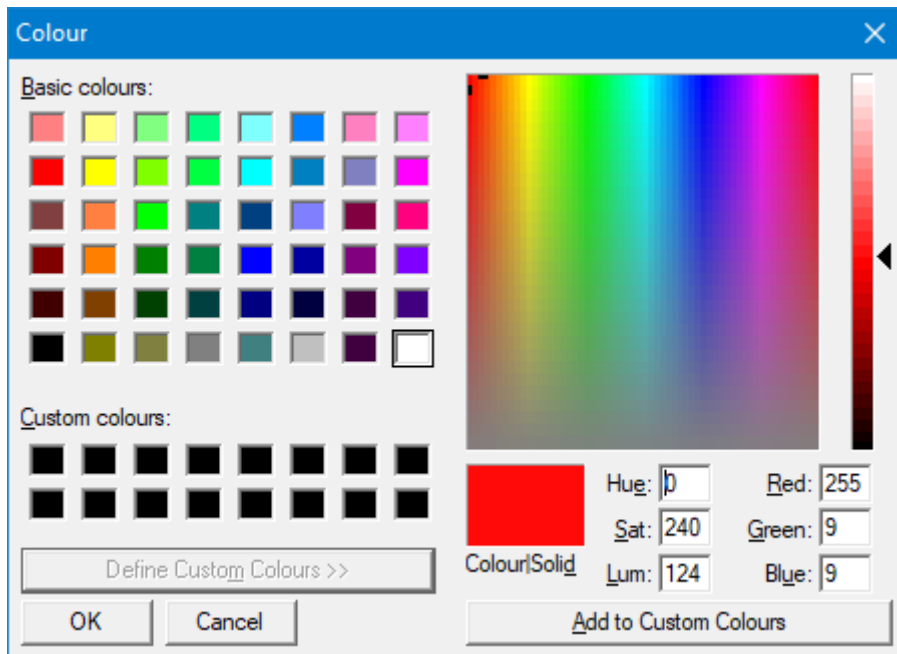

7.3.5.3 Default Colors

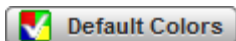

Clicking **Default Colors** returns all five colors used in the color-graded display to the factory default.

7.4 Eye Diagram Menu

Eye Diagram

The **Eye Diagram** menu allows you to perform eye diagram measurements.

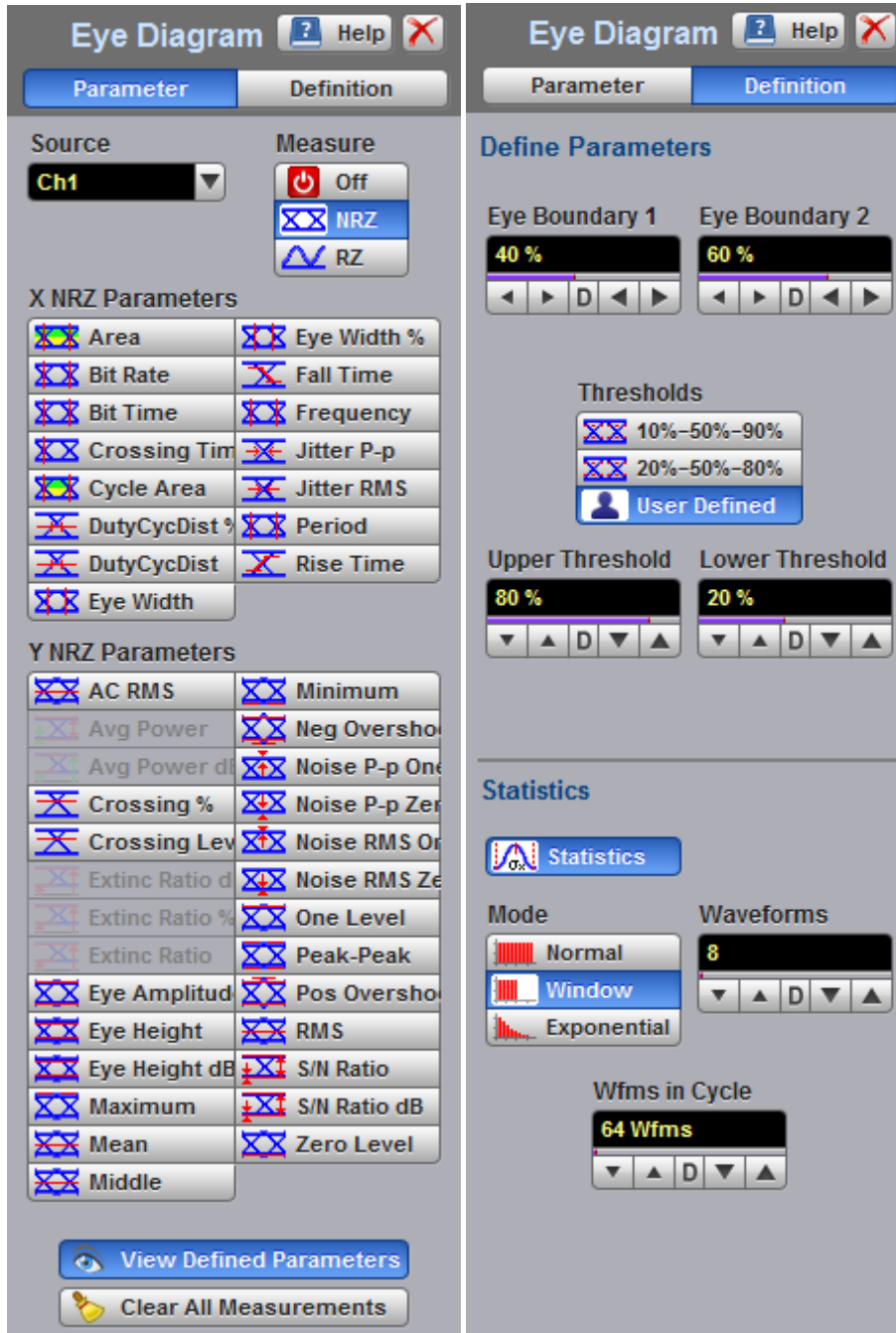

The Eye Diagram menu

The measurement algorithms for **Eye Parameters** will only work when an eye diagram, and not a pulse, is present on the screen.

Eye measurements are based on statistical data that is acquired and stored in the measurement database. The algorithms are dependent upon histogram means calculated from the measurement database. Therefore, if you want to perform eye measurements, it is necessary that you first produce an eye diagram by triggering the instrument with a synchronous clock signal. Measurements made on a pulse waveform while in the **Eye Diagram** menu will fail.

Once the **Eye Diagram** measure menu has been selected, the measurement database is enabled. This database consists of all data samples displayed on the screen. The measurement database provides the data for the construction of histograms, generation of mask tests, and a visual representation of the eye via the color-graded display mode.



Once you are in the **Eye Diagram** menu, perform an **Autoscale**. This will ensure that an optimum eye diagram is displayed on the graticule. An optimum eye diagram consists of a full display of the eye in addition to portions of the waveform preceding and following the eye.

Data is acquired, histograms are built, and absolute maximum and minimum voltage/power levels as well as relative maximum (one) and minimum (zero) voltage/power levels are determined. The crossing points of the eye are located, the threshold levels are calculated, and then, depending on the specific measurement(s) activated, the requested parametric measurements are calculated.

Eye measurements are made in a fashion similar to many of the automatic measurements built into the instruments such as **Rise** and **Fall Time**, **Peak-Peak**, and **Frequency**. Up to ten parametric measurements can be active whenever valid data exists. These measurements can include any of the eye measurements under the **X NRZ (RZ Eye) Parameters** and **Y NRZ (RZ Eye) Parameters** menus.

Eye measurements can be performed on a persistence or color-graded database.

7.4.1 Parameter

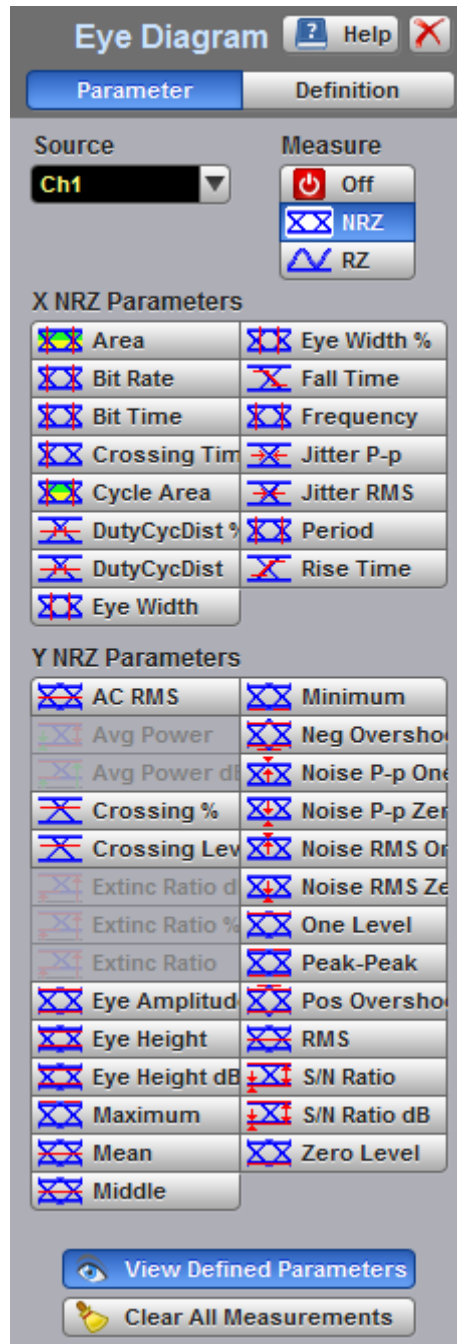

The Eye Diagram Parameter menu

7.4.1.1 Source

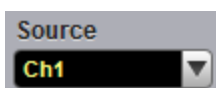

The **Source** control selects the source you are measuring. The measurement read-outs of parameters will have the same color as the selected source.

7.4.1.2 Measure



Off

Clicking the **Off** radio button stops running the test. The Eye Window, which has a green color, disappears.

The **Eye Boundaries** provide the time boundaries within which signal parameters for eye diagrams are measured.

NRZ

Clicking the **NRZ** radio button in the **Measure** menu starts the instrument calculating the **One Level, Zero Level, Left Crossing** and **Right Crossing** for NRZ types of signal. After the calculations are finished the **Eye Window**, which has a green color, will appear.

NRZ (Non-return to zero)
A type of signal coding that ensures, in any one bit period, that the signal is turned on for the entire duration of a logical one pulse and turned off (or nearly off) for the entire duration of a logical zero pulse.

RZ

Clicking the **RZ** radio button in the **Measure** menu starts the instrument calculating the **One Level, Zero Level, Left Crossing** and **Right Crossing** for RZ types of signal. After the calculations are finished the Eye Window, which has a green color, will appear.

RZ (Return to zero)
A type of signal coding that ensures, in any one bit period, that the signal is turned on for the first half of a logical one pulse and turned off (or nearly off) for the second half of the logical one pulse. As with NRZ coding, the signal is turned off (or nearly off) for the entire duration of a logical zero pulse.

Measurements Results

The instrument displays the results of eye diagram measurements in the **Measurement Area** of the GUI. These values are displayed on tabs.

	Current	Cycles/Wfms	Minimum	Maximum	Mean	Std Deviation
Bit Rate (Ch1)	1.249 GBit/s	7 / 476	1.248 GBit/s	1.249 GBit/s	1.248 GBit/s	506.9 kBit/s
Jitter RMS (Ch1)	10.41 ps	7 / 476	10.14 ps	10.54 ps	10.34 ps	130.7 fs
Crossing % (Ch1)	50.17 %	7 / 476	49.35 %	50.23 %	50.03 %	310.8 m%
Eye Amplitude (Ch1)	600 mV	7 / 476	599.9 mV	600 mV	600 mV	34.39 µV

The tabs only appear as the selected measurements are performed. For example, if you perform a **Bit Rate** measurement on channel 1, only this tab will appear on the display.

The measurement database and the graticule display will clear when you perform the following events:

- Switch between operating modes in the **Display** menu

- Change vertical and horizontal scale and position
- Click on the **Clear Display** button

The **Eye Diagram Measure tab** displays a maximum of ten measurements at one time. The measurements are listed in the order in which they were performed.

The **Measure tab** displays the following measurement statistics for each measurement:

- **Current** The current value measured in the measurement database.
- **Total Meas** The total number of acquired measurement cycles.
- **Minimum** The minimum current value measured in the measurement database.
- **Maximum** The maximum current value measured in the measurement database.



The measurement statistics reported will vary depending on the mode of operation selected.

7.4.1.3 X NRZ Eye Parameters

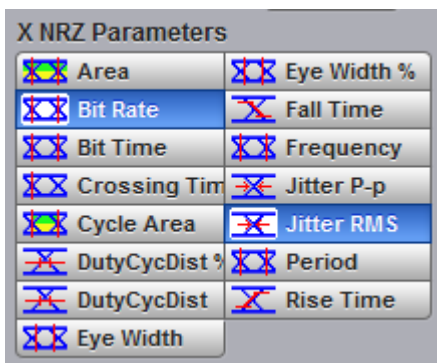

The list of **X NRZ Eye Parameters** includes fifteen eye parameters.



You can perform up to ten simultaneous measurements on one displayed waveform.

The measurement algorithms for **X NRZ Eye Parameters** will only work when an NRZ eye diagram, and not an RZ eye diagram or a pulse, is present on the screen. Eye measurements are based on statistical data that is acquired and stored in the measurement database. The algorithms are dependent upon histogram means calculated from the measurement database. Therefore, if you want to perform eye measurements, it is necessary that you first produce an eye diagram by triggering the instrument with a synchronous clock signal. Measurements made on an RZ eye diagram or a pulse waveform while in the **X NRZ Eye Parameters** menu will fail.



Area

NRZ Area

The **NRZ Area** is a measure of the area under the curve for the NRZ waveform within the full display window. The area measured above ground is positive; the area measured below ground is negative.

The **NRZ Area** is determined as follows:

$$NRZ_Area = \frac{\Delta t}{N} \sum_{n=1}^N VertPos(s_n)$$

over all N samples $s_1...N$ in the measured region (full display window) of duration Δt .

This measurement requires the use of a waveform database. When this measurement is turned on, it will automatically set the measurement system to use a waveform database if available.



Bit Rate

NRZ Bit Rate

NRZ Bit Rate is the inverse of bit time (1/bit time). The bit time is a measure of the horizontal opening of an eye diagram at the crossing points of the eye.

To compute bit time (bit period), the crossing points of the eye are first located. Then a vertically thin measurement window is placed horizontally through the crossing points. The data within this measurement window is analyzed. This measurement window is created to be extremely small so that the width of the crossing points is not affected by the rise time and fall time of the waveform.

Once the bit period has been determined, the inverse value is calculated to determine the bit rate.

$$NRZ\ Bit\ Rate = 1 / NRZ\ Bit\ Time$$

Also see **NRZ Bit Time**.

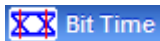

Bit Time

NRZ Bit Time

NRZ Bit Time is a measure of the horizontal opening of an eye diagram at the crossing points of the eye.

NRZ Bit Time can be determined as:

$$NRZ\ Bit\ Time = T_{cross2} - T_{cross1}$$

where T_{cross2} and T_{cross1} are the means of the histogram of the two consecutive eye crossings (**Right Crossing** and **Left Crossing**).

This measurement requires the use of a waveform database. When this measurement is turned on, it will automatically set the measurement system to use a waveform database if available.

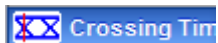

Crossing Time

NRZ Crossing Time

NRZ Crossing Time is a measure of the horizontal position of the leftmost eye crossing.

Data is sampled on a horizontal slice at the eye crossing, and the mean of the horizontal histogram returns the crossing time.

NRZ Crossing Time can be determined as:

$$NRZ\ Crossing\ Time = T_{cross1} + T_{delay}$$

This measurement requires the use of a waveform database. When this measurement is turned on, it will automatically set the measurement system to use a waveform database if available.

 **Cycle Area** **NRZ Cycle Area**

NRZ Cycle Area is a measure of the area under the curve for the first NRZ bit time within the measurement region. Area measured above ground is positive; area measured below ground is negative.

The **NRZ Cycle Area** is determined as follows:

$$NRZ_CycleArea = \frac{\Delta t}{N} \sum_{n=1}^N VertPos(s_n)$$

over all N samples $s_1 \dots s_N$ within the measured region (eye window) of duration Δt between **Left Crossings** and **Right Crossings**. Neither slope nor direction is configurable.

This measurement requires the use of a waveform database. When this measurement is turned on, it will automatically set the measurement system to use a waveform database if available.

 **DutyCycDist %**
 **DutyCycDist** **NRZ Duty Cycle Distortion % and NRZ Duty Cycle Distortion**

NRZ Duty Cycle Distortion is a measure of the time between the falling edge and the rising edge of the eye pattern at the middle threshold (50% level).

The instrument constructs a histogram that records the time at which the rising edge and falling edge cross the middle threshold. If the falling edge and the rising edge intersect precisely at the middle thresholds, there is no duty cycle distortion. **NRZ Duty Cycle Distortion** is measured by histogram analysis at the crossing points and middle threshold.



The algorithm for calculating **NRZ Duty Cycle Distortion** is dependent upon the edge that crosses the threshold first. Therefore, the falling edge may occur prior to the rising edge. Ideally, both the rising and falling edges intersect precisely at the 50% threshold level. That results in no duty cycle distortion.

NRZ Duty Cycle Distortion can be displayed in two formats: time or percent. In the time format (**DutCycDis s**), the actual time between the median falling edge and the median rising edge at the middle thresholds is determined. In the percentage format (**DutCycDis %**), the time difference is determined as a percentage of the full bit time.

The **NRZ Duty Cycle Distortion** is determined as follows:

$$NRZ_DutyCycleDistortion = Trise_{50\%} - Tfall_{50\%}$$

$$NRZ_DutyCycleDistortion = \frac{Trise_{50\%} - Tfall_{50\%}}{BitPeriod}$$

 **Eye Width**  **Eye Width %** **NRZ Eye Width and NRZ Eye Width %**

NRZ Eye Width is a measure of the horizontal opening of an eye diagram. Ideally, the eye width would be measured between the crossing points of the eye. A horizontal time histogram is constructed to determine the mean location at the crossing points, as well as statistical distribution of the crossing points. As would be expected, noise and jitter will cause a large variance in the location of the crossing points and result in the closure of the eye.

The eye width is determined using the time difference between the 3σ (standard deviation) points of the crossing point histograms (**Eye Width** measurement).

$$NRZ_EyeWidth = (T_{cross2} - 3\sigma_{cross2}) - (T_{cross1} - 3\sigma_{cross1})$$

You can choose to view eye width as a ratio of the time difference between the 3 σ points of the crossing point histograms relative to the time between adjacent crossing points (bit period). The eye width can then be expressed in percent of the bit period (**Eye Width %** measurement).

$$NRZ_EyeWidth_ \% = \frac{(T_{cross2} - 3\sigma_{cross2}) - (T_{cross1} - 3\sigma_{cross1})}{T_{cross2} - T_{cross1}}$$

Fall Time **NRZ Fall Time**

NRZ Fall Time is a measure of the mean transition time of the data on the downward slope of an eye diagram. The data crosses through the following three thresholds: the upper, middle, and lower thresholds, as well as through the eye crossing points.

A histogram is first constructed to find the mean location of the crossing points relative to the one level and zero level. Histograms are then constructed at each of the three threshold levels (for example, the 10%, 50%, and 90% points on the transition). The instrument analyzes each histogram to determine the histogram mean at which the data crosses the separate threshold levels.

Once the scanning of the waveform is complete, and the instrument has identified the mean location for each threshold crossed, then fall time can be computed.

$$NRZ\ Fall\ Time = (Time\ at\ the\ Lower\ Threshold\ Crossing) - (Time\ at\ the\ Upper\ Threshold\ Crossing)$$

The instrument has two standard threshold levels for which fall time may be measured. The default setting is between the 20% and 80% points on the transition, and the second is between the 10% and 90% points on the transition. The 20% to 80% transition is recommended for devices with significant pulse distortion. Also, user defined threshold levels can be selected. You can define the threshold settings that you want by going to the [Define Parameters/Thresholds](#) menu.



If the fall time relative to the time per division is a small value, the data acquired at the threshold levels on the falling edge will not yield accurate measurement results. (The falling edge will appear very steep on the display screen).

If the falling edge of your eye diagram is steep, increase the timebase (horizontal scale) on the display so that the falling edge covers at least half a graticule division. The instrument will be able to discern the data at the threshold levels, producing more accurate results.

Frequency **NRZ Frequency**

NRZ Frequency is defined as half of the inverse of the time interval between two consecutive eye crossing points (i.e. the reciprocal of the **Period**). It would be the frequency of a digital signal of a 0-1-0-1... stream.

The **NRZ Frequency** is determined as follows:

$$NRZ_Frequency = \frac{1}{2(T_{cross2} - T_{cross1})}$$

where T_{cross1} and T_{cross2} are the means of the histograms of the two crossings.

This measurement requires the use of a waveform database. When this measurement is turned on, it will automatically set the measurement system to use a waveform database if available.



NRZ Jitter peak-to peak and NRZ Jitter RMS

NRZ Jitter is a measurement of the time variance of the crossing points. Horizontal time histograms are constructed to determine the location of the crossing points. An iterative process is used to narrow the histogram window to precisely determine the crossing points and the variance. The measurement window is kept extremely small so that the width of the crossing points is not influenced by the rise time and fall time of the waveform. The amount of jitter on the waveform is directly related to the width of the crossing points.

NRZ Jitter can be displayed in one of two formats: peak-to-peak (**NRZ Jitter P-p** measurement) or RMS (**NRZ Jitter RMS** measurement). Both values are based on the standard deviation of the crossing point position.

NRZ Jitter peak-to peak is equal to the full width of the histogram at the eye crossing point:

$$\text{NRZ Jitter P-p} = 6\sigma (\text{crossing})$$

NRZ Jitter RMS is defined as one standard deviation from the histogram mean at the eye crossing point:

$$\text{NRZ Jitter RMS} = 1\sigma (\text{crossing})$$

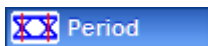

NRZ Period

NRZ Period is twice the time interval between two consecutive eye-crossing points. It would be the period of a digital signal of a 0-1-0-1... stream.

NRZ Period can be defined as:

$$\text{NRZ Period} = 2(T_{\text{cross}2} - T_{\text{cross}1}) = 2(\text{NRZ_BitTime})$$

where $T_{\text{cross}1}$ and $T_{\text{cross}2}$ are the means of the histograms of the two crossings of the eye diagram (**Right Crossing** and **Left Crossing**).

This measurement requires the use of a waveform database. When this measurement is turned on, it will automatically set the measurement system to use a waveform database if available.

Also see **NRZ Bit Time**.

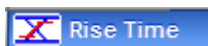

NRZ Rise Time

NRZ Rise Time is a measure of the mean transition time of the data on the upward slope of an eye diagram. The data crosses the lower, middle, and upper thresholds, as well as the eye crossing points.

A histogram is first constructed to find the mean location of the crossing points relative to the one level and zero level. Histograms are then constructed at each of the three threshold levels (for example, the 10%, 50%, and 90% points on the transition). The instrument analyzes each histogram to determine the histogram mean at which the data crosses the separate threshold levels.

Once the scanning of the waveform is complete, and the instrument has identified the mean location for each threshold crossed, then rise time can be computed.

$$\text{NRZ Rise Time} = (\text{Time at the Upper Threshold Crossing}) - (\text{Time at the Lower Threshold Crossing})$$

The instrument has two standard threshold levels for which fall time may be measured. The default setting is from the 10% to the 90% point on the transition, and the second is from the 20% to the 80% point on the transition. The 20% to 80% transition is recommended for devices with significant pulse distortion. Also, user defined threshold levels can be selected. You can define the threshold settings that you want by going to the [Define Parameters/Thresholds](#) menus.



If the rise time relative to the time per division is a small value, the data acquired at the threshold levels on the falling edge will not yield accurate measurement results. (The rising edge will appear very steep on the display screen).

If the rising edge of your eye diagram is steep, increase the timebase (horizontal scale) on the display so that the rising edge covers at least half a graticule division. The instrument will be able to discern the data at the threshold levels, producing more accurate results.

7.4.1.4 Y NRZ Eye Parameters

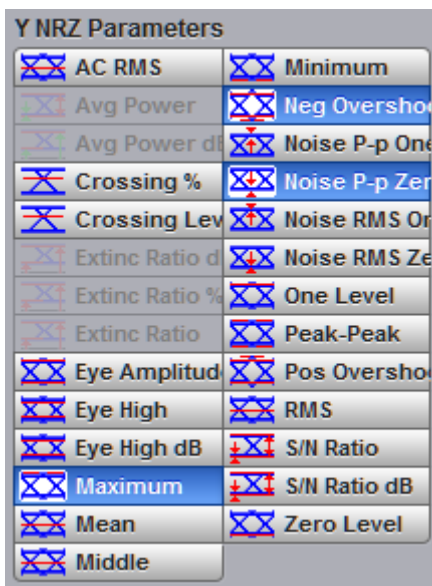

The list of **Y NRZ Eye Parameters** includes twenty-seven eye parameters.



You can perform up to ten simultaneous measurements on one displayed waveform.

The measurement algorithms for **Y NRZ Eye Parameters** will only work when an NRZ eye diagram, and not an RZ eye diagram or a pulse, is present on the screen. Eye measurements are based on statistical data that is acquired and stored in the measurement database. The algorithms are dependent upon histogram means calculated from the measurement database. Therefore, if you want to perform eye measurements, it is necessary that you first produce an eye diagram by triggering the instrument with a synchronous clock signal. Measurements made on an RZ eye diagram or a pulse waveform while in the **X NRZ Eye Parameters** menu will fail.

AC RMS **NRZ AC RMS**

NRZ AC RMS is a measure of the root mean square amplitude, minus the DC component, of the selected waveform.

The **NRZ AC RMS** is defined as follows:

$$NRZ_AC_RMS = \sqrt{\frac{\sum_{i=1}^N \{[VertPos(s_n) - mean[VertPos(s)]]^2\}}{N}}$$

where s is the set of N samples $s_1...N$ within the measured region.

When this measurement is turned on, it will automatically set the measurement system to use a waveform database if available.



NRZ Crossing percentage and NRZ Crossing Level

NRZ Crossing percentage is a measure of the location of the eye crossing points relative to the separation between the **One Level** (V_{one}) and the **Zero Level** (V_{zero}).

Typically, it is desirable to have the crossing points located midway between V_{one} and V_{zero} . In this case the crossing percentage would be 50% according to the following formula:

$$NRZ\ Crossing\ percentage = 100 (V_{cross} - V_{zero}) / (V_{one} - V_{zero})$$

NRZ Crossing Level is the mean signal level at the eye crossing point:

$$NRZ\ Crossing\ Level = mean[VertPos(s)]$$

where s is the set of samples in a vertical slice at the eye crossing point.

V_{cross} is the more prevalent vertical location or amplitude of the crossing points. A horizontal histogram over the entire display is used to determine the time location of the crossing points. Narrow vertical histograms are then used to determine the vertical location of V_{cross} . The mean derived from the horizontal and vertical histogram results in V_{cross} .

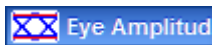

NRZ Eye Amplitude

NRZ Eye Amplitude is the difference between the logic 1 level and the logic 0 level histogram mean values of an eye diagram.

A histogram is constructed using the sampled portion of the eye diagram within the eye window. This histogram is composed of data points from the upper and lower halves of the eye diagram. The instrument analyzes the histogram and determines the mean values of the logic 1 and logic 0 levels.

The eye amplitude is determined as follows:

$$NRZ\ Eye\ Amplitude = One\ Level - Zero\ Level$$

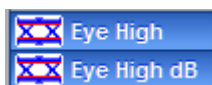

NRZ Eye Height and NRZ Eye Height dB

NRZ Eye Height is a measurement of the vertical opening of an eye diagram. An ideal eye opening would be measured from the one level to the zero level. However, noise on the eye will cause the eye to close. The eye height measurement determines eye closure due to noise.

Similarly to the extinction ratio measurements, a vertical histogram is calculated on the data. V_{one} and the high-level distribution are determined, and similar patterns are determined for the low levels. The V_{one} and V_{zero} levels are the relative means of the histograms. The noise is measured through the histograms as three standard deviations (σ) from both the one level and zero level into the eye opening.

The eye height can be defined in one of the two following formats:

$$NRZ_EyeHeight = (V_{one} - 3\sigma_{one}) - (V_{zero} + 3\sigma_{zero})$$

$$NRZ_EyeHeight(dB) = -10 \log_{10} \frac{(V_{zero} + 3\sigma_{zero})}{(V_{one} - 3\sigma_{one})}$$

Maximum **NRZ Maximum**

NRZ Maximum is a measure of the maximum vertical value of the waveform that is sampled within the eye window.

The NRZ maximum eye amplitude is determined as follows:

$$NRZ\ Maximum = \max[VertPos(s)]$$

where s is the set of samples within the eye window.

When this measurement is turned on, it will automatically set the measurement system to use a waveform database if available.

Mean **NRZ Mean**

NRZ Mean is a measure of the arithmetic mean of the selected waveform within the eye window.

The NRZ mean is determined as follows:

$$NRZ_Mean = \text{mean}[VertPos(s)] = \frac{1}{N} \sum_{i=1}^N VertPos(s_i)$$

over all samples $s_1 \dots N$ within the eye window.

When this measurement is turned on, it will automatically set the measurement system to use a waveform database if available.

Middle **NRZ Middle**

NRZ Middle is a measure of the middle level between the maximum and minimum vertical values of the eye window.

The NRZ middle is determined as follows:

$$NRZ\ Mid = (Max + Min) / 2$$

where Max and Min are the maximum and minimum measurements. See also **NRZ Max** and **NRZ Min**.

When this measurement is turned on, it will automatically set the measurement system to use a waveform database if available.

Minimum **NRZ Minimum**

NRZ Minimum is a measure of the minimum vertical value of the selected waveform of the eye window.

The NRZ minimum eye amplitude is determined as follows:

$$NRZ\ Minimum = \max[VertPos(s)]$$

where s is the set of samples within the eye window.

When this measurement is turned on, it will automatically set the measurement system to use a waveform database if available.

Neg Overshoot **NRZ Negative Overshoot**

NRZ Negative Overshoot is a measure of the ratio of the minimum value of the measured signal to its amplitude, expressed as a percentage. The waveform is scanned for the minimum value within the eye window, while the amplitude is measured in the **Eye Aperture**.

The NRZ Negative Overshoot is determined as follows:

$$NRZ_NegativeOvershoot = \frac{V_{zero} - V_{min}}{V_{one} - V_{zero}} \times 100$$

where V_{min} is the signal minimum, and V_{one} and V_{zero} are the logical 1 and 0 levels.

When this measurement is turned on, it will automatically set the measurement system to use a waveform database if available.

Noise P-p One Noise P-p Zero **NRZ Noise P-p One and NRZ Noise P-p Zero**

NRZ Noise P-p One is a measurement of the maximum range of the amplitude variance sampled within a fixed-width vertical slice located at the center of the **Eye Aperture** at the **One Level**.

NRZ Noise P-p Zero is a measurement of the maximum range of the amplitude variance sampled within a fixed-width vertical slice located at the center of the **Eye Aperture** at the **Zero Level**.

NRZ Noise P-p One is determined as follows:

$$NRZ\ Noise\ P-p\ One = One\ P-p$$

NRZ Noise P-p Zero is determined as follows:

$$NRZ\ Noise\ P-p\ Zero = Zero\ P-p$$

This measurement requires the use of a waveform database. When this measurement is turned on, it will automatically set the measurement system to use a waveform database if available.

Noise RMS One Noise RMS Zero **NRZ Noise RMS One and NRZ Noise RMS Zero**

NRZ Noise RMS is a measurement of the unit standard deviation of the amplitude variance sampled within a fixed-width vertical slice located at the center of the **Eye Aperture** at the **High** (logical 1) or **Low** (logical 0) levels.

$$NRZ\ RMS = High\ \sigma$$

$$NRZ\ RMS = Low\ \sigma$$

The **Eye Aperture** is adjustable and defaults to 20% of the NRZ bit time. This measurement requires the use of a waveform database. When this measurement is turned on, it will automatically set the measurement system to use a waveform database if available.

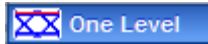

NRZ One Level

NRZ One Level is a measure of the mean value of the logical 1 of an eye diagram.

A histogram is constructed using the sampled portion of the eye diagram within the eye window. This histogram is composed of data points from only the upper half of the eye diagram. The instrument analyzes the histogram and determines histogram mean.

The **One Level** is determined as follows:

$$NRZ\ One\ Level = Histogram\ Mean$$

All data at the zero level is disregarded.



The standard deviation that is reported on the instrument display as part of the measurement results is derived from the statistical analysis of the one level measurement result. It is not the same as the standard deviation derived from the histogram analysis of the signal.

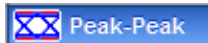

NRZ Peak-Peak

NRZ Peak-Peak is a measure of the difference between the maximum and minimum vertical values of the selected waveform within the eye window.

The **NRZ Peak-Peak** is determined as follows:

$$NRZ\ Peak-Peak = Max - Min$$

where *Max* and *Min* are the maximum and minimum measurements. See also **NRZ Max** and **NRZ Min**.

When this measurement is turned on, it will automatically set the measurement system to use a waveform database if available.

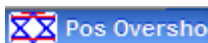

NRZ Positive Overshoot

NRZ Positive Overshoot is a measure of the ratio of the maximum value of the measured signal to its amplitude, expressed as a percentage. The waveform is scanned for the maximum value within the eye window, while the amplitude is measured in the **Eye Aperture**.

The **NRZ Positive Overshoot** is determined as follows:

$$NRZ_PositiveOvershoot = \frac{V_{max} - V_{one}}{V_{one} - V_{zero}} \times 100$$

where V_{max} is the signal maximum, and V_{one} and V_{zero} are the logical 1 and 0 levels.

When this measurement is turned on, it will automatically set the measurement system to use a waveform database if available.



NRZ RMS is a measure of the true root mean square amplitude of the selected waveform within the eye window.

The **NRZ RMS** is determined as follows:

$$NRZ_RMS = \sqrt{\frac{\sum_{n=1}^N [VertPos(s_n)]^2}{N}}$$

over all N samples within the measured region; i.e., one standard deviation of the amplitude, i.e., RMS amplitude.

When this measurement is turned on, it will automatically set the measurement system to use a waveform database if available.

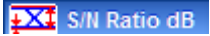

NRZ Signal to Noise and NRZ Signal to Noise dB

NRZ Signal to Noise is a ratio of the signal difference between one level and zero level relative to the noise present at both levels. Signal to Noise is similar in construction to a Q-factor measurement. However, noise levels contributed by the instrument cannot be removed, and therefore a slightly pessimistic Q-factor measurement may result.

To define the signal, histograms are constructed using the sampled portions of the eye diagram within the eye window boundaries. One histogram is composed of data points from only the upper half of the eye diagram (one level). The second histogram is composed of data points from the lower half of the eye (zero level). The instrument analyzes the histograms and determines the histogram means and standard deviations. The noise is defined as 1σ (standard deviation) of the histogram at the one and zero levels.

The RZ Signal to Noise is determined as follows:

$$NRZ_Signal_to_Noise_Ratio = \frac{V_{one} - V_{zero}}{\sigma_{one} + \sigma_{zero}}$$



This measurement does not remove the effect of noise generated by the instrument. If the noise on the signal being tested is of a magnitude similar to that of the instrument or smaller, the signal-to-noise measurement error will be significant.

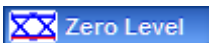

NRZ Zero Level

NRZ Zero Level is a measure of the mean value of the logical 0 of an eye diagram.

A histogram is constructed using the sampled portion of the eye diagram within the eye window. This histogram is composed of data points from only the lower half of the eye diagram. The instrument analyzes the histogram and determines histogram mean.

The **RZ Zero Level** is determined as follows:

NRZ Zero Level = Histogram Mean

All data at the one level is disregarded.



The standard deviation that is reported on the instrument display as part of the measurement results is derived from the statistical analysis of the zero level measurement result. It is not the same as the standard deviation derived from the histogram analysis of the signal.

7.4.1.5 X RZ Eye Parameters

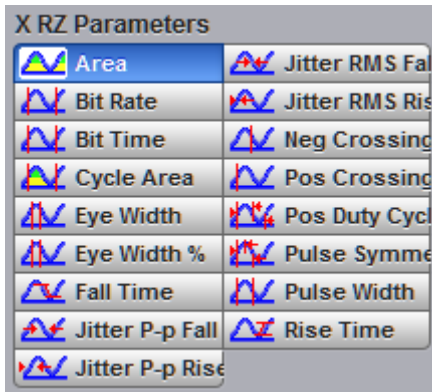

The list of **X RZ Eye Parameters** includes seventeen eye parameters.



You can perform up to ten simultaneous measurements on one displayed waveform.

The measurement algorithms for **X RZ Eye Parameters** will only work when an RZ eye diagram, and not an NRZ eye diagram or a pulse, is present on the screen. Eye measurements are based on statistical data that is acquired and stored in the measurement database. The algorithms are dependent upon histogram means calculated from the measurement database. Therefore, if you want to perform eye measurements, you must first produce an eye diagram by triggering the instrument with a synchronous clock signal. Measurements made on an NRZ eye diagram or a pulse waveform while in the **X RZ Eye Parameters** menu will fail.

 Area

RZ Area

RZ Area is a measure of the area under the curve for the RZ waveform within the full display window. Area measured above ground is positive; area measured below ground is negative.

The **RZ Area** is determined as follows:

$$RZ_Area = \frac{\Delta t}{N} \sum_{n=1}^N VertPos(s_n)$$

over all N samples $s_1...N$ within the measured region (full display window) of duration Δt .

This measurement requires the use of a waveform database. When this measurement is turned on, it will automatically set the measurement system to use a waveform database if available.

 Bit Rate

RZ Bit Rate

The **RZ Bit Rate** is a measure of the inverse of the bit time (1/bit time or 1/period) of the RZ eye rising edges. The bit time is a measure of the time between the 50% rising edges of two consecutive eyes.

To compute bit time (period), the 50% heights of consecutive eyes are first determined. Then a vertically thin measurement window is placed horizontally through the 50% levels. The data within this measurement window is analyzed. The measurement window is created to be extremely small so that the measurement is not affected by the fall or rise time of the waveforms.

Once the bit period has been determined, the inverse value is calculated to determine the RZ bit rate:

$$RZ_BitRate = \frac{1}{RZ_BitTime} = \frac{1}{2(T_{RightCross} - T_{LeftCross})}$$

where $T_{RightCross}$ and $T_{LeftCross}$ are the mean of the histogram of the two consecutive crossings on the rising slope at the mid-reference level.

See also **RZ Bit Time**.



Bit Time

RZ Bit Time

The **RZ Bit Time** is a measure of the time interval between two consecutive rising edges. The crossing times are computed as the mean of the histogram of the data slice at the mid-reference level.

The **RZ Bit Time** is determined as follows:

$$RZ_BitTime = T_{RightCross} - T_{LeftCross}$$

where $T_{RightCross}$ and $T_{LeftCross}$ are the mean of the histogram of the two consecutive crossings on the rising slope at the mid-reference level.

This measurement requires the use of a waveform database. When this measurement is turned on, it will automatically set the measurement system to use a waveform database if available.

RZ Bit Time also is called **RZ Bit Period**.



Cycle Area

RZ Cycle Area

RZ Cycle Area is a measure of the area under the curve for the RZ waveform within the eye window. Area measured above ground is positive; area measured below ground is negative.

The **RZ Cycle Area** is determined as follows:

$$RZ_CycleArea = \frac{\Delta t}{N} \sum_{n=1}^N VertPos(s_n)$$

over all N samples $s_1...N$ in the measured region (eye window) of duration Δt between two consecutive edges of the rising slope at the **Mid** reference level.

This measurement requires the use of a waveform database. When this measurement is turned on, it will automatically set the measurement system to use a waveform database if available.



Eye Width



Eye Width %

RZ Eye Width

RZ Eye Width is a measure of the horizontal opening of an RZ eye diagram. The amount of jitter or noise that may appear on the waveform is measured to determine the actual horizontal opening of the eye.

To compute eye width, the 50% height of the eye is first determined. Then a vertically thin measurement window is placed horizontally through the 50% levels, and the data within this measurement window is analyzed. This measurement window is created to be extremely small so that the measurement is not affected by the rise time and fall time of the waveform.

The RZ eye width is determined using the time difference between the 3σ (standard deviation) points of the 50% level histograms.

$$RZ_EyeWidth = (T_{Fall50\%} - 3\sigma) - (T_{Rise50\%} - 3\sigma)$$

The RZ eye width can also be expressed as the ratio of the 3σ time difference between edges to the bit time (bit period) of the eye pulses:

$$RZ_EyeWidth_% = \frac{(T_{Fall50\%} - 3\sigma) - (T_{Rise50\%} + 3\sigma)}{BitTime}$$

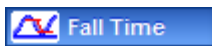

RZ Fall Time

RZ Fall Time is a measure of the mean transition time of the data on the downward slope of an RZ eye diagram. The data crosses through the following three thresholds: upper, middle, and lower.

A histogram is first constructed to find the mean locations of the eye one level and zero level. Histograms are then constructed at each of the three threshold levels (for example, the 20%, 50%, and 80% points on the transition). The instrument analyzes each histogram to determine the histogram mean at which the data crosses the separate threshold levels. Once the scanning of the waveform is complete, and the instrument has identified the mean location for each threshold crossed, then fall time can be computed.

$$RZ\ Fall\ Time = (Time\ at\ Lower\ Threshold\ Crossing) - (Time\ at\ Upper\ Threshold\ Crossing)$$

The default setting for the threshold levels is the 20% to 80% points on the transition. These levels give more consistent results for eyes with distortion at the top or bottom. You can define the threshold settings that you want in the [Define Parameters](#) menu.



If the fall time relative to the time/division is a small value, the data acquired at the threshold levels on the falling edge will not yield accurate measurement results. (The falling edge will appear very steep on the display screen).

If the falling edge of your eye diagram is steep, increase the timebase (horizontal scale) on the display so that the falling edge covers at least half a graticule division. The instrument will be able to discern the data at the threshold levels, producing more accurate results.



RZ Jitter P-p, Fall and RZ Jitter RMS, Fall

RZ Jitter P-p, Fall and **RZ Jitter RMS, Fall** are the measures of signal instability relative to its ideal position in time.

To compute jitter peak-to-peak, the standard deviation is measured at a 50% level of the first measurable falling edge. The measurement window is kept extremely small so that the width at the 50% level is not influenced by the slope of the waveform. The histograms are then analyzed to determine the amount of RMS jitter, which is defined as 1σ (standard deviation) from the histogram mean.

The RZ peak-to-peak jitter is the full width of the histogram at the eye 50% level:

$$RZ \text{ Jitter } P\text{-}p, \text{ Fall} = 6\sigma \text{ (crossing)}$$

The RZ RMS jitter is defined as one standard deviation from the histogram mean at the eye crossing point:

$$RZ \text{ Jitter } RMS, \text{ Fall} = 1\sigma \text{ (crossing)}$$



RZ Jitter P-p, Rise and RZ Jitter RMS, Rise

RZ Jitter P-p, Rise and **RZ Jitter RMS, Rise** are the measures of signal instability relative to its ideal position in time.

To compute jitter peak-to-peak, the standard deviation is measured at a 50% level of the left measurable rising edge. The measurement window is kept extremely small so that the width at the 50% level is not influenced by the slope of the waveform. The histograms are then analyzed to determine the amount of RMS jitter, which is defined as 1σ (standard deviation) from the histogram mean.

The RZ peak-to-peak jitter is the full width of the histogram at the eye 50% level:

$$RZ \text{ Jitter } P\text{-}p, \text{ Rise} = 6\sigma \text{ (crossing)}$$

The RZ RMS jitter is defined as one standard deviation from the histogram mean at the eye crossing point:

$$RZ \text{ Jitter } RMS, \text{ Rise} = 1\sigma \text{ (crossing)}$$



RZ Negative Crossing

RZ Negative Crossing is a measure of the time of a negative crossing, defined as the mean of the histogram of the data sampled at the 50% reference level.

The **RZ Negative Crossing** is determined as follows:

$$RZ \text{ Negative Crossing} = T_{CrossNeg}$$

where $T_{CrossNeg}$ is the mean of the histogram of a negative crossing.

This measurement requires the use of a waveform database. When this measurement is turned on, it will automatically set the measurement system to use a waveform database if available.



RZ Positive Crossing

RZ Positive Crossing is a measure of the time of a left positive crossing, defined as the mean of the histogram of the data sampled at the 50% reference level.

The **RZ Positive Crossing** is determined as follows:

$$RZ \text{ Positive Crossing} = T_{CrossPos}$$

where $T_{CrossPos}$ is the mean of the histogram of a positive crossing.

This measurement requires the use of a waveform database. When this measurement is turned on, it will automatically set the measurement system to use a waveform database if available.

 **Pos Duty Cyc** **RZ Positive Duty Cycle**

RZ Positive Duty Cycle is a measure of the ratio of the RZ positive pulse width to the RZ bit time.

The RZ Positive Duty Cycle is determined as follows:

$$RZ_DutyCycle = \frac{T_{Fall50\%} - T_{Rise50\%}}{T_{Fall50\%} + T_{Rise50\%}} = \frac{RZ_PositivePulseWidth}{RZ_BitTime}$$

Where $T_{Rise50\%}$, $T_{Fall50\%}$ and $T_{2Rise50\%}$ are the mean of the histogram of the first three consecutive crossings at the 50% reference level.

This measurement requires the use of a waveform database. When this measurement is turned on, it will automatically set the measurement system to use a waveform database if available.

 **Pulse Symme** **RZ Pulse Symmetry**

RZ Pulse Symmetry measures to what extent the RZ pulse is symmetrical around the peak at the 50% reference level. The pulse peak is the center of the interval, sized to **Eye Aperture**, which yields the maximum mean vertical value.

The **RZ Pulse Symmetry (%)** is determined as follows:

$$RZ_PulseSymmetry, \% = 100 \frac{T_{Peak} - T_{Rise50\%}}{T_{Fall50\%} - T_{Rise50\%}}$$

where $T_{Rise50\%}$ and $T_{Fall50\%}$ are the time crossings of the RZ pulse of the 50% reference level, and T_{Peak} is the time coordinate of the pulse peak.

This measurement requires the use of a waveform database. When this measurement is turned on, it will automatically set the measurement system to use a waveform database if available.

 **Pulse Width** **RZ Pulse Width**

RZ Pulse Width is the time measured between histogram means of the 50% rising and 50% falling edges of an RZ eye diagram.

The pulse width is determined as follows:

$$RZ\ Pulse\ Width = T_{Fall50\%} - T_{Rise50\%}$$

where $T_{Fall50\%}$ and $T_{Rise50\%}$ are the time crossings of the RZ pulse at the 50% reference level.

This measurement requires the use of a waveform database. When this measurement is turned on, it will automatically set the measurement system to use a waveform database if available.

 **Rise Time** **RZ Rise Time**

RZ Rise Time is a measure of the mean transition time of the data on the upward slope of an RZ eye diagram. The data crosses through the lower, middle, and upper thresholds.

A histogram is first constructed to find the mean locations of the eye one level and zero level. Histograms are then constructed at each of the three threshold levels (for example, the 20%, 50%, and 80% points on the transition). The instrument analyzes each histogram to determine the histogram mean at which the data crosses the separate threshold levels. Once the scanning of the waveform is complete, and the instrument has identified the mean location for each threshold crossed, then fall time can be computed:

$$\text{RZ Rise Time} = (\text{Time at the Upper Threshold Crossing}) - (\text{Time at the Lower Threshold Crossing})$$

The default setting for the threshold levels is between the 20% and 80% points on the transition. These levels give more consistent results for eyes with distortion at the top or bottom. You can define the threshold settings that you want in the [Define Parameters](#) menu.



If the rise time relative to the time per division is a small value, the data acquired at the threshold levels on the falling edge will not yield accurate measurement results. (The rising edge will appear very steep on the display screen).

If the rising edge of your eye diagram is steep, increase the timebase (horizontal scale) on the display so that the rising edge covers at least half a graticule division. The instrument will be able to discern the data at the threshold levels, producing more accurate results.

7.4.1.6 Y RZ Eye Parameters

Y RZ Parameters	
AC RMS	Maximum
Avg Power	Mean
Avg Power d	Middle
Contrast Ratio	Minimum
Contrast Ratio	Noise P-p One
Contrast Ratio	Noise P-p Zer
Extinction Rat	Noise RMS Or
Extinct Ratio d	Noise RMS Ze
Extinct Ratio %	One Level
Eye Amplitud	Peak-Peak
Eye High	RMS
Eye High dB	S/N
Eye Opening	Zero Level

The list of **Y RZ Eye Parameters** includes twenty-six eye parameters.



You can perform up to ten simultaneous measurements on one displayed waveform.

The measurement algorithms for **Y RZ Eye Parameters** will only work when an RZ eye diagram, and not an NRZ eye diagram or a pulse, is present on the screen. Eye measurements are based on statistical data that is acquired and stored in the measurement database. The algorithms depend upon histogram means calculated from the measurement database. Therefore, if you want to perform eye measurements, it is necessary that you first produce an eye diagram by triggering the instrument with a synchronous clock signal. Measurements made on NRZ eye diagram or a pulse waveform while in the **X RZ Eye Parameters** menu will fail.

AC RMS **RZ AC RMS**

RZ AC RMS is a measure of the root mean square amplitude, minus the DC component, of the waveform within the eye window.

The **RZ AC RMS** is determined as follows:

$$RZ_AC_RMS = \sqrt{\frac{\sum_{i=1}^N \langle [VertPos(s_n) - mean[VertPos(s)]]^2 \rangle}{N}}$$

where S is the set of N samples $s_1...N$ within the measured region.

This measurement requires the use of a waveform database. When this measurement is turned on, it will automatically set the measurement system to use a waveform database if available.

Contrast Ratio Contrast Ratio Contrast Ratio **RZ Contrast Ratio**

RZ Contrast Ratio is a measure of the ratio of the one level at the centre of the eye diagram to the one level (after removal of the zero level contribution) found midway between eye diagram peaks. This measurement indicates how well the logic 1 levels return to the logic zero level. Like the RZ extinction ratio measurement, contrast ratio relies on determining and removing the dark level components from the measurement calculation. In order to perform an accurate contrast ratio measurement, you should first perform an extinction ratio calibration in order to minimize the dark level contribution.

RZ Contrast Ratio also is called **RZ Suppression Ratio**.

RZ Contrast Ratio measurement is made in a section of the eye referred to as the **Eye Boundaries**, and at the centre of the zero level between pulses. The default value for **RZ Eye Boundaries** is the central 5% p-p of the Bit Time, or 47.5% (**Eye Boundary 1**) and 52.5% (**Eye Boundary 2**).

Histograms are constructed using the sampled portions of the eye diagram within the eye window boundaries, and within equivalent eye window boundaries positioned between eye diagram peaks. The one level histogram mean is composed of data points taken from the upper half of the eye window located within the eye diagram, the zero level histogram is composed of data points taken from the lower half of the eye window located within the eye diagram, and the remaining histogram is composed of data points taken from the eye window located between peaks. The instrument analyzes the histogram data, removes the zero level data from the between peaks histogram, then determines the ratio of the one level mean and the one level mean between peaks.

The accuracy of the contrast ratio measurement can be affected by offsets, including the dark level, generated within the instrument electronics, typically following the photodiode. When these offsets occur, they add to the incoming signal. This will change the values of the one and zero levels. When the contrast ratio measurement is computed, the result may appear much smaller or larger than the true value, depending on the value of the offset. To minimize contrast ratio measurement errors due to offsets, an extinction ratio calibration is recommended. This procedure allows the instrument to identify any internal signals present and remove them during the contrast ratio calculations. After the calibration is performed, a more accurate contrast ratio measurement can be executed.

With a valid extinction ratio calibration, the contrast ratio measurement can be computed and displayed in one of the three following formats:

$$NRZ_ContrastRatio = \frac{OneLevel - DarkLevel}{OneLevel(between_peaks) - DarkLevel}$$

$$NRZ_ContrastRatio(dB) = 10 \log_{10} \left[\frac{OneLevel - DarkLevel}{OneLevel(between_peaks) - DarkLevel} \right]$$

$$NRZ_ContrastRatio(\%) = \frac{OneLevel(between_peaks) - DarkLevel}{OneLevel - DarkLevel} \times 100$$

where: *One Level* = One level histogram mean at eye window, *One Level (between peaks)* = Histogram mean calculated from subtraction of zero level histogram from the between peaks histogram (see figure below).



Eye Amplitude RZ Eye Amplitude

RZ Eye Amplitude is a measure of the difference between the logic 1 level and the logic 0 level histogram mean values of an RZ eye diagram. It differs from eye height in that it does not account for the noise on the signal.

RZ Eye Amplitude measurement is made in a section of the eye referred to as the **Eye Boundaries**, and at the centre of the zero level between pulses. The default value for **RZ Eye Boundaries** is the central 5% p-p of the **Bit Time**, or 47.5% (**Eye Boundary 1**) and 52.5% (**Eye Boundary 2**).

A histogram is constructed using the sampled portion of the eye diagram within the eye window. This histogram is composed of data points from the upper and lower halves of the eye diagram. The instrument analyzes the histogram and determines the mean values of the logic 1 and logic 0 levels.

The eye amplitude is determined as follows:

$$RZ\ Eye\ Amplitude = One\ Level - Zero\ Level$$



Eye High



Eye High dB

RZ Eye Height

RZ Eye Height is a measure of the vertical opening of an RZ eye diagram. An ideal eye opening would be measured from the one level to the zero level, but noise on the eye causes the eye to close. The eye height measurement determines eye closure due to noise.

RZ Eye High measurement is made in a section of the eye referred to as the **Eye Boundaries**, and at the centre of the zero level between pulses. The default value for **RZ Eye Boundaries** is the central 5% p-p of the **Bit Time**, or 47.5% (**Eye Boundary 1**) and 52.5% (**Eye Boundary 2**).

In order to make an accurate RZ eye height measurement, histograms are constructed to characterize both the one and zero levels and their noise levels within the eye window boundaries. The one and zero levels are the relative means of the histograms. The noise is measured through the histograms as three standard deviations (σ) from both the one level and zero level into the eye opening.

The eye height is determined as follows:

$$RZ_EyeHeight = (OneLevel - 3\sigma_{one}) - (ZeroLevel + 3\sigma_{zero})$$

$$RZ_EyeHeight(dB) = -10\log_{10} \frac{(ZeroLevel + 3\sigma_{zero})}{(OneLevel - 3\sigma_{one})}$$

Eye Opening **RZ Eye Opening Factor**

RZ Eye Opening Factor is similar to eye height. It measures the actual eye opening relative to an ideal noise-free eye. While the eye height measurement uses 3σ for the noise contribution, the eye opening measurement uses 1σ .

The **RZ Eye Opening Factor** measurement is made in a section of the eye referred to as the **Eye Boundaries**, and at the centre of the zero level between pulses. The default value for **RZ Eye Boundaries** is the central 5% p-p of the **Bit Time**, or 47.5% (**Eye Boundary 1**) and 52.5% (**Eye Boundary 2**).

The eye opening factor is determined as follows:

$$RZ_EyeOpeningFactor = \frac{(OneLevel - \sigma_{one}) - (ZeroLevel + \sigma_{zero})}{OneLevel - ZeroLevel}$$

Maximum **RZ Maximum**

RZ Maximum is a measure of the maximum vertical value of the waveform that is sampled within the eye window.

The RZ maximum eye amplitude is determined as follows:

$$RZ\ Maximum = \max[VertPos(s)]$$

where s is the set of samples within the eye window.

When this measurement is turned on, it automatically sets the measurement system to use a waveform database if available.

Mean **RZ Mean**

RZ Mean is a measure of the arithmetic mean of the waveform that is sampled within the eye window.

The **RZ Mean** is determined as follows:

$$RZ_Mean = \text{mean}[VertPos(s)] = \frac{1}{N} \sum_{i=1}^N VertPos(s_i)$$

over all samples $s_i \dots N$ within the eye window.

When this measurement is turned on, it automatically sets the measurement system to use a waveform database if available.

 **RZ Middle**

RZ Middle is a measure of the middle level between the **Max** and **Min** vertical values of the waveform that is sampled within the eye window.

The **RZ Middle** is determined as follows:

$$RZ\ Mid = (Max + Min) / 2$$

where *Max* and *Min* are the maximum and minimum measurements.

When this measurement is turned on, it automatically sets the measurement system to use a waveform database if available.

 **RZ Minimum**

RZ Minimum is a measure of the minimum vertical value of the waveform that is sampled within the eye window.

The RZ minimum eye amplitude is determined as follows:

$$RZ\ Minimum = \max[VertPos(s)]$$

where *s* is the set of samples in the measured region. Minimum has no settable references.

When this measurement is turned on, it automatically sets the measurement system to use a waveform database if available.

 **RZ Noise P-p, One**
 **RZ Noise P-p, Zero**

RZ Noise P-p, One is a measure of the maximum range of the data distribution sampled within a fixed **RZ Eye Boundaries** slice located at the center of the **Eye Aperture** at the **One Level**.

RZ Noise P-p, Zero is a measure of the maximum range of the data distribution sampled within a fixed **RZ Eye Boundaries** slice located at the center of the **Eye Aperture** at the **Zero Level**.

The **RZ Noise P-p** is determined as follows:

$$RZ_Noise, P-p = \max[VertPos(s)] - \min[VertPos(s)]$$

where *s* is the set of samples within a fixed width vertical slice located at the center of the eye aperture at either the **High** or the **Low** level (settable: **RZ Noise P-p, One**, and **RZ Noise P-p, Zero**).

The **RZ Noise P-p, One** and **RZ Noise P-p, Zero** measurements are made in a section of the eye referred to as the **Eye Boundaries**, and at the centre of the zero level between pulses. The default value for **RZ Eye Boundaries** is the central 5% p-p of the **Bit Time**, or 47.5% (**Eye Boundary 1**) and 52.5% (**Eye Boundary 2**).

This measurement requires the use of a waveform database. When this measurement is turned on, it automatically sets the measurement system to use a waveform database if available.

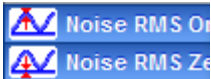

NRZ Noise RMS

NRZ Noise RMS is a measurement of the single standard deviation of the data distribution sampled within a fixed-width vertical slice located at the center of the **Eye Aperture** at the **High** (logical 1) or **Low** (logical 0) levels.

The **RZ Noise RMS** is determined as follows:

$$RZ\ RMS = High\ \sigma$$

$$RZ\ RMS = Low\ \sigma$$

The **Eye Aperture** is adjustable and defaults to 5% of the RZ pulse width. The **High** or **Low** selection for noise control in the **Measurement Setup** dialog instructs the measurement to be performed on the logical 1 or 0 levels.

This measurement requires the use of a waveform database. When this measurement is turned on, it automatically sets the measurement system to use a waveform database if available.

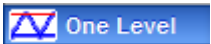

RZ One Level

RZ One Level is a measure of the mean value found at the peak of the eye diagram logical 1.

The **RZ One Level** measurement is made in a section of the eye referred to as the **Eye Boundaries**, and at the centre of the zero level between pulses. The default value for **RZ Eye Boundaries** is the central 5% p-p of the **Bit Time**, or 47.5% (**Eye Boundary 1**) and 52.5% (**Eye Boundary 2**).

A histogram is constructed using the sampled portion of the eye diagram within the eye window. This histogram is composed of data points from only the upper half of the eye diagram. The instrument analyzes the histogram and determines the histogram mean.

The **RZ One Level** is determined as follows:

$$RZ\ One\ Level = Histogram\ Mean$$

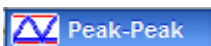

RZ Peak-Peak

RZ Peak-Peak is a measure of the difference between the maximum and minimum vertical values of the waveform.

The **RZ Peak-Peak** is determined as follows:

$$RZ\ Peak-Peak = Max - Min$$

where *Max* and *Min* are the maximum and minimum measurements.

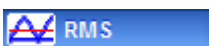

RZ RMS

RZ RMS is a measure of the true root mean square of the waveform that is sampled within the eye window.

The **RZ RMS** is determined as follows:

$$RZ_RMS = \sqrt{\frac{\sum_{n=1}^N [VertPos(s_n)]^2}{N}}$$

which is the RMS amplitude over all N samples $s_1 \dots s_N$ within the measured region (eye window); or one standard deviation of the amplitude.

When this measurement is turned on, it automatically sets the measurement system to use a waveform database if available.



RZ Signal to Noise

RZ Signal to Noise is a measure of the ratio of the signal difference between one level and zero level relative to the noise present at both levels. Signal-to-noise is similar in construction to a Q-factor measurement. However, noise levels contributed by the instrument cannot be removed, and therefore a slightly pessimistic **Q-factor** measurement may result.

RZ Signal to Noise ratio is computed as:

$$RZ_Signal_to_Noise_Ratio = \frac{OneLevel - ZeroLevel}{\sigma_{one} + \sigma_{zero}}$$

The **RZ One Level** and **Zero Level** measurements are made in a section of the eye referred to as the **Eye Boundaries**, and at the centre of the zero level between pulses. The default value for **RZ Eye Boundaries** is the central 5% p-p of the **Bit Time**, or 47.5% (**Eye Boundary 1**) and 52.5% (**Eye Boundary 2**).

To define the signal, histograms are constructed using the sampled portions of the eye diagram within the eye window boundaries. One histogram is composed of data points from only the upper half of the eye diagram (one level), and the second histogram is composed of data points from the lower half of the eye (zero level). The instrument analyzes the histograms and determines the histogram means and standard deviations. The noise is defined as 1σ (standard deviation) from the histogram means for the one and zero levels.



RZ Zero Level

RZ Zero Level is a measure of the mean value of the logical 0 at a time position found directly below the peak of the eye diagram logical 1.

The **RZ Zero Level** measurement is made in a section of the eye referred to as the **Eye Boundaries**, and at the centre of the zero level between pulses. The default value for **RZ Eye Boundaries** is the central 5% p-p of the **Bit Time**, or 47.5% (**Eye Boundary 1**) and 52.5% (**Eye Boundary 2**).

A histogram is constructed using the sampled portion of the eye diagram within the eye window. This histogram is composed of data points from only the upper half of the eye diagram. The instrument analyzes the histogram and determines the histogram mean.

The **RZ Zero Level** is determined as follows:

$$RZ\ Zero\ Level = Histogram\ Mean$$

7.4.1.7 View Define Parameters



Setting **View Define Parameters** to **On** gives you a visual indicator of the calculation of the **Eye Window** placement. The **Eye Window** is green.

Setting the control to **Off** makes the **Eye Window** disappear.

7.4.1.8 Clear All Measurements



Clicking **Clear All Measurements** removes all measurement results from the **Measurement Area** located at the bottom of the oscilloscope display.

7.4.2 Definition

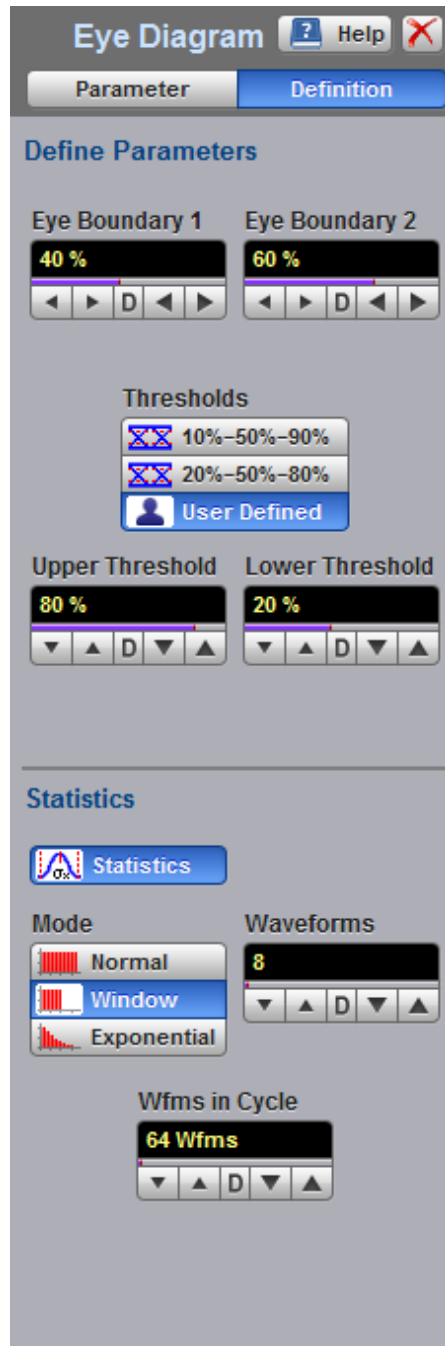

The Measurement Definition Menu

7.4.2.1 Define Parameters

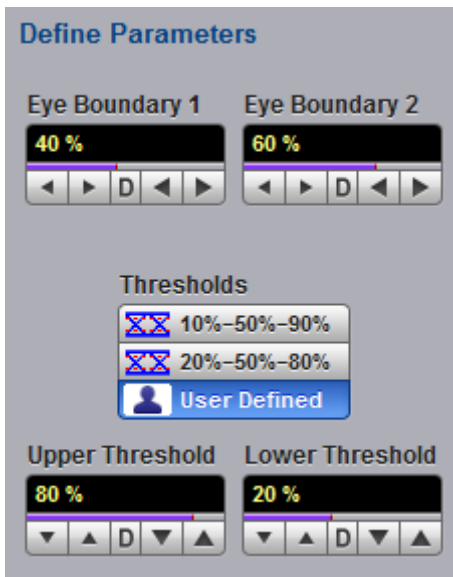

The **Define Parameters** menu sets the measurement points (boundaries and thresholds) where the automatic measurements are made. The menu influences the measurement algorithm by allowing you to use the standard measurement points, or customize the measurements with user-defined selections.

7.4.2.1.1 Eye Boundary 1 and Eye Boundary 2

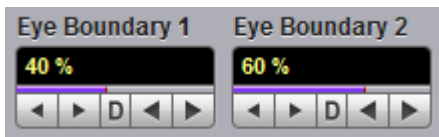

The **Eye Boundary 1** (left boundary) and the **Eye Boundary 2** (right boundary) variables set the time for the eye boundaries. These settings determine what horizontal portion of the eye will be used to generate histograms for eye diagram amplitude measurements. Both boundaries directly determine **One Level** and **Zero Level** values. You can use the instrument's default values of 40% and 60% for NRZ eye diagrams, and 47.5% and 52.5% for RZ eye diagrams, or you can enter the values you want for the boundaries.

Eye Boundary 1 allows you to set the percentage time for the left eye boundary, while **Eye Boundary 2** allows you to set the percentage time for the right eye boundary.

7.4.2.1.2 Thresholds

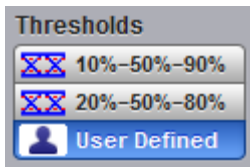

The **Thresholds** menu sets the upper, middle, and lower measurement points that the eye diagram measurements use for calculating the timing measurement results. For example, rise time is measured from the lower threshold to the upper threshold, while a RZ Pulse Width measurement is made between two middle thresholds.

Thresholds are not visible.

The three threshold choices are the standard measurement points:

- **10%-50%-90%**
- **20%-50%-80%**
- **User Defined**

The **Upper Threshold** and **Lower Threshold** variables are displayed when **User Defined** is selected. **Middle** threshold is fixed at the 50% level.

10%-50%-90% and 20%-50%-80%

These are two standard pulse measurement thresholds for all measurements. These standard thresholds are calculated as a percentage of the **One-Zero Level** value, while the **One Level** and **Zero Level** values are calculated from the eye diagram that is on the display.

10%-50%-90% means: Lower threshold = 10%, Middle threshold = 50% and Upper threshold = 90%. Use these thresholds for typical eye diagrams.

20%-50%-80% means: Lower threshold = 20%, Middle threshold = 50% and Upper threshold = 80%. Use these thresholds for eye diagrams with excessive ringing or overshoot.

Make sure that the eye diagram is expanded vertically and horizontally so that the instrument can accurately determine the **One Level** and **Zero Level** values of the eye. However, if too much of the **One Level** and **Zero Level** of the eye diagram is on the display, it may reduce the repeatability of your measurements. A good rule of thumb is to have two divisions of **One Level** and two divisions of **Zero Level**.

User Defined

You can use the **User Defined** setting to define thresholds for eye diagrams at the positions you want.

7.4.2.1.3 Upper Threshold and Lower Threshold

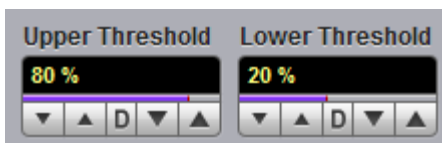

The **Upper Threshold** and **Lower Threshold** variables are displayed only when the **User Defined** option of the [Thresholds](#) menu is selected.

Upper Threshold can be set from 55% to 95%, while the **Lower Threshold** can be set from 5% to 45%.

7.4.2.2 Statistics

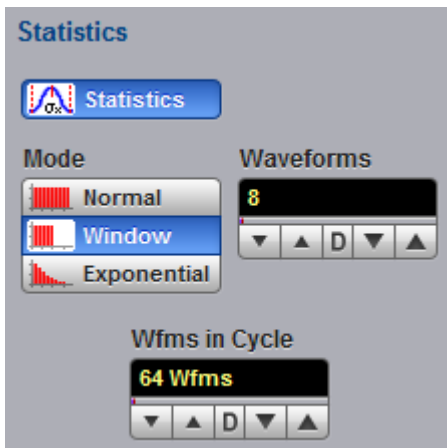

Click the **Statistics** menu to open an eye diagram calculation statistics menu.

7.4.2.2.1 Statistics



On Turns on statistical calculation for the eye diagram.

Off Turns off statistical calculation for the eye diagram.

7.4.2.2.2 Mode

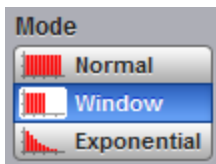

The **Mode** menu defines one of three modes for statistical calculations.

Normal Each of the acquired waveforms has equal influence on the eye diagram statistics. The [Waveforms & Weight](#) variables are not active in this mode.

Window Only the last specified number of acquired waveforms will have equal influence on the eye diagram statistics. The [Waveforms](#) variable specifies the number of these influenced waveforms.

Exponential Each of the acquired waveforms has a weighted influence on the result of the eye diagram statistics. The [Weight](#) variable specifies the degree of this influence.

7.4.2.2.3 Waveforms & Weight



The **Waveforms** variable specifies the number of influenced waveforms when the **Window** is selected in the [Mode](#) menu. The **Waveforms** can be varied from 8 to 8192 in multiples of two.

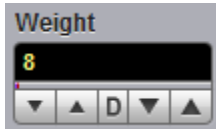

The **Weight** variable specifies the degree of influence of the latest acquired waveform against more remote waveforms. The **Weight** variable is active when **Exponential** is selected in the [Mode](#) menu. The **Weight** can be varied from 8 to 8192 in multiples of two.

7.4.2.2.4 Waveforms In Cycle



The **Wfms in Cycle** variable determines how many acquired waveforms will be used for the one-measurement cycle in eye diagram calculations.

The variable can be adjusted from 64 to 1024 waveforms per one-measurement cycle.

7.5 Histogram Menu



A **Histogram** is a probability distribution diagram that shows the distribution of acquired data from a source within a user-definable window. The information gathered by the histogram is used to perform statistical analysis on the source. You can display the histogram either vertically for voltage measurements or horizontally for timing measurements.

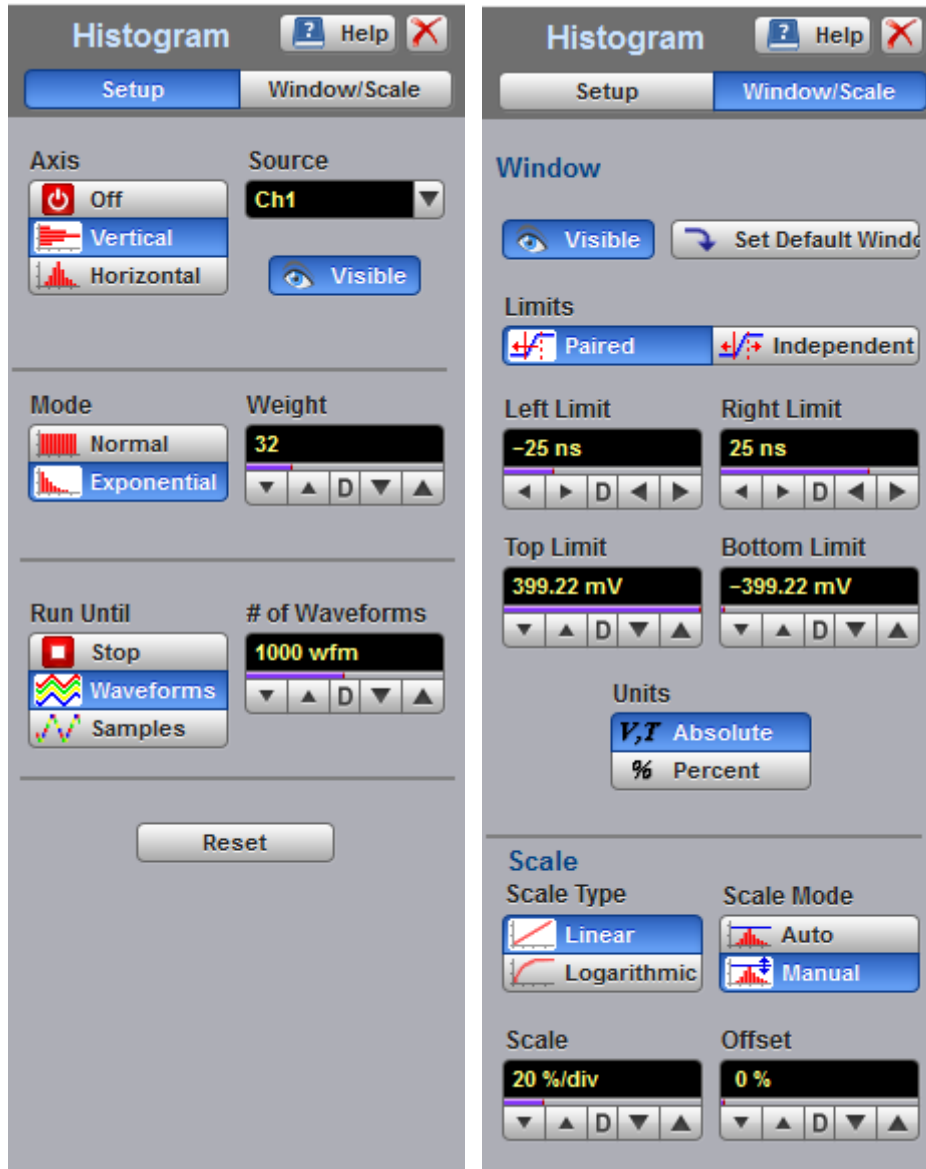

The Histogram menu

Histograms are derived from the instrument measurement database. The measurement database consists of all data samples displayed on the display graticule. Every time a display sample point is acquired at a display coordinate, the counter for that coordinate is incremented. As the total count increases, the range of hits also increases. The maximum count for each counter is 63 488. If the histogram is left on for a very long time, the database will become saturated.

The most common uses for histograms are measuring and characterizing noise or jitter on displayed waveforms. Noise is measured by sizing the histogram window to a narrow portion of time and observing a vertical histogram that measures the noise on an edge. Jitter is measured by sizing the histogram window to a narrow portion of voltage and observing a horizontal histogram that measures the jitter on an edge.

When the histogram is turned on, the instrument begins to build its measurement database. Then the following events occur:

- The histogram is displayed as a series of lines on the display graticule.
- The histogram data is analyzed.
- The results of the histogram are displayed on the [Measurement Area](#) of the display.

The histogram is displayed as a series of horizontal or vertical lines (depending on the axis selected in the [Axis](#) menu). Each line is the width of one pixel on the display graticule. Each line is carefully positioned on the display graticule within the histogram window and appears above the waveforms. Therefore, the source waveform may not be viewed through the histogram waveform.

The measurement database continues to build until the instrument stops acquiring data for the histogram.



The measurement database is active in the persistence or color-graded display styles.



To avoid erroneous data, reset the measurement database by pressing the [Clear](#) button. Changing the vertical scale, offset, timebase scale, delay, and trigger settings will not reset the measurement database.

Histogram measurement results

You will see the histogram statistics listed in the [Measurement Area](#) of the GUI. These values are displayed on tabs.

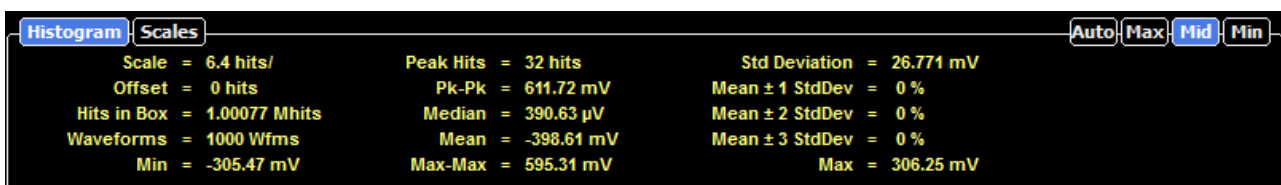

The tabs only appear as one of the histogram measurements is performed. For example, if you perform a vertical histogram measurement on channel 1, only this tab will appear on the display.

The measurement database and the graticule display will clear when you perform the following actions:

- Switch between operating modes in the **Display** menu.
- Change vertical and horizontal scale and position.
- Click on the **Clear Display** button.

The **Measure tab** displays the following measurement statistics for each measurement:

- **Scale** Lists the display scale in hits per division or dB per division.
- **Offset** Lists the offset in hits or dB. Offset is the number of hits or dB at the bottom of the display, as opposed to the center of the display.
- **Hits in Box** The total number of samples included in the histogram box.

- **Waveforms** The number of waveforms that have contributed to the histogram.
- **Peak Hits** The number of hits in the histogram's greatest peak.
- **Pk-Pk** The width of histogram. For horizontal histograms, width is the time difference between the first and last pixel columns that contains data. For vertical histograms, width is the difference in time between the first and last pixel rows that contain data.
- **Median** 50% of the histogram samples are above the median and 50% are below the median.
- **Mean** Mean is the average value of all the points in the histogram.
- **StdDev** The standard deviation (σ) value of the histogram.
- **Mean \pm 1 StdDev** The percentage of points that are within $\pm 1\sigma$ of the mean value.
- **Mean \pm 2 StdDev** The percentage of points that are within $\pm 2\sigma$ of the mean value.
- **Mean \pm 3 StdDev** The percentage of points that are within $\pm 3\sigma$ of the mean value.
- **Min** Min is the minimum value of all the points in the histogram.
- **Max** Max is the maximum value of all the points in the histogram.
- **Max-Max** The width between the vertical histogram's greatest peak.



The measurement statistics reported will vary depending on the mode of operation selected.

Mean and Standard Deviation

The PicoScope 9400 Series oscilloscope calculates the mean and standard deviation automatically. It does not rely on the assumption that the data is of a particular distribution to determine the sample mean or standard deviation. The microprocessor-controlled acquisition allows the oscilloscope to store and display every data point. Therefore, the sample mean and standard deviation are easily computed by the microprocessor using the following equations respectively:

$$\bar{X} = \frac{\sum_{i=1}^n X_i}{n}$$

$$\sigma = \sqrt{\frac{\sum_{i=1}^n (X_i - \bar{X})^2}{n-1}}$$

where: \bar{X} - mean, σ - standard deviation, n - number of samples, and X_i - value of each sample.

The mean for time histogram is the time from the trigger point (without taking into account minimum delay) to the sample average. The mean for voltage histograms is the average voltage with respect to the ground reference.

7.5.1 Setup

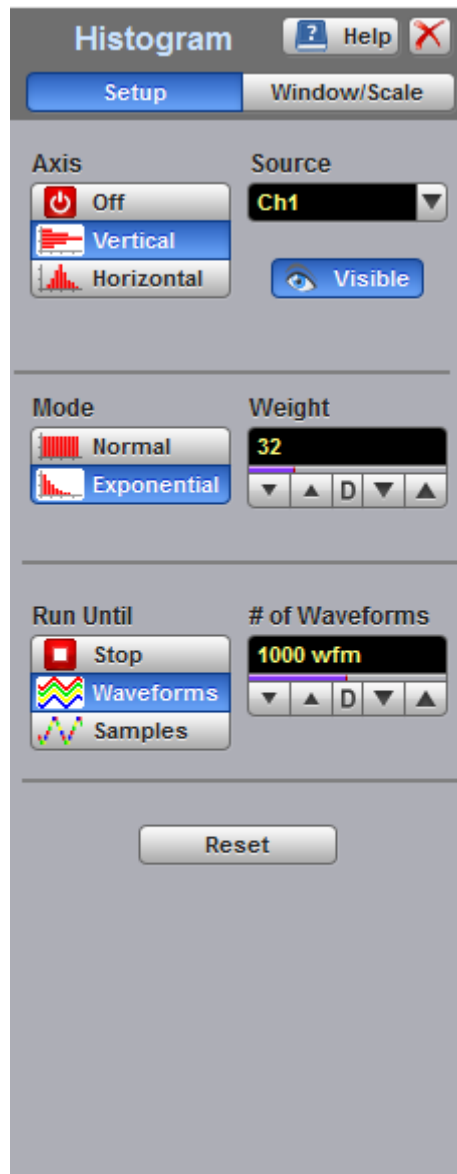
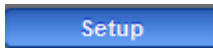

The Histogram Setup menu

7.5.1.1 Axis

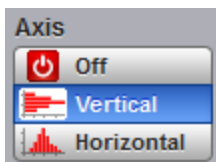

The **Axis** function turns the display of the histogram off or orients the histogram vertically or horizontally.

- **Off** Removes the histogram and histogram value from display.
- **Vertical** Places the histogram at the left side of the graticule, which allows for voltage measurements.

- **Horizontal** Places the histogram at the bottom of the graticule area, which allows for timing measurements.

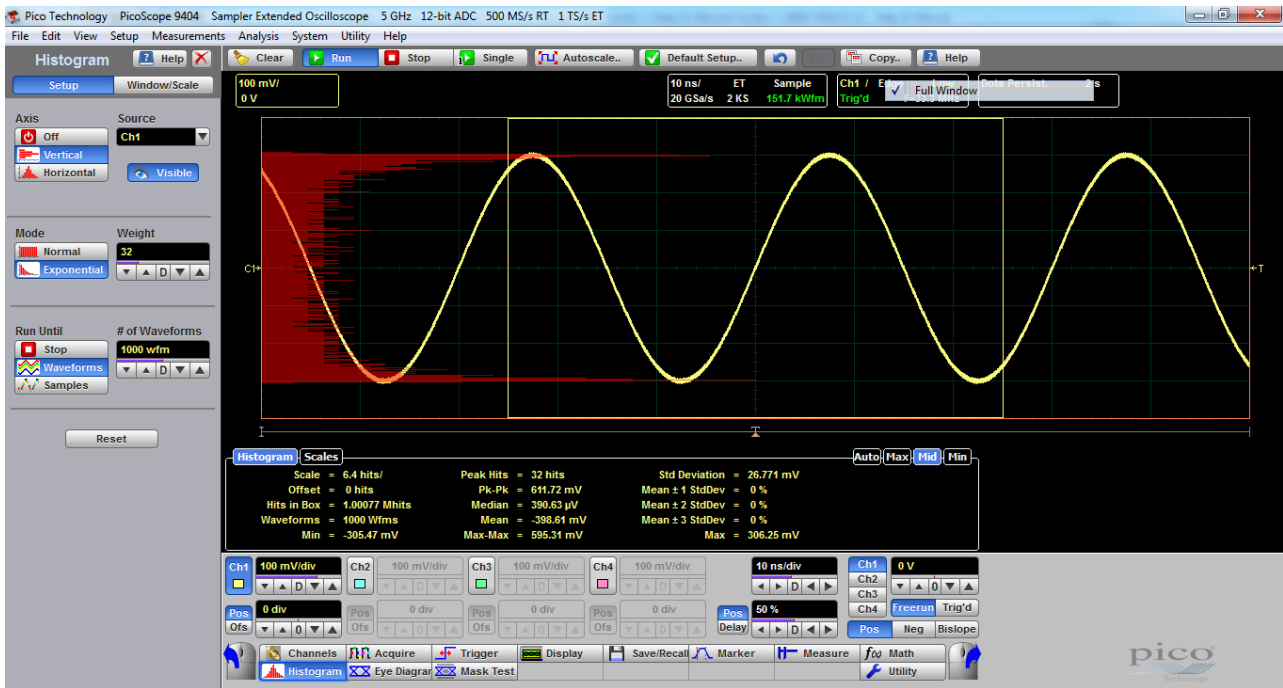

An example of the vertical histogram display

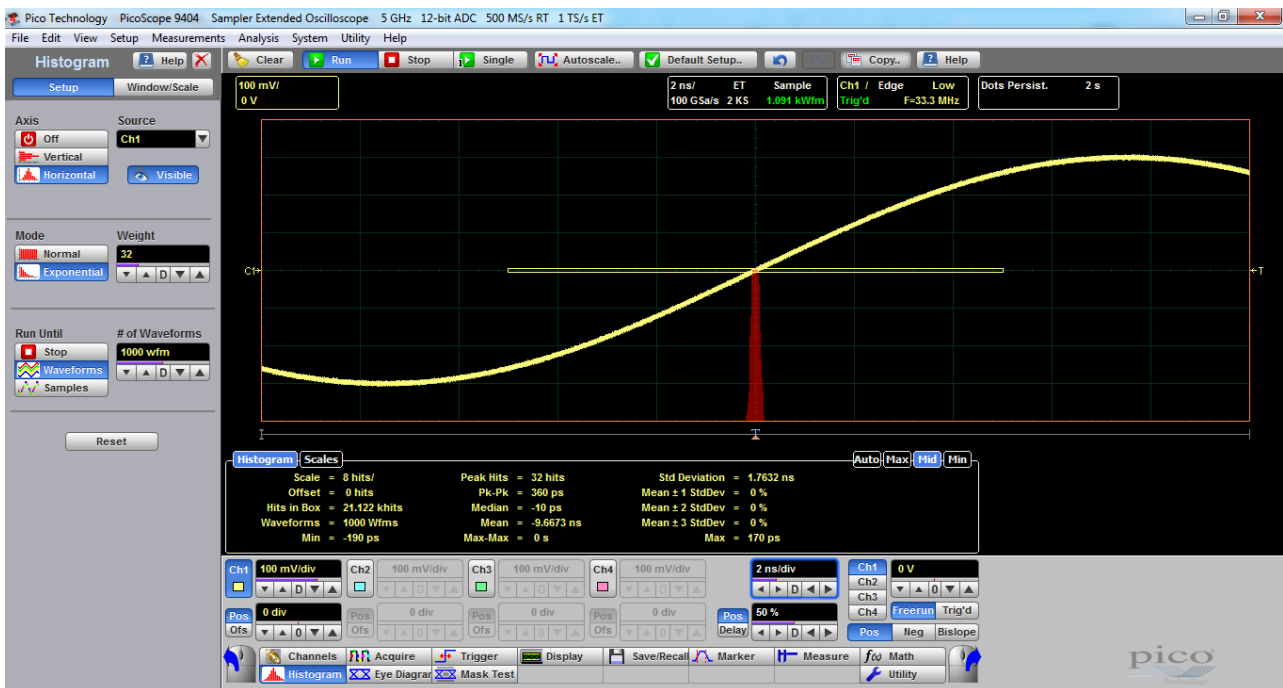

An example of the horizontal histogram display

7.5.1.2 Source

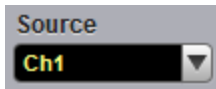

Histogram measurements can be made on only one source at a time. Select the source you want to measure using the **Source** menu. Be aware that even if the display shows only the most recent acquisitions, the measurement database keeps track of all display coordinates hit while the measurement database is building.

You can set the histogram source:

- Channel
- Function
- Waveform memory
- Spectrum

7.5.1.3 Visible



The **Visible** turns on or off the display of a histogram and histogram window. Turning off a histogram does not turn off the measurement process.

7.5.1.4 Mode

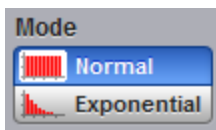

The **Mode** menu defines one of two modes that determine an algorithm for statistical calculation.

- **Normal** - When the **Normal** mode is selected, each of the acquired waveforms has equal influence on the result of the statistical calculations on the histogram. The **Weight** variable is not active in this mode.
- **Exponential** - When the **Exponential** mode is selected, each of the acquired waveforms has a weighted influence on the result of statistical calculations on the eye diagram. The **Weight** variable specifies the degree of this influence.

7.5.1.5 Weight

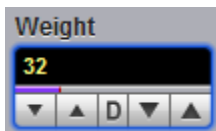

The **Weight** variable specifies the degree of influence of the nearest acquired waveform against more remote waveforms. The **Weight** variable is active when **Exponential** is selected in the **Mode** menu. The **Weight** can be varied from 8 to 8192 in multiples of two.

7.5.1.6 Run Until

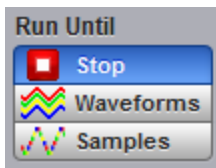

The **Run Until** menu allows you to determine when the acquisition of data stops.

- **Stop** You must press the **Stop** key to stop the acquisition of data.
- **Waveforms** After the number of waveforms is reached, acquisition stops.
- **Samples** After the number of samples is reached, acquisition stops.

7.5.1.7 # of Waveforms and # of Samples



- **# of Waveforms.** Sets the number of waveforms. After the selected number of waveforms is reached, acquisition stops.
- **# of Samples.** Sets the number of samples. After the selected number of samples is reached, acquisition stops.

7.5.2 Window

Window/Scale

Common uses for histograms are measuring and characterizing noise or jitter on displayed waveforms.

Noise is measured by sizing the histogram window to a narrow portion of time and observing a vertical histogram that measures the noise on a flat section of a waveform.

Jitter is measured by sizing the histogram window to a narrow portion of voltage and observing a horizontal histogram that measures the jitter on an edge.

The histogram window determines which region of the database will be used to construct the histogram. The instrument will use only this region of the database to calculate the histogram results.

To define the histogram window, choose **Window/Scale** from the **Histogram** menu. The histogram **Window** menu allows you to select a region of the database to include in the histogram. The **Window** menu opens the histogram window markers. The markers consist of:

- Two solid vertical lines (the [Left Limit and Right Limit](#) variables).
- Two solid horizontal lines (the [Top Limit and Bottom Limit](#) variables)

You can then define the size of the histogram window within the horizontal and vertical scale limits of the instrument.

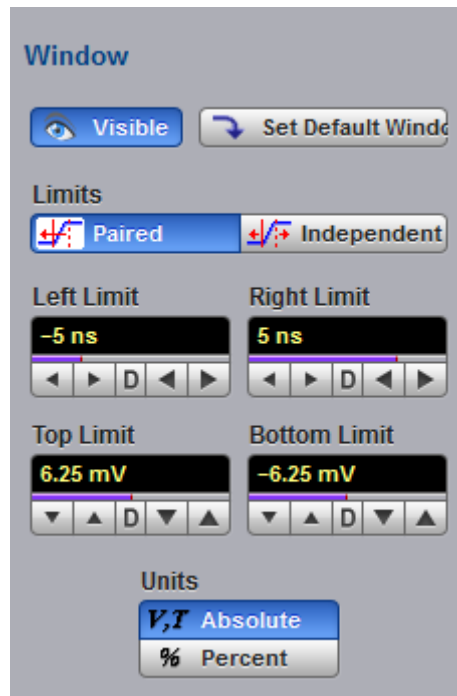

The Histogram Window menu

7.5.2.1 Visible



Visible is used to show histogram windows with both vertical and horizontal histogram limits.

Clicking **Visible** turns the display of the selection on or off.

7.5.2.2 Set Default Window

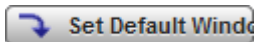

Sets the default histogram window for both vertical or horizontal histograms.

7.5.2.3 Limits



The **Limits** menu defines how the histogram window can be positioned with the **Left Limit**, **Right Limit**, **Top Limit** and **Bottom Limit** variables.

Paired

With the **Paired** method, the following conditions are used for positioning of the histogram window:

- The **Left Limit** variable changes the full histogram window to left or to right.
- The **Right Limit** variable changes the right limit of the histogram window to left or to right.
- The **Top Limit** variable changes the full histogram window up or down.
- The **Bottom Limit** variable changes the bottom limit of the histogram window up or down.

Independent

When the **Independent** is selected, each of the **Left Limit**, **Right Limit**, **Top Limit** and **Bottom Limit** variables changes the position of the corresponding limit independently.

7.5.2.4 Left Limit, Right Limit, Top Limit and Bottom Limit

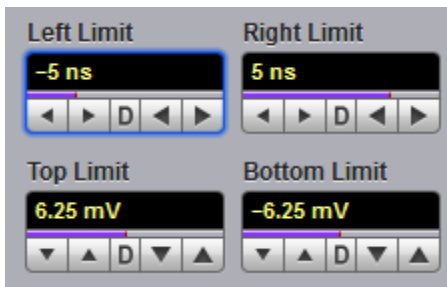

The **Left Limit**, **Right Limit**, **Top Limit** and **Bottom Limit variables** allow you to use the histogram limits to select a region of the database.

When the [Independent](#) mode in the **Limits** menu is selected, the **Top Limit** and **Bottom Limit** variables move the vertical histogram limits vertically across the display, while the **Left Limit** and **Right Limit** variables move the horizontal histogram limits horizontally across the display.

When the [Paired](#) mode in the **Limits** menu is selected, the **Top Limit** variable moves the full histogram window up or down, and the **Left Limit** variable moves the full histogram window left or to right. At the same time the **Bottom Limit** variable moves the bottom limit of the histogram window up or down, while the **Right Limit** variable moves the right limit of the histogram window left or to right.

Because the database that the histogram is derived from is limited to the size of the graticule area, placing the histogram limits beyond the graticule area results in a histogram of only the graticule area.

For jitter measurements you would position the **Top Limit** and **Bottom Limit** histogram limits so that the histogram is built from a very narrow horizontal slice of the graticule area. For noise measurements, you would position the **Left Limit** and **Right Limit** histogram limits so that the histogram is built from a very narrow vertical slice of the graticule area.



The histogram window limits are only visible when the [Histogram](#) menu is opened.

The default setup positions of the histogram markers as follows:

- **Left Limit < Right Limit.**
- **Bottom Limit < Top Limit.**

The values of **Left Limit** and **Bottom Limit** cannot be made greater than the values of **Right Limit** and **Top Limit** by repositioning the limits. The histogram window is always the area inside the boundaries of all of **Left Limit**, **Right Limit**, **Top Limit** and **Bottom Limit**, regardless of the limit values.

You can use the mouse to click and drag the histogram limits to new positions: click and hold the left mouse button while the mouse pointer is on one of the limits, then drag the marker to the position you want and release the mouse button. Clicking and dragging a limit makes it easy to quickly move the limit to the desired waveform event.



The values of the limits and the position arrows are dependent upon the vertical and horizontal scale settings.

7.5.2.5 Units

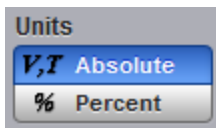

The **Units** function lets you select how you want the [Left Limit](#), [Right Limit](#), [Top Limit](#) and [Bottom Limit](#) variables represented.

- **Absolute** Represents all limits in current unit.
- **Percent** Represents all limits as percentages of the full vertical or horizontal scale.

7.5.3 Scale

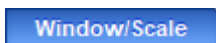

Histograms are derived from the instrument measurement database. The histogram values correspond to a row or column in the database. The database that is used to construct the histogram is dependent upon the selected source. The instrument converts the row and column numbers to time (seconds) and amplitude (volts) values using the scaling values of the selected the database source. Therefore, the histogram results from each source vary depending on the scaling of the source.

Histograms are displayed as a series of lines (vertical or horizontal). The length of each line represents the frequency or number of hits of data on that row (or column) of the display. Zero hits correspond to the left edge of the graticule (vertical histogram), or the bottom edge of the graticule (horizontal histograms).

The histogram **Scale** menu gives you access to a second-level menu that allows you to set the scale of the histogram.

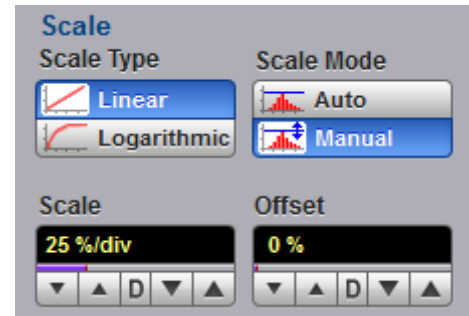

The Histogram Scale menu

7.5.3.1 Scale Type

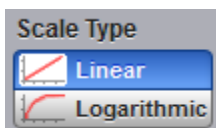

The **Scale Type** menu defines how to display histogram data. Two options can be set from the **Scale Type** menu: **Linear** and **Logarithmic**.

- **Linear** - Sets the display of the histogram results to the number of hits per division.
- **Logarithmic** - Sets the display of the histogram results to dB.

7.5.3.2 Scale Mode

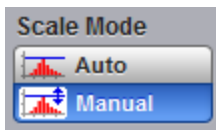

The **Scale Mode** menu determines how much of the histogram is displayed on the screen.

Auto

If the **Axis** menu is set to [Horizontal](#), the **Auto** sets the base of the histogram to the bottom of the graticule area and displays the histogram using half of the graticule height.

If the **Axis** menu is set to [Vertical](#), the **Auto** sets the base of the histogram to the left edge of the graticule area and displays the histogram using half of the graticule width.

Manual

Manual lets you window in on the histogram by allowing you to change the scale and offset settings. Depending on the setting of the [Scale Type](#) menu, the scale value is in either percent of a division or dB. By changing the scale, you can zoom in or out on the histogram. Offset allows you to pan across the histogram by moving the base of the histogram. Depending on the setting of the [Scale Type](#) menu, the offset value is also in either percent of peak or dB per division.

7.5.3.3 Scale

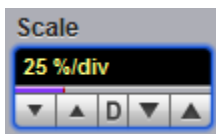

Linear scale

For the linear scale type, the scale is the percentage of the peak per division. For example, on a horizontal histogram, 20% places one-fifth of the histogram in each of eight divisions with the top of the peak (100%) at the middle of the display.

Logarithmic scale

For the log scale type, the scale is in decibels per division. The histogram is plotted according to the following formula:

$$dB = 20 \log_{10} \frac{X}{Peak}$$

where: X is the number of hits in a histogram row for vertical histograms, or the number of hits in a histogram column for horizontal histograms. $Peak$ is the number of hits in the largest histogram column or row, and dB is the log value that gets plotted.

7.5.3.4 Offset

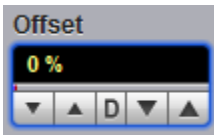

Linear offset

For the linear scale type, the offset is the percentage of the peak at the left edge or lower edge of the display. For example, on a horizontal histogram, an offset of 20% places 20% of the peak at the lower edge of the display. Therefore, 20% of the histogram will be below the display and the other 80% of the histogram will be above the lower edge of the display (displayed on the screen).

Logarithmic offset

For the log scale type, the offset is in decibels at the left edge or lower edge of the display. The histogram is plotted according to the following formula:

$$dB = 20 \log_{10} \frac{X}{Peak}$$

where: X is the number of hits per row for vertical histograms, or the number of hits per column for horizontal histograms. $Peak$ is the number of hits in the peak, and dB is the log value that gets plotted.

This means 0 dB is at the peak of the histogram and the offset can only contain negative values. For

example, with a horizontal histogram, an offset of -20 dB places 10% or $10^{\frac{-20}{20}}$ of the peak at the lower edge of the display.

7.6 Marker Menu

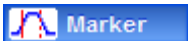

Markers are movable lines on the display. You set their value by positioning them on the display. Their actual value, however, comes from internal data, so they are more precise than graticules. They use numeric readouts to present results.

You can drag markers to measure waveforms on screen.

Markers can be positioned on either:

- A selected waveform source (input channel, waveform memory, function or spectrum).
- Independently anywhere on the display graticule.

Markers allow you to make:

- Absolute vertical measurements (voltage, spectrum magnitude, spectrum phase).
- Ratiometric vertical measurements.
- Absolute horizontal measurements (timing, bit period, frequency).
- Ratiometric horizontal measurements.

The markers are display-limited, so you cannot move them off screen. Also, if you resize waveforms, the markers do not track. That is, a marker stays at its screen position, ignoring changes to horizontal and vertical scale and position.

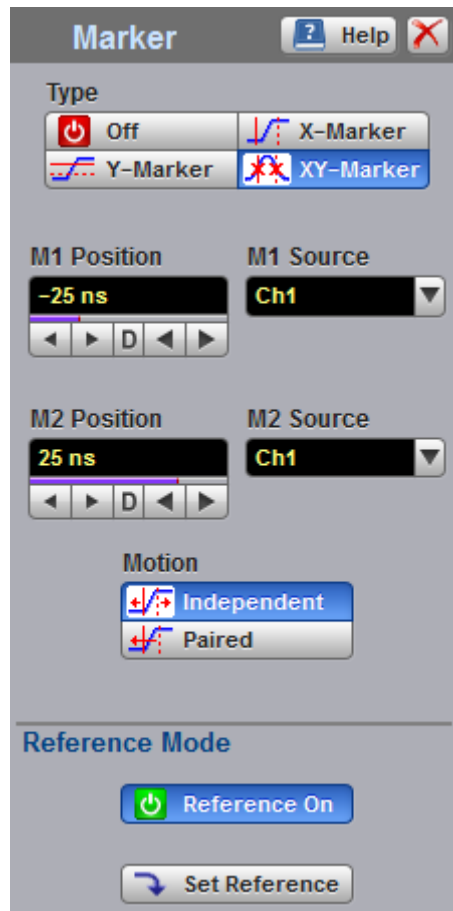

The Marker menu

The **Marker** menu allows you to turn on and position calibrated colored markers on the display. For example, you can use the **M1 Position** (solid line) control to move the **X1** marker horizontal position. The position value of the marker will be displayed in the [Measurement Area](#) of the display.

Markers can be changed to a different color in the display menu. You can use the markers to make custom measurements or to use as visual reference points on the display.

To display the **Marker** menu, click the  **Marker** button in the main menu.

Marker measurement results

The [Measurement Area](#) of the **GUI** displays the values of the marker positions and measurements on tabs. The marker position readout is based on the units of the source waveform. The marker resolution is limited to the resolution of the display. As you move a marker, its position is displayed in the **Measurement Area**. The horizontal value (X-axis) is the time delay from the left border of the display graticule and the vertical position (Y-axis) is measured with respect to the corresponding source ground.

Marker	Scales		
XM1 = 4.39 ns	XM2 = 8.605 ns	dXM = 4.215 ns	1 / dXM = 237.248 MHz
YM1 = 92.68 mV	YM2 = -188.4 mV	dYM = -281.08 mV	dYM / dXM = -66.686 V / μ s
dXM = 8.36 %	dXM = 30.1 °	dYM = 425 %	dYM = 12.6 dB

The following information is displayed for the selected source or waveform:

- **XM1**: Position of the **M1** marker (solid line). The X-axis units may be displayed in seconds, Hz or bits.
- **YM1**: Position of the **M1** marker (solid line). The Y-axis units depend upon the channel input, and may be displayed in volts, watts, amperes, phase degrees.
- **XM2**: Position of the **M2** marker (dashed line). The X-axis units may be displayed in seconds, Hz, bits.
- **YM2**: Position of the **M2** marker (dashed line). The Y-axis units depend upon the channel input; and may be displayed in volts, watts, amperes, phase degrees.
- **dXM**: The difference between the **M1** and **M2** marker values, if both markers are turned on. **dXM** is calculated as follows:

$$dXM = XM2 - XM1$$

where **XM2** represents the dashed line marker, and **XM1** represents the solid line marker.

If **XM1** is more positive than **XM2**, **dXM** will be a negative number, which can result in negative time interval measurements.

- **1/dXM**: The instrument will also calculate and display the **1/dXM** frequency value when both X-axis markers are turned on. If **XM1** is more positive than **XM2**, **1/dXM** will display a negative frequency.
- **dYM**: The difference between the **YM1** and **YM2** marker values, if both markers are turned on. **dYM** is calculated as follows:

$$dYM = YM2 - YM1$$

where **YM2** represents the dashed line marker, and **YM1** represents the solid line marker.

If **YM1** is more positive than **YM2**, **dYM** will be a negative number.

7.6.1 Type

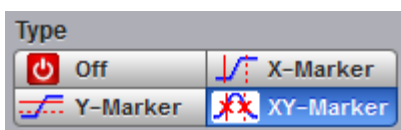

There are three types of markers:

- **X-Markers** (manual markers).
- **Y-Markers** (manual markers).
- Waveform markers.

Click the button for the marker type that you need.

Off

Removes the markers and marker value from display.

X-Marker

The **X** manual markers (**XM1** and **XM2** markers) are two vertical lines you can move horizontally. The **XM1** is displayed as a solid line, and the **XM2** is displayed as a dashed line.

You can position the **X-Markers** anywhere on the display, which allows you to make custom measurements. The **X-Markers** track the time values as the time base scale is changed, which allows you to make accurate delay measurements. The position readout is based on the scale factors of the source waveform. Marker resolution is limited to the pixel resolution of the display.

Y-Marker

The **Y** manual markers (**YM1** and **YM2** markers) are two horizontal lines you can move vertically. The **YM1** is displayed as a solid line, and the **YM2** is displayed as a dashed line.

You can position the **Y-Markers** anywhere on the display, which allows you to make custom measurements. The **Y-Markers** track the voltage values as the vertical scale is changed, which allows you to make accurate voltage measurements. The position readout is based on the scale factors of the source waveform. Marker resolution is limited to the pixel resolution of the display.

Waveform Markers

The **XYM1** and **XYM2** are two waveform markers displayed as **X** symbols. Each marker is in effect both a horizontal and vertical marker. Neither of these markers can be moved off the waveform. The **XY-markers** track the waveform data in memory rather than on the displayed waveform. Because the waveform data in memory has a much greater resolution than the display, the measurements you make with the **XY-markers** are much more precise than measurements made with the manual markers. The **XY-markers** track the time as changes of the source signal. This allows you to make accurate delay measurements without having both markers on the display.

7.6.2 M1 Position and M2 Position



You can use different methods to control the positions of the markers:

- Use the **M1 Position** and **M2 Position** spin boxes.
- Use the mouse to click and drag markers to a new position.
- Use the keyboard.
- Use the [Pop-up Keypad](#) for quickly entering numeric data using the mouse.

Manual X Markers

The **M1 Position** variable moves the **XM1** marker horizontally, and the **M2 Position** variable moves the **XM2** marker horizontally. The position of each marker is displayed in the same color as the markers.

You can make timing measurements using **X markers** on the signal. The difference between the marker's positions is the timing measurement or **dXM**:

$$dXM = XM2 - XM1$$

If **XM1** is more positive than **XM2**, **dXM** will be a negative number, which can result in negative time interval measurements. Also notice the **1/dXM** value. If you are measuring the period of a signal with the **X-markers**, then **1/dXM** is the frequency of the signal. You can also make a channel-to-channel skew measurement by placing the **XM1** marker on one channel and the **XM2** marker on another channel.

Manual Y Markers

The **M1 Position** variable moves the **YM1** marker vertically, and the **M2 Position** variable moves the **YM2** marker vertically. The position of each marker is displayed in the same color as the markers.

You can make voltage measurements on the signal by placing the **Y** markers on the signal.

The difference between the markers is the voltage measurement or **dYM**:

$$dYM = YM2 - YM1$$

If **YM1** is more positive than **YM2**, **dYM** will be a negative number. You can also make a channel-to-channel voltage measurement by placing the **YM1** marker on one channel and the **YM2** marker on another channel.

Waveform XY Markers

The first **XY** marker is controlled by the **M1 Position** variable and the second **XY** marker is controlled by the **M2 Position** variable. The position of each marker is displayed in the same color as the markers.

Each **XY** marker has an **YM** position and **XM** position. Vertical measurements are made with the **YM** positions, and **dYM** is the difference between the **YM** positions (see $dYM = YM2 - YM1$). Timing measurements are made with the **XM** positions, and **dXM** is the difference between the **XM** positions (see $dXM = XM2 - XM1$). Notice **1/dXM**. If you are using the markers to measure the period of a signal, then **1/dXM** is the frequency of the signal. Also notice **dYM/dXM**. If you are measuring such parameters as the rise or fall of an impulse with the **XY** markers, then **dYM/dXM** is the slope of the signal.

7.6.3 M1 Source and M2 Source



You may set the source for each marker:

- Channels.
- Functions.
- Waveform memories.
- Spectra.

For example, you could set the **M1 Source** to a waveform on **channel 1**, and the **M2 Source** to a waveform in **memory M1**. The scale used to position each marker on the display is based on the scale of the waveform source to which the marker is tied.

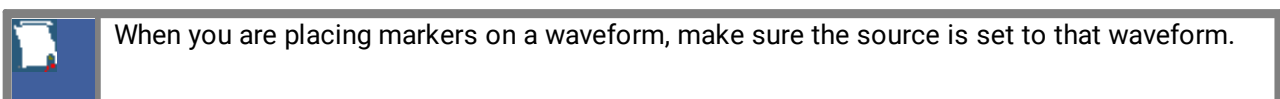
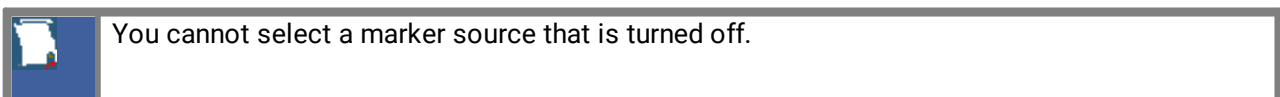

7.6.4 Motion

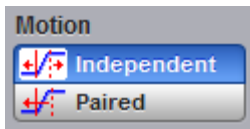

There are two options for the way in which PicoScope 9400 moves the markers:

Independent

When **Independent** motion is selected you can move each marker independently. The **M1 Position** variable moves the **XM1**, or the **YM1**, or the **XYM1** marker. The **M2 Position** variable moves the **XM2**, or the **YM2**, or the **XYM2** marker.

Paired

When **Paired** motion is selected you can move both markers with the **M1 Position** variable simultaneously, while the difference between markers can be moved with the **M2 Position** variable.

7.6.5 Reference On

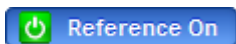

The **Marker** menu provides ratiometric measurements. These measurements give results in such ratiometric units as %, dB, and degrees.

Ratiometric measurements require a reference for comparison.

You can set the reference:

1. First adjust the markers to a predetermined positional difference representing an absolute reference or position the markers on a reference waveform to define a specific parameter such as peak-to-peak voltage or period.
2. When you click the [Set Reference](#) button, the ratiometric values for the reference in the Marker Measure tab become 100 %, 0 dB or 360°. These values are displayed in the same color as the markers.
3. When you change position of any marker, the results will be displayed in ratiometric values.

Click the **Reference On** button to select ratiometric measurements.

7.6.6 Set Reference

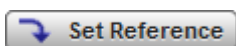

Clicking the **Set Reference** button sets the ratiometric values for the reference. As an example, they can be 100 %, 0 dB or 360°. These values are displayed in the same color as the markers. When you begin to change the position of any marker, the results will be displayed in ratiometric values.

7.7 Mask Test Menu

Mask Test

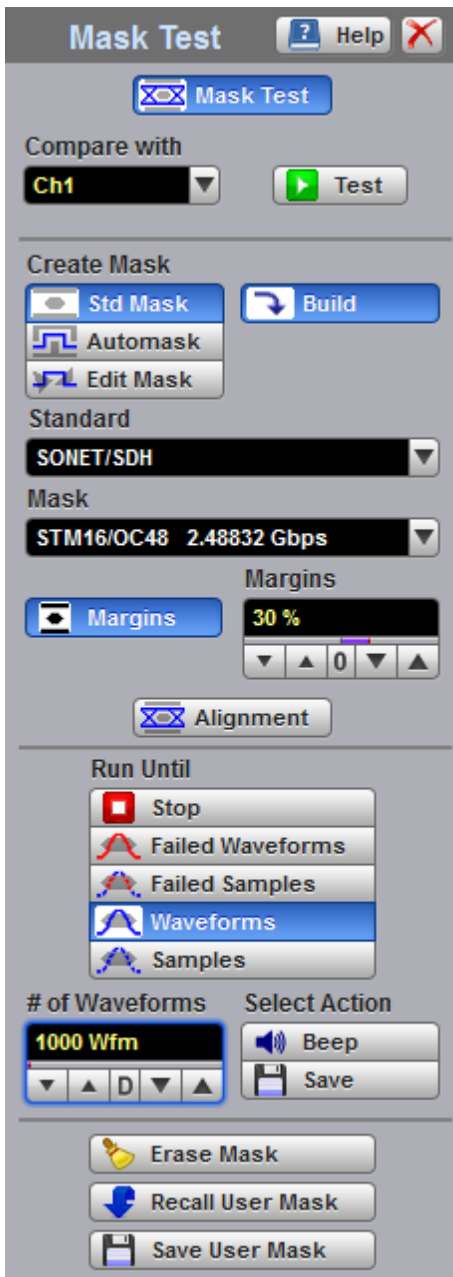

The Mask Test menu

There are industry standards that define the parameters for electrical and optical waveforms. Mask testing is a process you can use to verify that the displayed waveform complies with an industry-standard waveform shape or with the user-defined mask.

A mask is a template that consists of numbered, shaded regions on the instrument display screen. The input waveform must then remain outside these regions in order to comply with the industry standard. Any acquired data point that falls inside a mask margin appears in red.

The instrument has been designed to perform communication industry mask testing to a variety of test standards. Mask testing may be performed by a following simple procedure. This procedure loads one of several mask templates, automatically aligns the mask to the present waveform, and then determines the waveform's compliance to the mask. The size of the mask or the portion of the mask can be increased or decreased in a linear fashion to determine the waveform's margin of compliance. Both the user-defined and standard (factory-installed) masks can be stored to disk for rapid switching between instrument setups. Mask testing can also activate a variety of actions upon determining a test failure.

7.7.1 Compare with

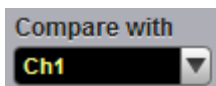

The **Compare with** menu determines which waveform the masks are compared against. You can select from any channel.

7.7.2 Test

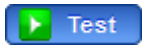

After selecting a mask, you can enable mask counting and see the results of the count. To enable mask counting, click the **Test** button.

If mask testing is on, you can read the results listed in the [Measurement Area](#) of the GUI. These values are displayed on tabs. Notice that any acquired data point that falls inside a mask or a mask margin appears in red.

The **Mask Test** tab displays the relevant test results.

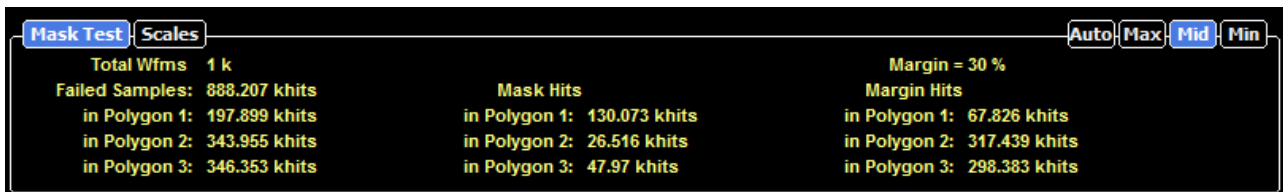

Measurement Area of Mask Test

7.7.3 Create Mask

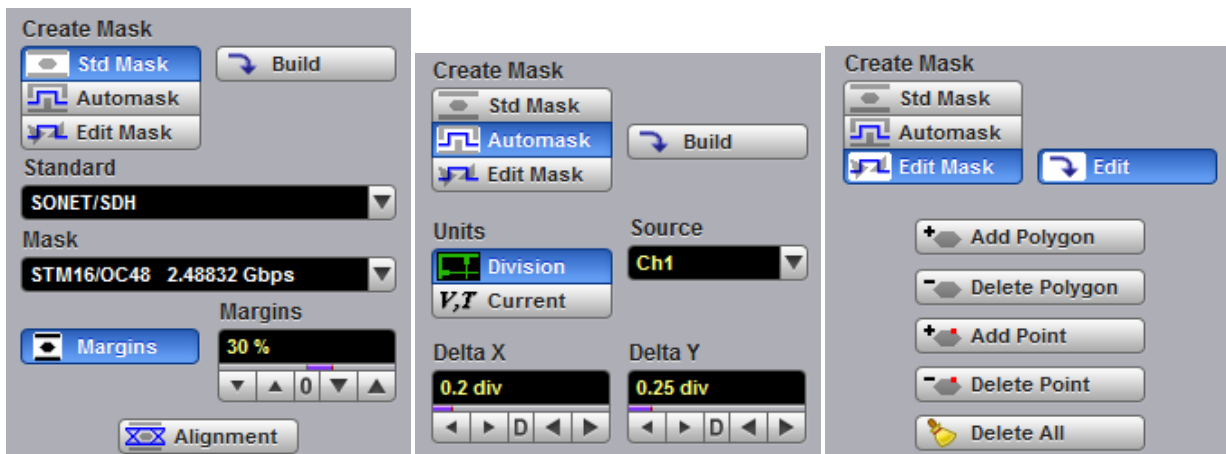

The Create Mask Menu

The **Create Mask** menu includes the following options:

- Select from industry-standard electrical and optical masks.
- Build an automask.
- Build a new user-defined mask.
- Edit any mask, and then save it to a memory.

7.7.3.1 Standard Mask

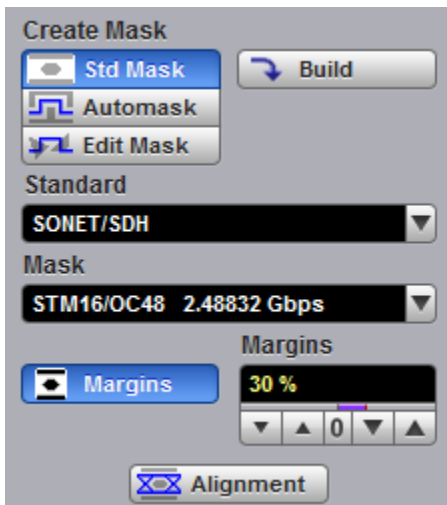

Clicking the **Std Mask** allows you to select from a variety of standard telecommunication masks.

Choose a standard to access a list of masks used for electrical or optical waveforms.

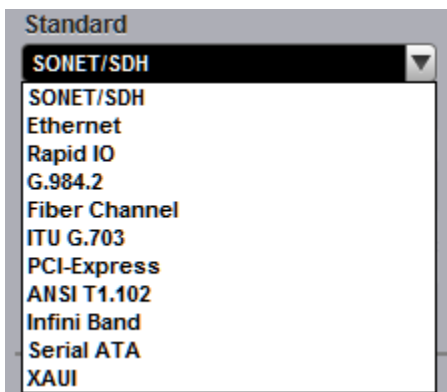

The PicoScope 9400 Series supports several standards for data-comms and telecomms masks. They are:

- SONET/SDH
- Ethernet
- RapidIO
- G.984.2
- Fibre Channel
- ITU G.703
- PCI Express
- ANSI T1.102
- InfiniBand
- Serial ATA
- XAUI

7.7.3.1.1 SONET/SDH Masks

Selecting the **SONET/SDH** standard opens the list of industry-standard masks.

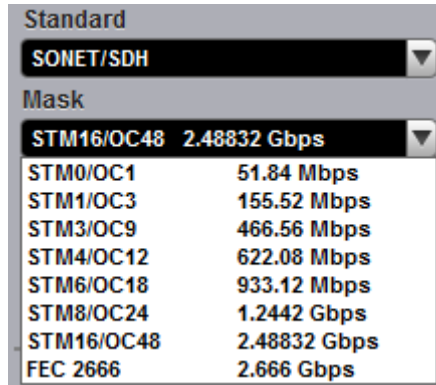

The list of industry-standard SONET/SDH masks

Any of these masks may be recalled from memory and used to test a waveform to a specific industry standard listed above. An example eye-diagram with the **STM16/OC48** industry-standard mask is shown below.

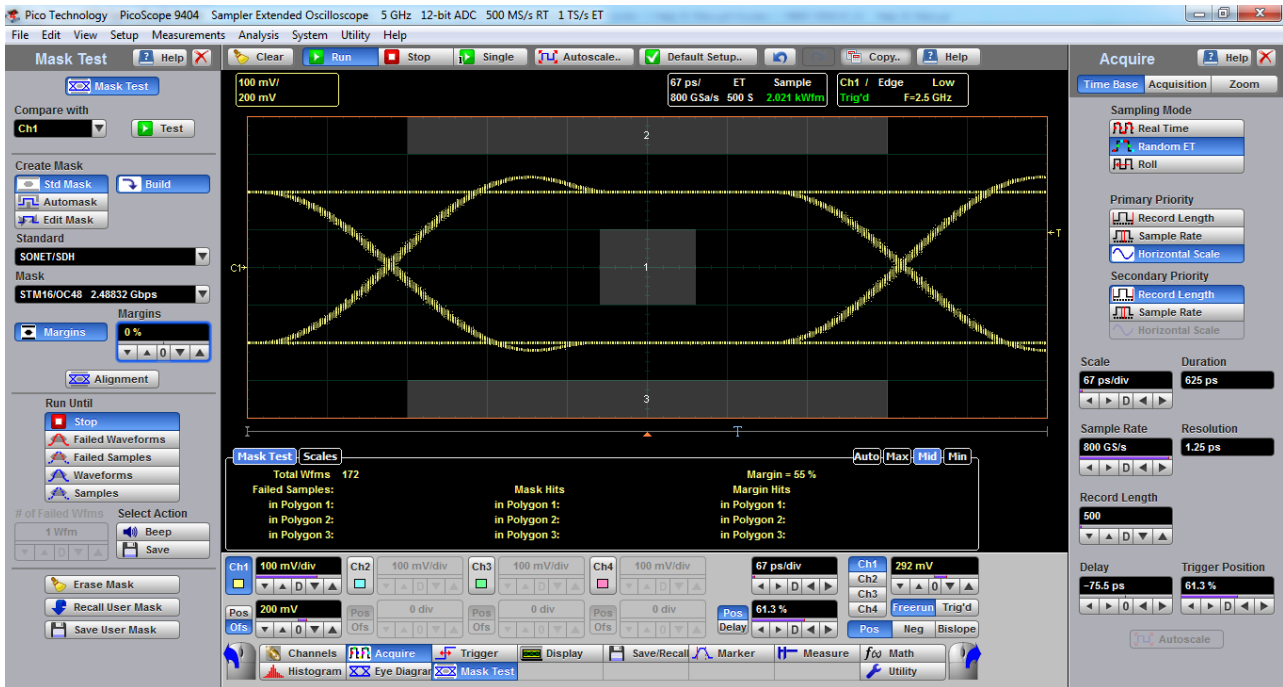

An example of eye-diagram with the STM16/OC48 SONET/SDH mask

7.7.3.1.2 Ethernet Masks

Selecting the **Ethernet** standard opens the list of industry-standard masks. Any of these masks may be recalled from memory and used to test a waveform to a specific industry standard listed above.

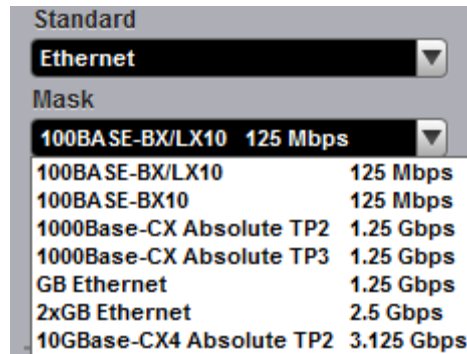

The list of industry-standard Ethernet masks

7.7.3.1.3 RapidIO Masks

Selecting the **RapidIO** standard opens the list of industry-standard masks. Any of these masks may be recalled from memory and used to test a waveform to a specific industry standard listed above.

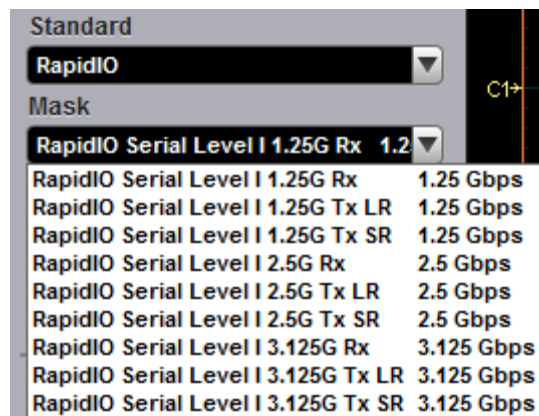

The list of industry-standard RapidIO masks

7.7.3.1.4 Fibre Channel Masks

Selecting the **Fibre Channel** standard opens the list of industry-standard masks. Any of these masks may be recalled from memory and used to test a waveform to a specific industry standard listed above.

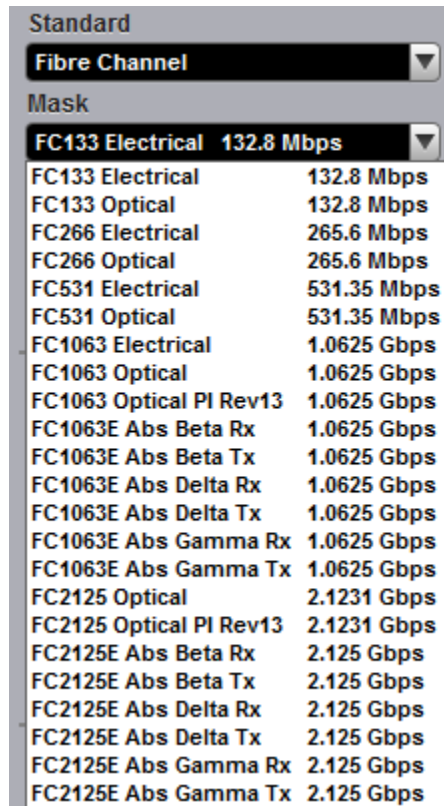

The list of industry-standard Fibre Channel masks

7.7.3.1.5 ITU G.703 Masks

Selecting the **ITU G.703** standard opens the list of industry-standard electrical masks. Any of these masks may be recalled from memory and used to test a waveform to a specific industry standard listed above.

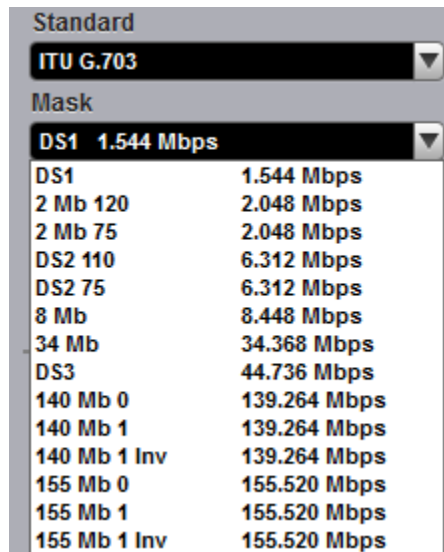

The list of industry-standard electrical ITU G.703 masks

7.7.3.1.6 PCI-Express Masks

Selecting the **PCI-Express** standard opens the list of industry-standard masks. Any of these masks may be recalled from memory and used to test a waveform to a specific industry standard listed above.

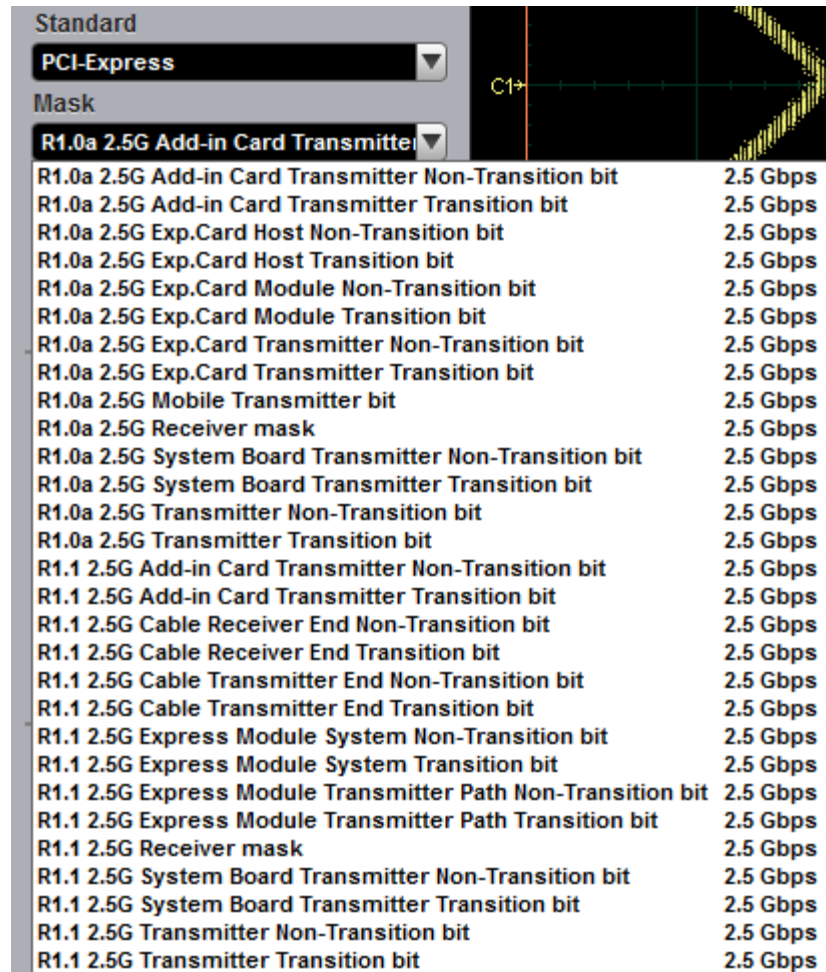

The list of industry-standard PCI-Express masks

7.7.3.1.7 ANSI T1.102 Masks

Selecting the **ANSI T1.102** standard opens the list of industry-standard electrical masks. Any of these masks may be recalled from memory and used to test a waveform to a specific industry standard listed above.

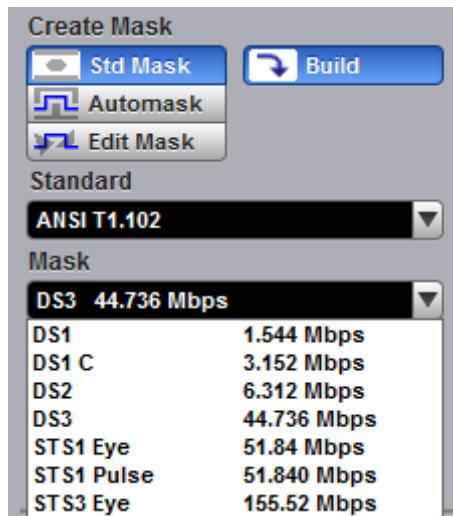

The list of industry-standard electrical ANSI T1.102 masks

7.7.3.1.8 InfiniBand Masks

Selecting the **InfiniBand** standard opens the list of industry-standard masks. Any of these masks may be recalled from memory and used to test a waveform to a specific industry standard listed above.

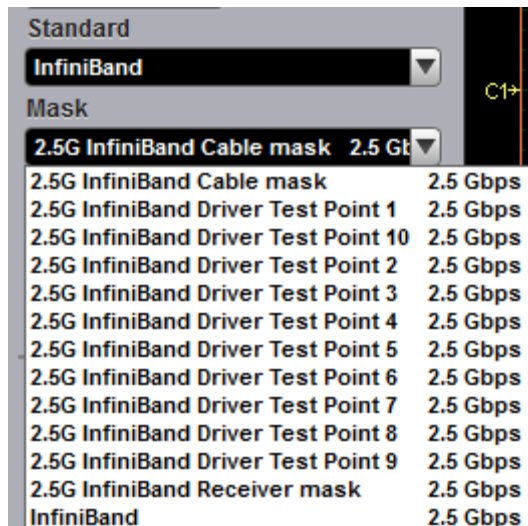

The list of industry-standard InfiniBand masks

7.7.3.1.9 Serial ATA Masks

Selecting the **Serial ATA** standard opens the list of industry-standard masks. Any of these masks may be recalled from memory and used to test a waveform to a specific industry standard listed above.

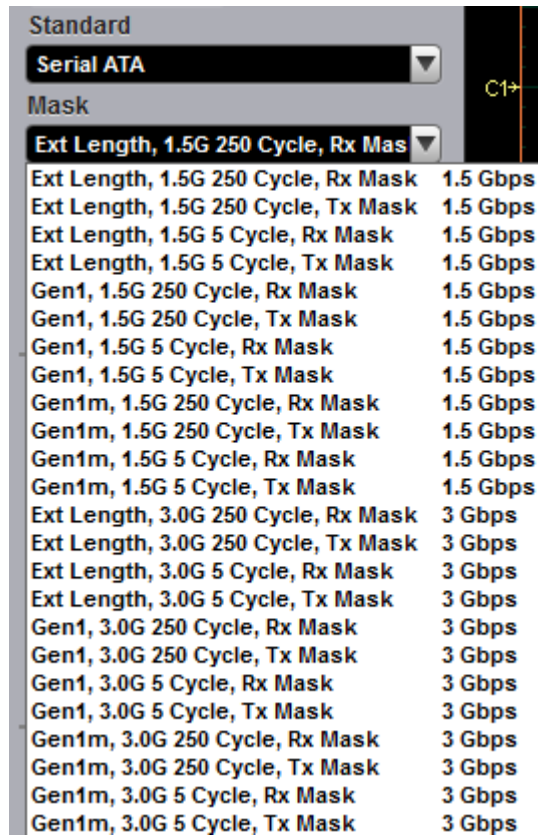

The list of industry-standard Serial ATA masks

7.7.3.1.10 XAUI Masks

Selecting the **XAUI** standard opens the list of industry-standard masks. Any of these masks may be recalled from memory and used to test a waveform to a specific industry standard listed above.

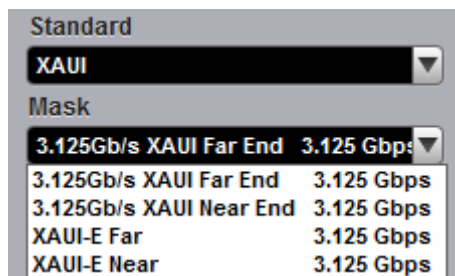

The list of industry-standard XAUI masks

7.7.3.1.11 Mask Margins

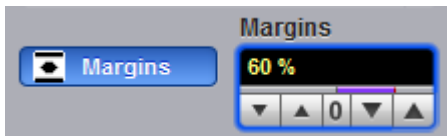

The **Margins** option is a part of each opened list of industry-standard masks. Mask margins are used to determine the margin of compliance for a standard mask. You can use both positive mask margins and negative mask margins. Positive mask margins determine how much larger you will be able to make the mask before violations will occur, while negative mask margins determine how much smaller you have to make the mask before violations no longer occur. You can then use this information to determine by what margin the waveform begins to fail to comply with industry standards.

To turn on the mask margins, check the **Margins** button on each opened list of industry-standard masks. After mask margins are enabled, use the **Margins** variable to adjust the percentage of margin you want, or use the [Pop-up Keypad](#) for quickly entering numeric data. You can enter a value between -100% and $+100\%$. For example, if you want to verify that the waveform can comply with a standard mask with a 20% margin, set the margin value to 20%. You can then increase the size of the margin by increasing the percentage until violations occur.

The instrument displays the mask margins in a different color than the mask. As with a mask, any acquired data point that falls inside a mask margin appears in red. Two examples of positive and negative margins are shown in the figures below. Notice that positive margins appear outside the mask regions, while negative margins appear inside the mask regions.

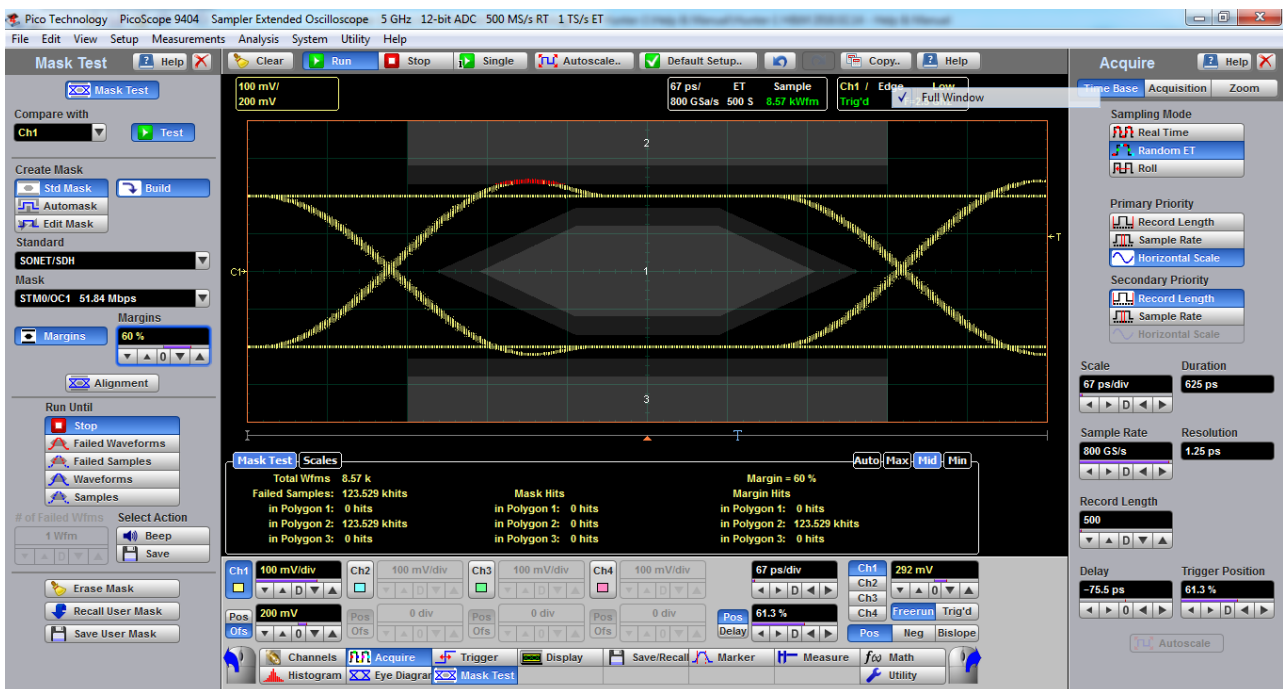

An example of eye-diagram with +60% mask margin

7.7.3.1.12 Alignment



The instrument can align the **Timebase Scale** to a selected industry-standard mask. To turn on the alignment option, click the **Alignment**.

7.7.3.1.13 Build or Edit



Clicking the **Build** button builds a [Standard mask](#) or [Automask](#).

Clicking **Edit** enters editing mode for a user-defined mask.

7.7.3.2 User-defined Masks

The **Mask Test** menu contains a mask-editing feature that allows you to create your own masks. These masks may be created using one of three methods:

- By using a reference waveform method ([Automask](#)). Masks are constructed by adding a [Delta X](#) and [Delta Y](#) tolerance around a reference waveform. This method is simple to use, though not as flexible as the polygon method.
- By using a polygon method for creating a unique new mask ([Edit Mask](#)). Using this method, polygons are created to mask off failure regions of the graticule. Up to eight polygons can be positioned in the graticule area, each with 3 to 512 sides. Very complex masks can be constructed by placing polygons within polygons. Similar to margin testing discussed above, this method allows testing of waveform failure rates to varying tolerances, because failures are listed individually for each polygon.
- By using a polygon method for modifying an existing mask ([Edit Mask](#)). This method involves the use of a reference waveform.

7.7.3.3 Automask

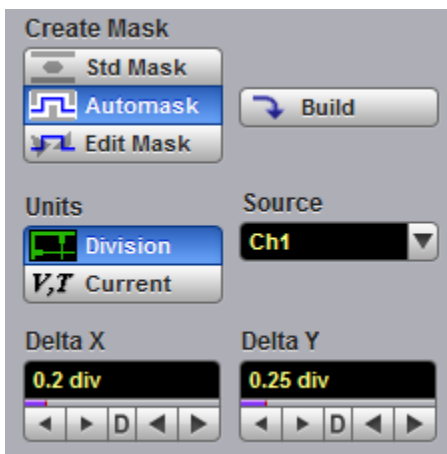

Clicking **Automask** opens a menu for using the reference waveform method. An example of the method for a noisy impulse is shown in the figure below.

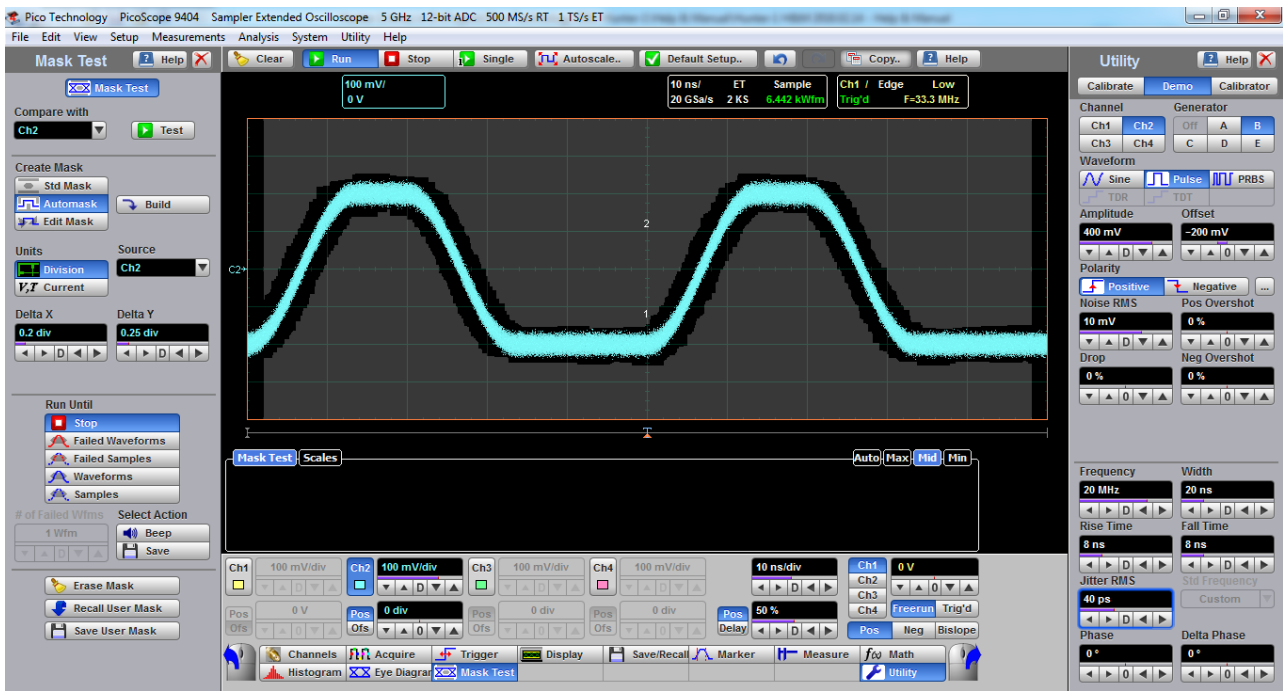

An example of Automask for a noisy pulse

7.7.3.3.1 Source

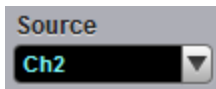

The **Source** function selects the channel, function, memory, or spectrum that the mask is scaled to.

7.7.3.3.2 Units

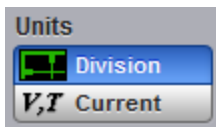

The **Units** function allows you to define [Delta X](#) and [Delta Y](#) in divisions or current source settings. Current is typically in volts and seconds or other appropriate units for the source.

7.7.3.3.3 Delta X

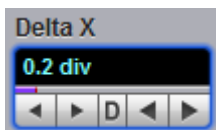

The **Delta X** variable defines the horizontal tolerance around the edges of the reference waveform.

7.7.3.3.4 Delta Y



The **Delta Y** variable defines the vertical tolerance around the edges of the reference waveform.

7.7.3.4 Edit Mask

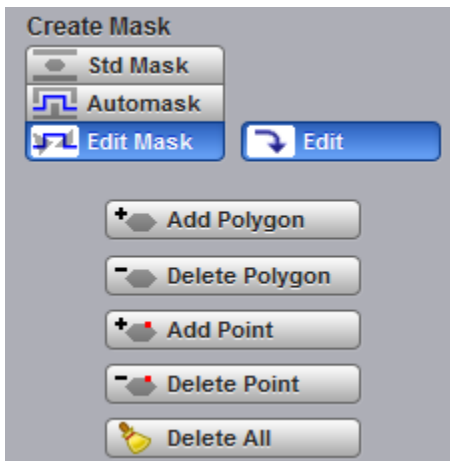

The **Edit Mask** function gives you access to a menu that allows you to construct a new mask, or edit an existing one, using the polygon method. The procedure of editing a mask function brings up a set of brief instructions on how to construct a mask.

Mask editing procedure

The following is a simple procedure for editing the **OC48/STM16** standard mask into a user-defined mask.

1. Select the [STM16/OC48](#) standard mask from [Standard](#) and **Mask** menus.

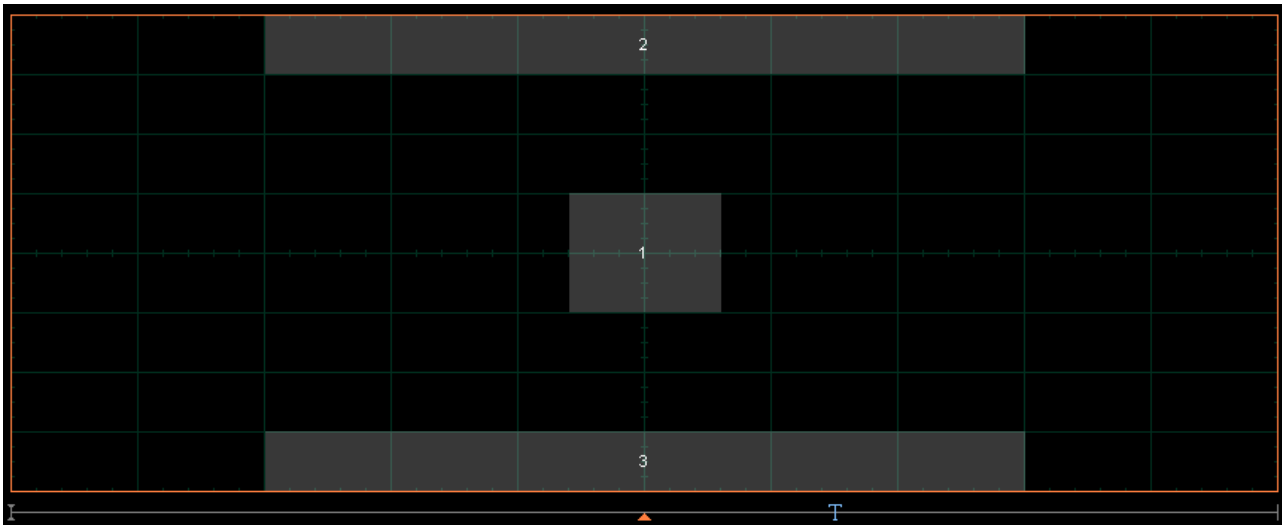

2. Click **Edit Mask** from **Create Mask** menu. Then click **Edit**  **Edit**.

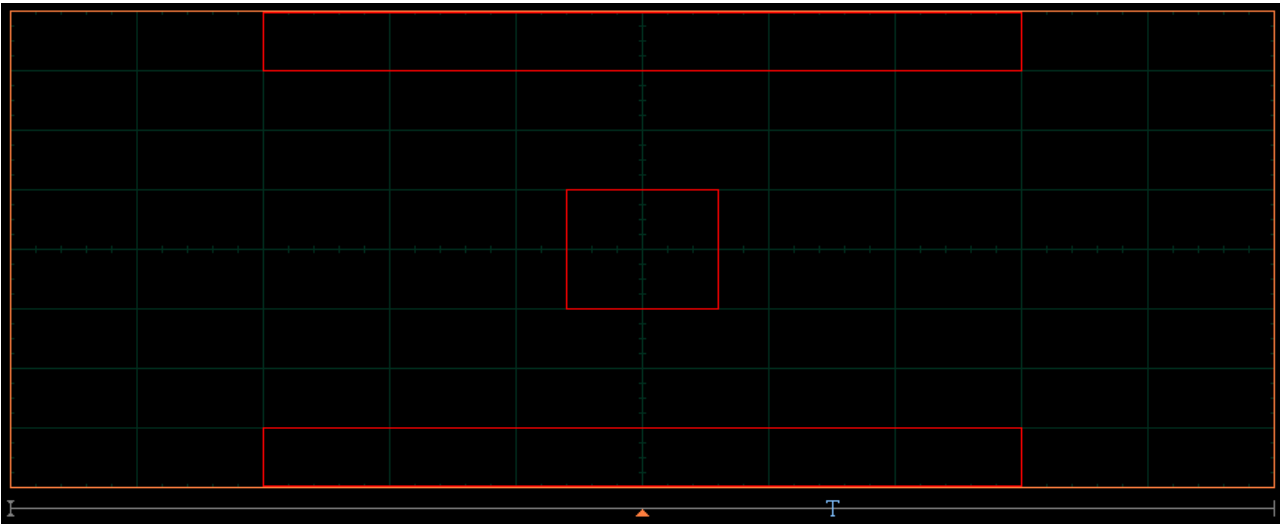

3. Click a polygon to select it, and click again on a vertex of the polygon. Note the square points on the selected polygon, which are yellow when selected, otherwise blue.

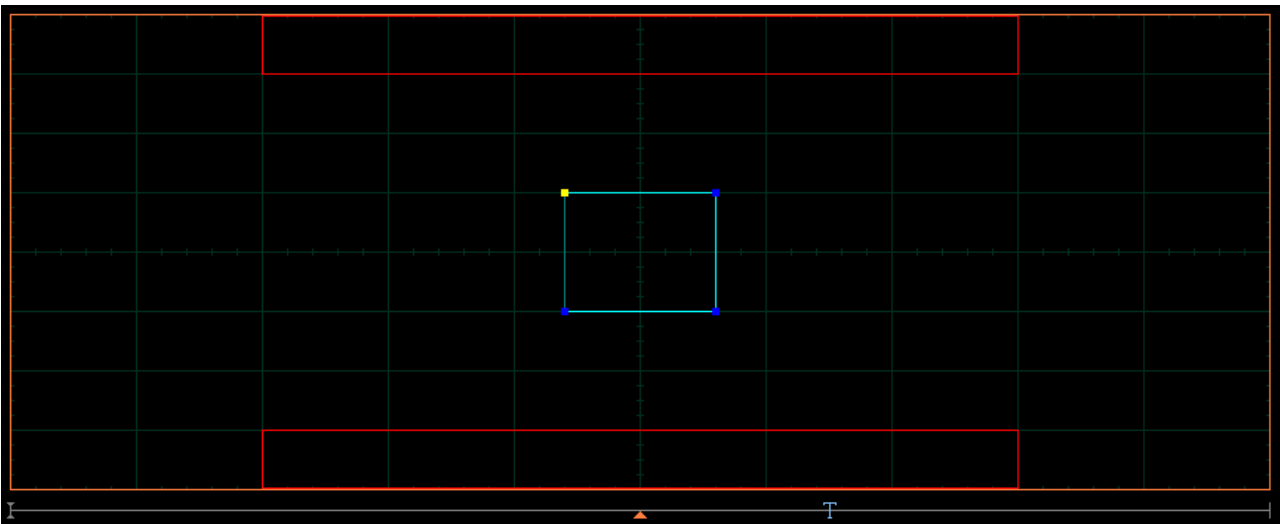

4. Click and hold the left mouse button on the selected point, then drag the mouse to move the point to the desired position. Release the mouse button when finished.

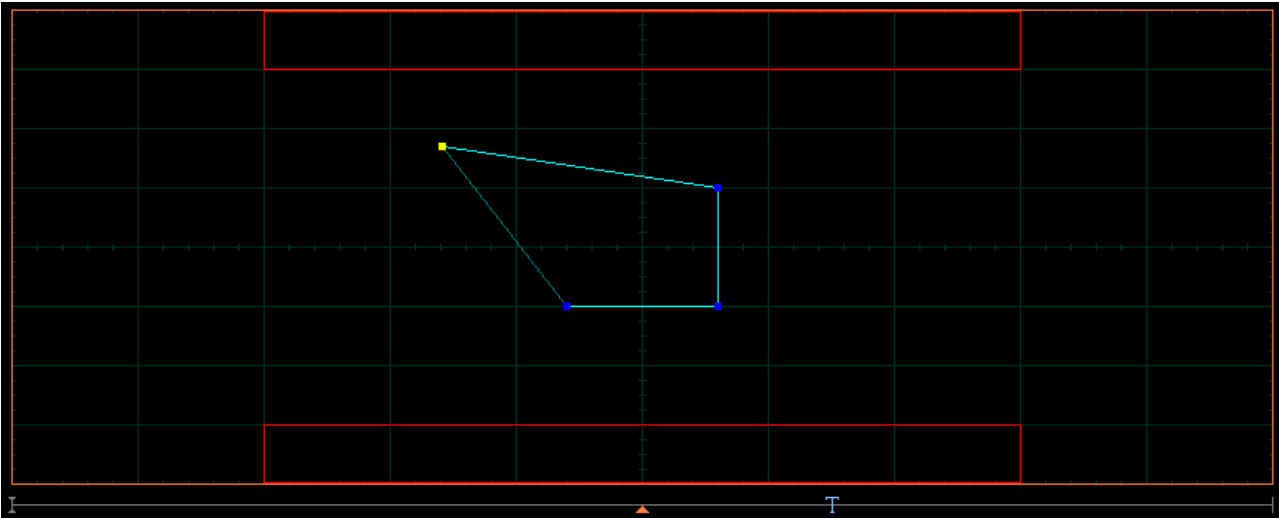

5. Click off the **Edit** button to get the edited mask as shown in the figure below.

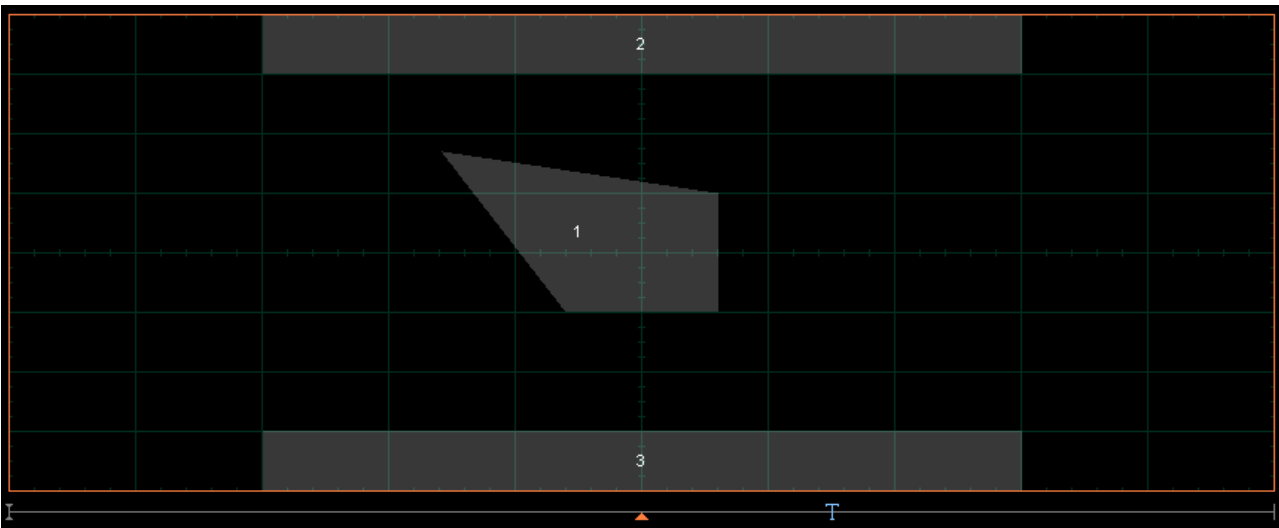

7.7.3.4.1 Add Polygon

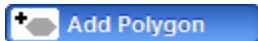

The **Add Polygon** function allows you to select one of the eight polygons that you want to create.

To add a polygon:

1. Click **Edit Mask** from **Create Mask** menu. Then click **Edit** A blue button with a white circular arrow icon and the text "Edit".

2. Click the **Add Polygon** button. To create the first point of the new polygon, click on the waveform area of the screen. Move the mouse to the second point of the new polygon, then click again. Continue for all new points. You will see lines connecting all the points of the polygon. To finish the construction, right-click anywhere on the display. The polygon is now built, and the mouse is free.

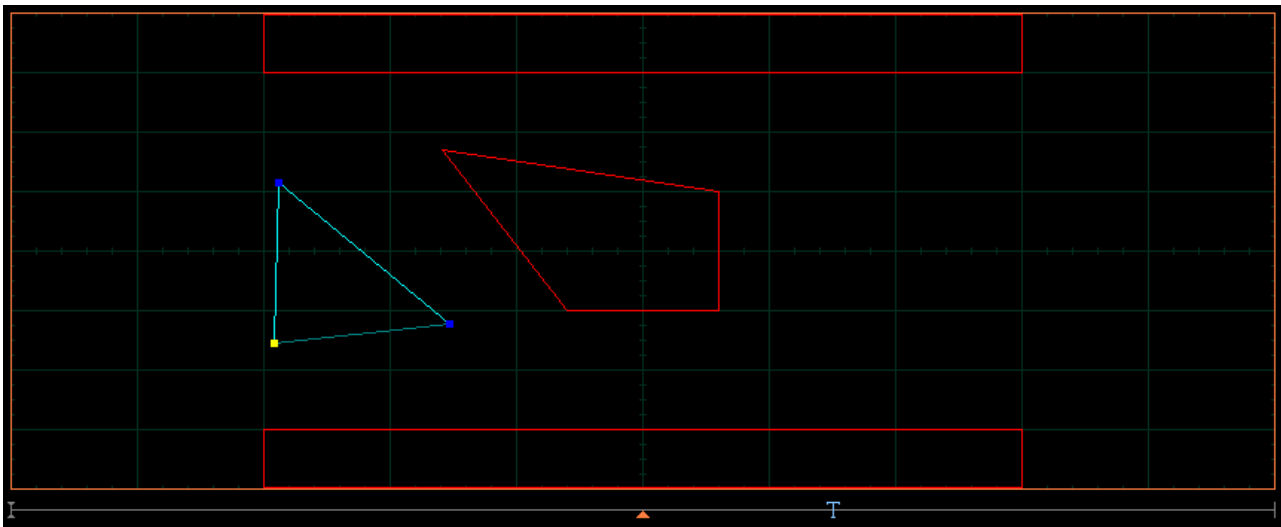

2. Click off the **Edit** button to get a mask with a new polygon. You may have up to eight polygons (see figure below).

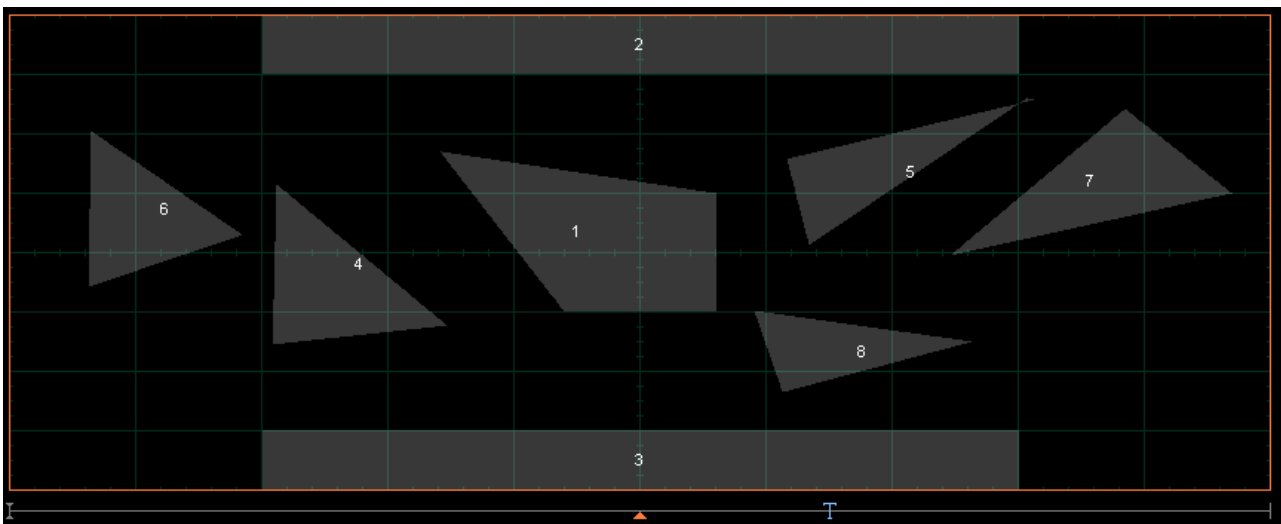

7.7.3.4.2 Delete Polygon



The **Delete Polygon** function allows you to delete one of the eight polygons.

To delete a polygon:

1. Click **Edit Mask** from **Create Mask** menu. Then click **Edit** . Click on any vertex of the polygon you want to delete.

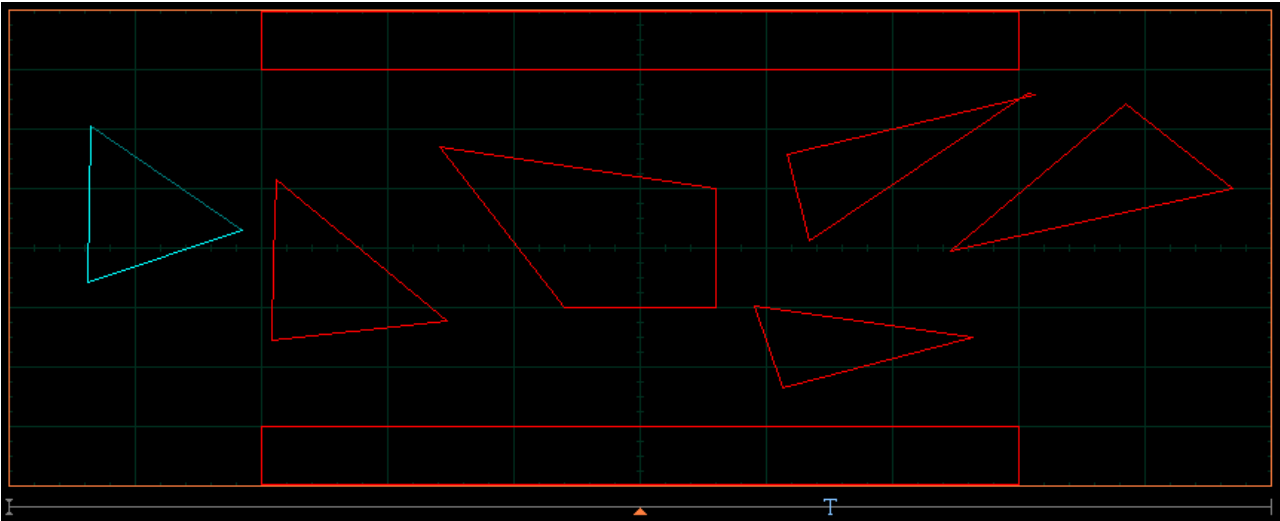

2. Click the **Delete Polygon** button. You will see the mask without the deleted polygon.

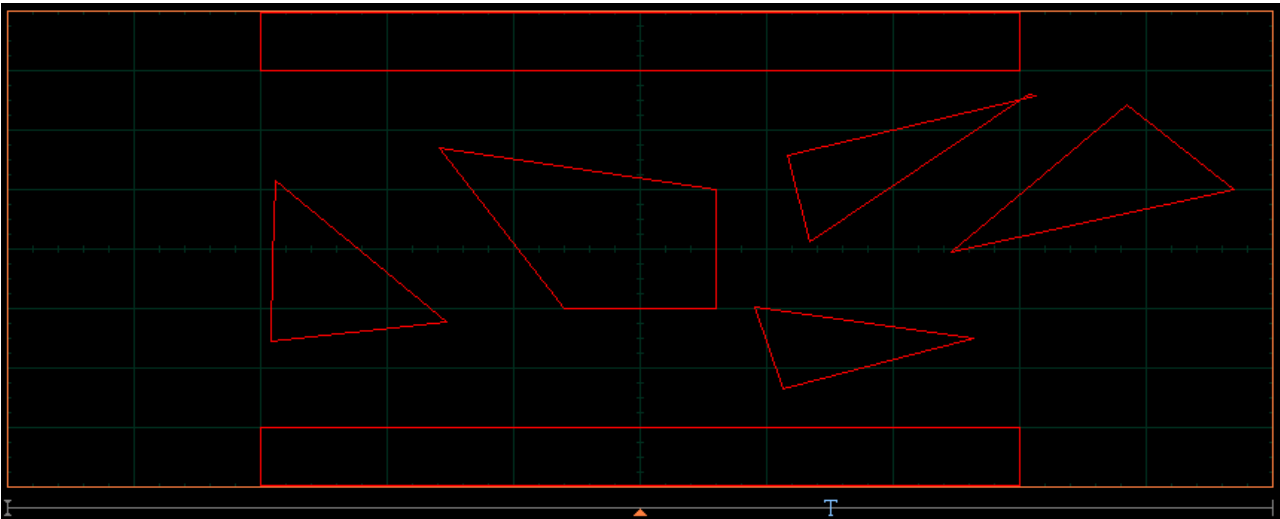

3. Click off the **Edit** button to get a mask without the deleted polygon (see figure below).

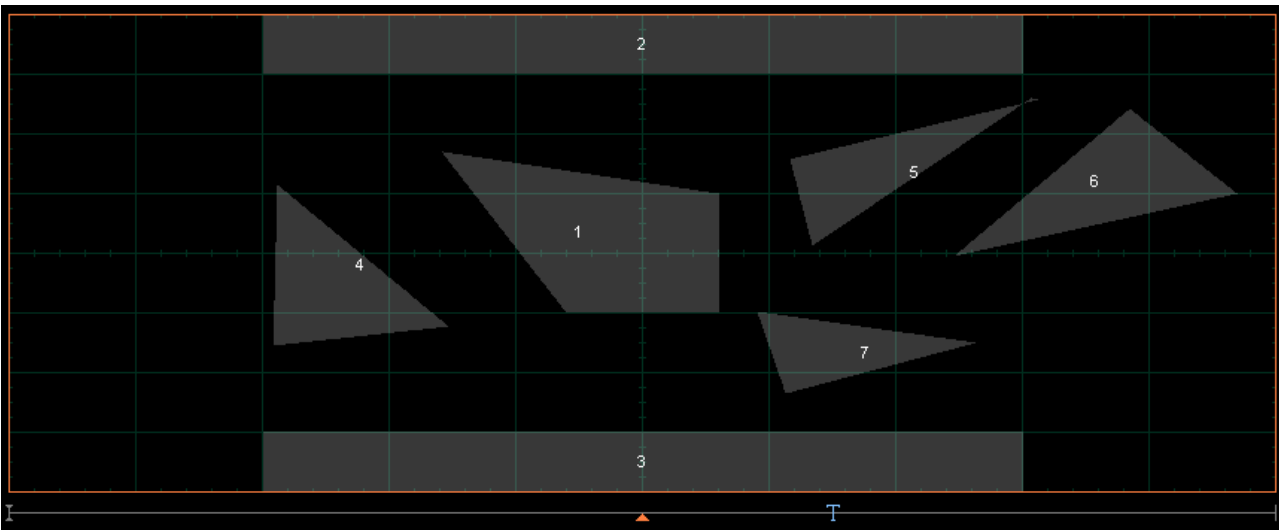

7.7.3.4.3 Add Point

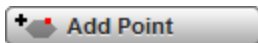

The **Add Point** function adds a point on the selected polygon in a **Mask**.

To add a point:

1. Click **Edit Mask** from the **Create Mask** menu. Then click **Edit** . Click on the polygon that you want to edit, and then click on a vertex of the polygon.

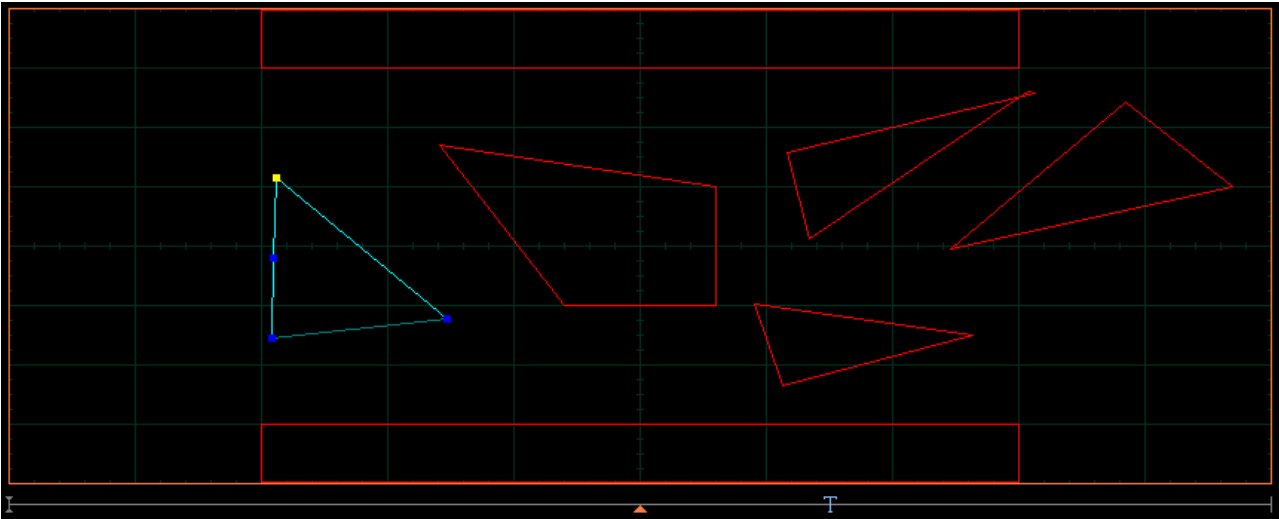

2. Click **Add Point**. A new point, highlighted in yellow, will appear counter-clockwise of the selected point. You can continue to edit this point.

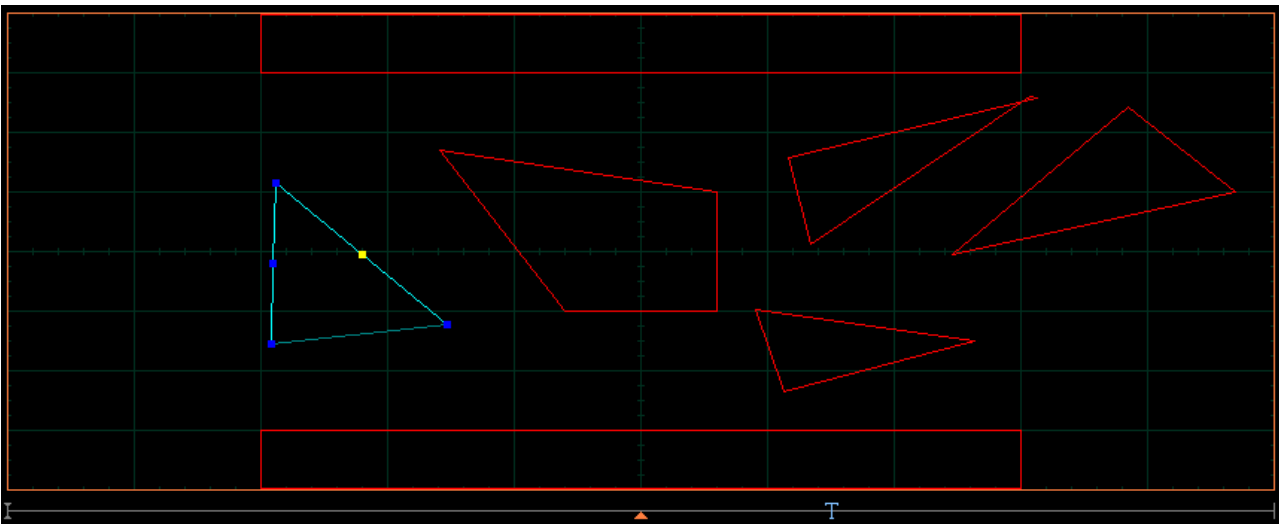

3. Click and hold the left mouse button on the new point, then drag the mouse to move it to the desired position. Release the mouse button when finished.

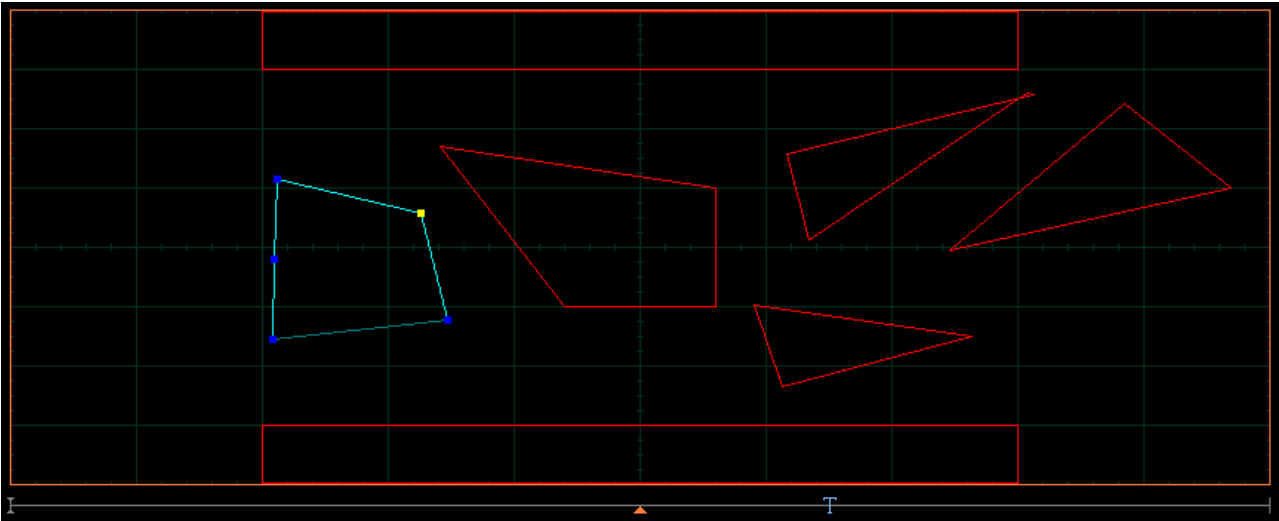

4. Click off the **Edit** button to get a mask with a polygon having an additional point (see figure below).

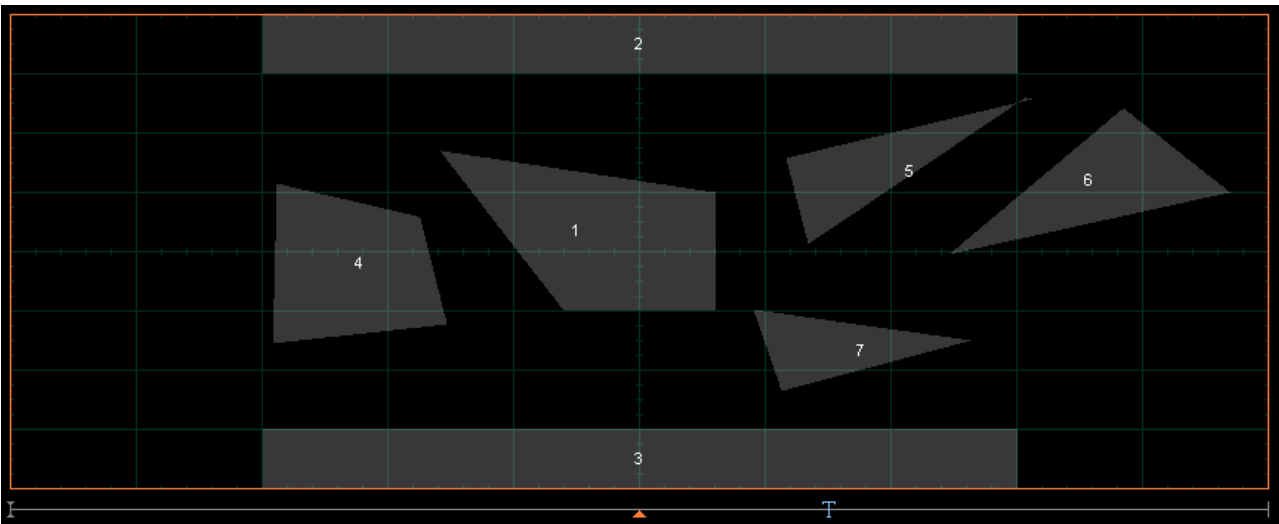

7.7.3.4.4 Delete Point



The **Delete Point** function deletes a point on a selected polygon of a **Mask**.

To delete a point:

1. Click **Edit Mask** in the **Create Mask** menu. Then click **Edit** . Click on the polygon that you want to edit, and then click on a vertex of the polygon.

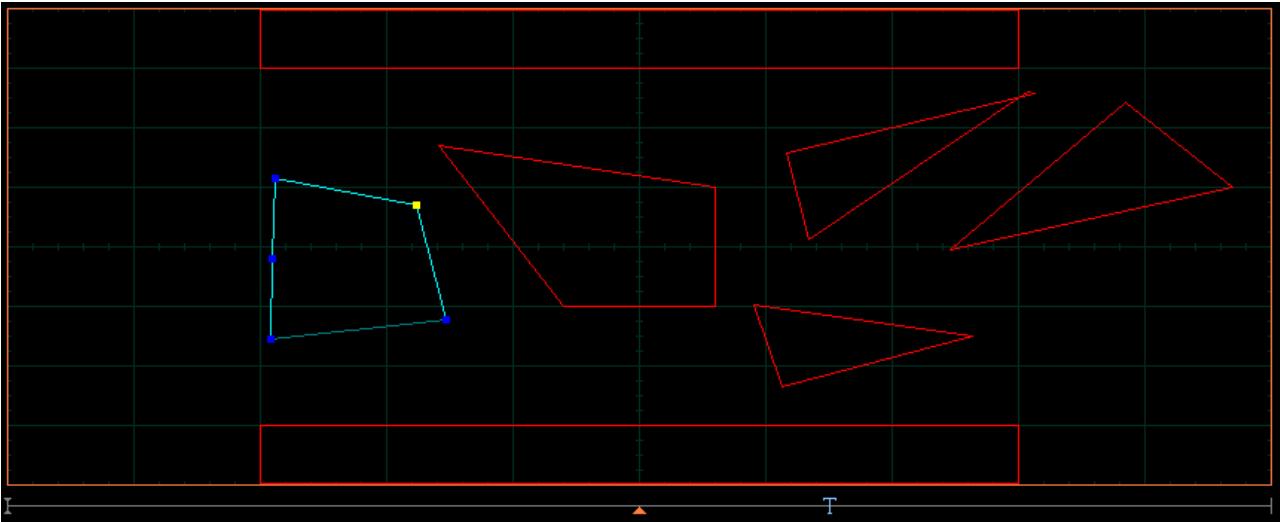

2. Click the **Delete Point** button. The point will be deleted.

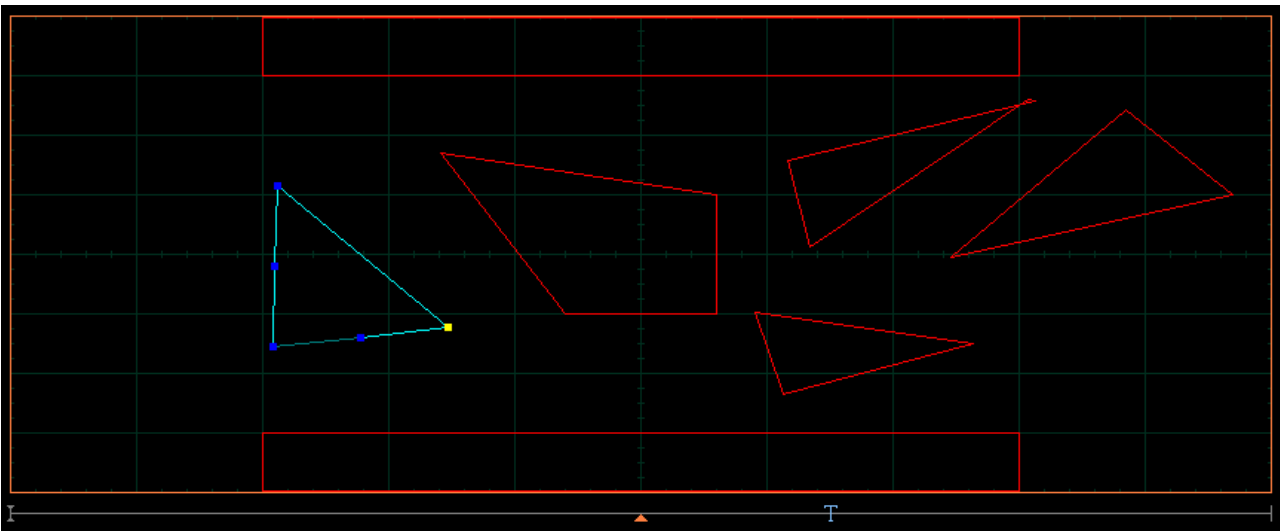

3. Click off the **Edit** button to get a mask with the modified polygon (see figure below).

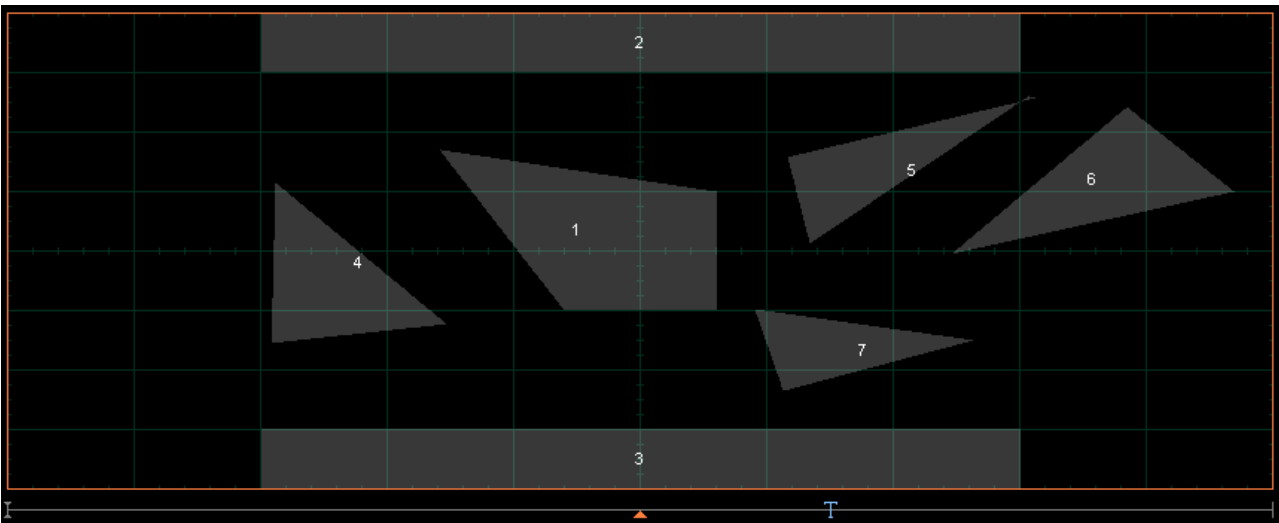

7.7.3.4.5 Delete All



The **Delete All** function allows you to delete the mask that you are editing.

To delete a mask with all polygons:

1. Click **Edit Mask** in the **Create Mask** menu. Then click **Edit**  **Edit**.
2. Click **Delete All**. You will see the screen without masks.

7.7.4 Run Until

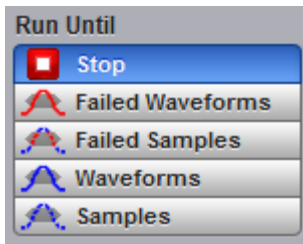

The five choices are:

- **Stop** Run the test until the Stop button is pressed.
- **Failed Waveforms** Run until a set number of failed waveforms occur.
- **Failed Samples** Run until a set number of failed samples occur.
- **Waveforms** Run until a set number of waveforms occur.
- **Samples** Run until a set number of samples occur.

Stop

The **Stop** function runs a mask test until the **Stop** button is pressed. Use **Stop** mode when you want the mask test to run continually and not stop after a fixed number of failures or acquisitions. For example, you may want the mask test to run overnight and not be limited by a number of failures or acquisitions.

Failed Waveforms

The **Failed Waveforms** function runs the mask test until a set number of failed waveforms are acquired. When **Failed Waveforms** is selected you can set the number of failures from the [# of Failed Wfms](#) variable.

Failed Samples

The **Failed Samples** function runs the mask test until a set number of failed samples are acquired. When **Failed Samples** is selected you can set the number of failed samples from the [# of Failed Smpls](#) variable.

Waveforms

The **Waveforms** function runs the mask test until a set number of waveforms are acquired. When **Waveforms** is selected you can set the number of waveforms from the [# of Waveforms](#) variable.

Samples

The **Samples** function runs the mask test until a set number of samples are acquired. When **Samples** is selected you can set the number of samples from the [# of Samples](#) variable.

7.7.5 # of Failed Wfms, # of Failed Smpls, # of Waveforms and # of Samples



When **Failed Waveforms** in the **Run Until** menu is selected, the **# of Failed Wfms** variable sets the number of failed waveforms. After this number is reached, acquisition stops.

When **Failed Samples** in the **Run Until** menu is selected, the **# of Failed Smpls** variable sets the number of failed samples. After this number is reached, acquisition stops.

When **Waveforms** in the **Run Until** menu is selected, the **# of Waveforms** variable sets the number of waveforms. After this number is reached, acquisition stops.

When **Samples** in the **Run Until** menu is selected, the **# of Samples** variable sets the number of samples. After this number is reached, acquisition stops.

7.7.6 Select Action

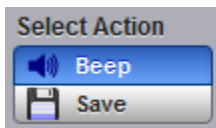

One of two actions can be selected.

Beep

Beep produces an audio tone when any failure occurs.

Save

Save recalls the Windows **Save Waveform As Dialog** that allows you to select the type of format you want to save the waveform as. You can select one of three types of waveform formats:

- Binary format with **.wfm** extension.
- Verbose format with **.txt** extension.
- Y values formats with **.txty** extensions.

When a mask test is started, all waveforms that have data points sampled in the mask regions and margin regions (failures) are stored into the memory in the directory **Mask Test Files**.

7.7.7 Erase Mask

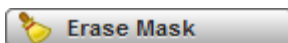

The **Erase Mask** function allows you to erase the mask that is under test.

7.7.8 Recall User Mask



Clicking the **Recall User Mask** button recalls the **Windows Recall Mask** dialog. You can recall a saved mask from any drive on the computer. Saved masks have the extension **.pcm**.

7.7.9 Save User Mask

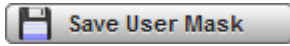

Clicking the **Save User Mask** button recalls the Windows **Save Mask As Dialog**. You can save the mask to any drive on the computer. Saved masks have the extension **.pcm**.

7.8 Mathematics Menu

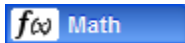

Waveform analysis

Once you have acquired or taken measurements on waveforms, the oscilloscope can mathematically combine them to create a waveform that supports your data-analysis task. For example, you can define math waveforms mathematically (+, -, ×, /). You can also differentiate or integrate a single waveform.

The PicoScope 9404 supports mathematical combination and functional transformation of the waveforms that it acquires. The figure below shows this concept.

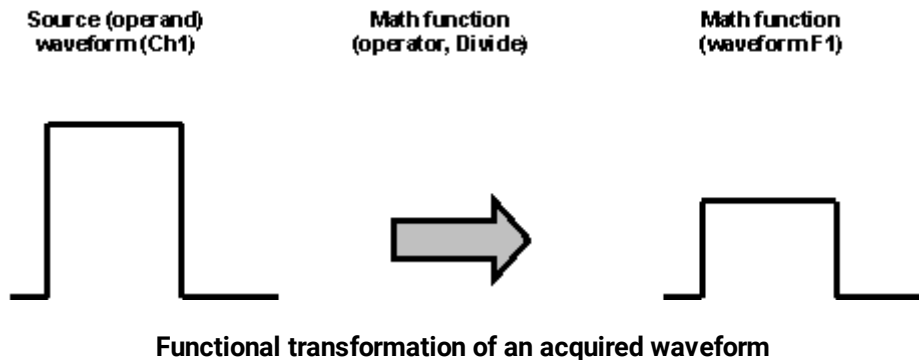

Create math waveforms to support the analysis of your channel and reference waveforms. By combining and transforming source waveforms and other data into math waveforms, you can derive the data view that your application requires.

The **Mathematics** menu allows you to define up to four math functions. Each function consists of a math operator and operands. A function is calculated on data adjusted by the calibration factor from a selected source(s), and a new waveform (called a function) is generated by the computation. You can place markers on functions, make measurements on functions, or store functions to waveform memories.

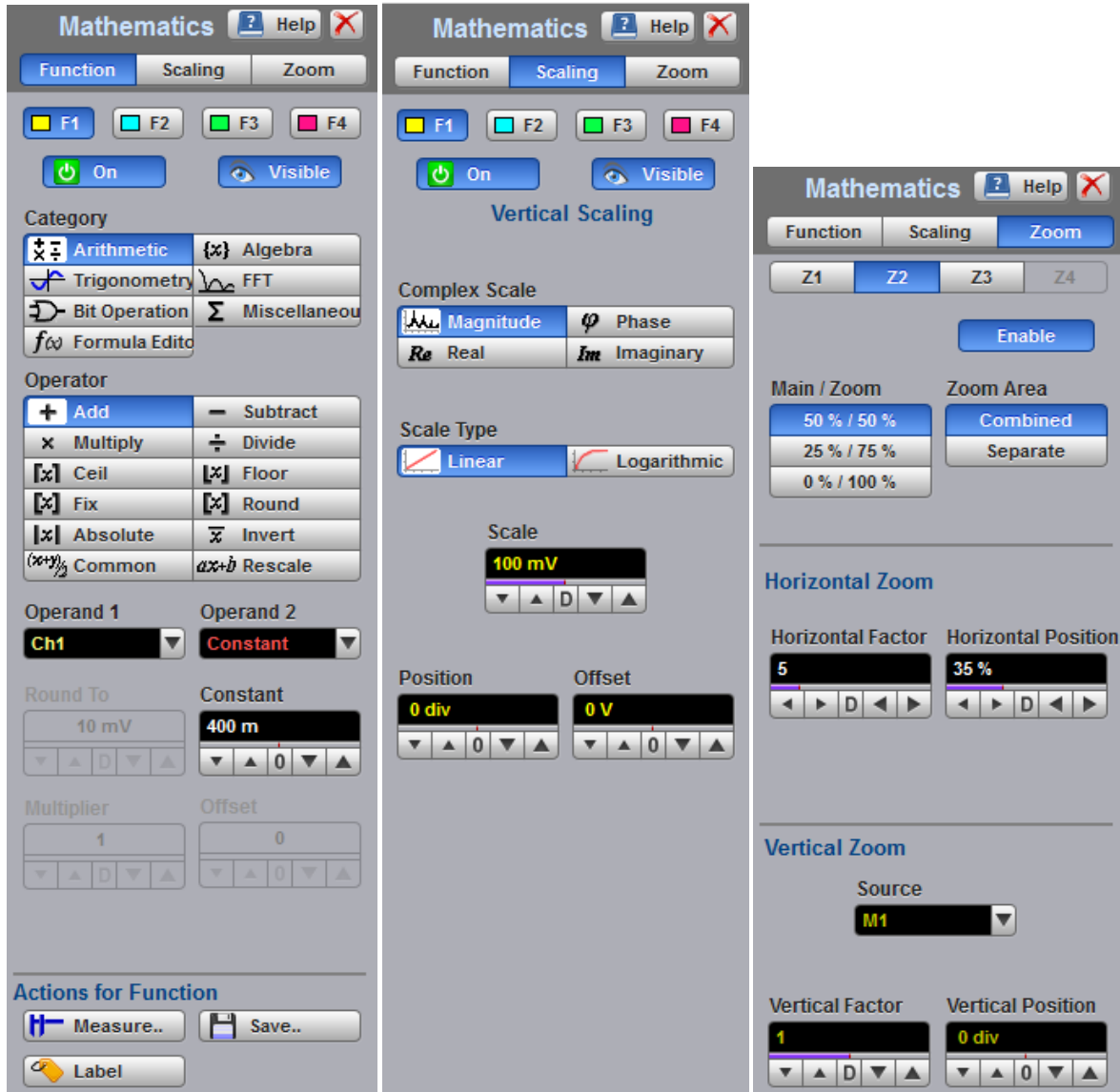

The Mathematics Menu

You can use the waveform math function capabilities to perform math operations on one or more source waveforms. For example, you can subtract channel two from channel one to make a differential measurement. Or, if one channel is measuring current and another channel is measuring voltage, you can use a function to multiply the two channels together and display the instantaneous power as a third waveform. This new waveform can then be measured with markers, or automatic measurements, such as **Peak-Peak** or **AC RMS**.

You can define up to four functions and, in most cases, a function may be used as a source for another function, so the PicoScope 9400 can perform more complex math operations. Select the function you want to define: F1 to F4. Select the operator and source(s) you want to use in the function. If the sources you have selected are active, the scope is triggered, and you will see the display update as you configure the function.

When a function is calculated, it can be displayed on the screen, evaluated with the PicoScope 9400 measurement features, stored in memory or to disk, or used as the source for another function. All math operators, such as invert, subtract, multiply, and divide, are post-processing algorithms so functions are calculated only after their sources have been acquired. All waveform math functions operate on waveform data that is on the display.

7.8.1 Function

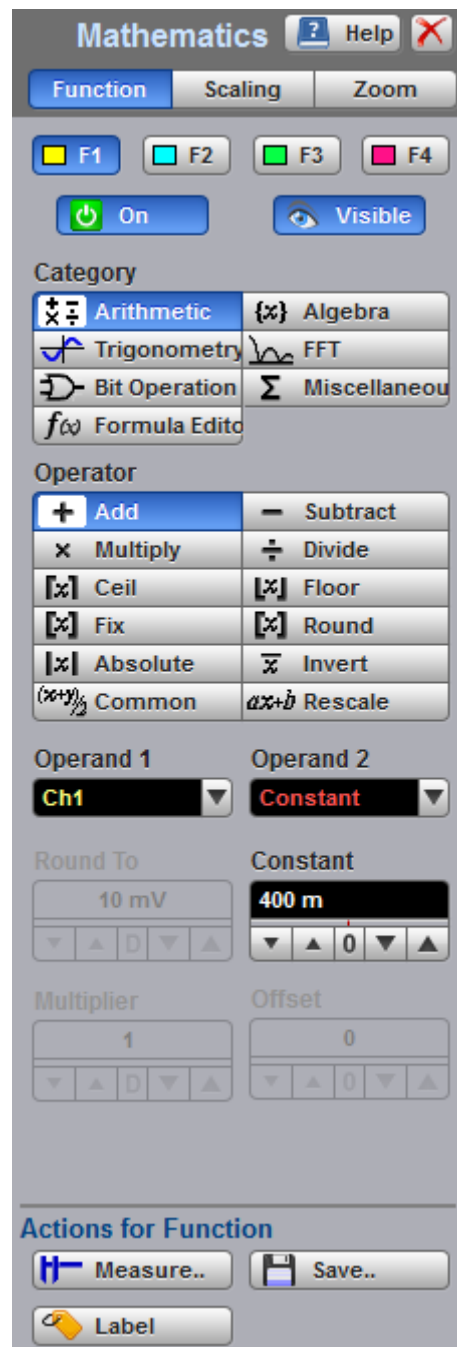

The Math Function Menu

7.8.1.1 Select

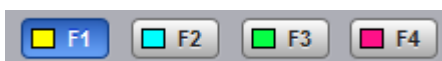

The **Select** menu allows you to select function F1 to F4.

Clicking the F1–F4 options:

- Selects one of the functions.
- Assigns the function soft keys to the selected function.

7.8.1.2 On

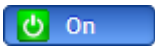

Clicking the **On**:

- Turns the calculation for selected function.
- Changes the label from on to off or vice versa.



You can display all four functions on the screen at the same time.

7.8.1.3 Visible



Clicking the **Visible** button turns the display for the selection on or off. Turning **Visible** off does not turn off the selected function. To turn off the selected function, use the **On** button.

Visible turns on or off the display of selected math waveform. Turning **Visible** off turns off the markers and defines parameters for the histogram window and eye window. However, turning **Visible** off doesn't turn off marker measurements, automatic measurements, histogram measurements, eye-diagram measurements or mask tests.

7.8.1.4 Category

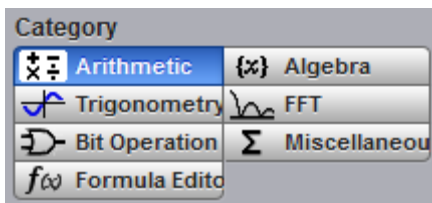

Math functions are grouped by categories. Click on the selected **Category** to see all math operators belonging to that category.

There are seven categories used in the PicoScope 9400 Series:

- Arithmetic
- Algebra
- Trigonometry
- FFT
- Bit Operation
- Miscellaneous
- Formula Editor

7.8.1.5 Operators

Each **Category** has its list of math operators.

You can select any of the math functions as a math operator to act on the operand or operands. To see the resultant waveform, select one from the **Operator** menu. A waveform math operator is a math function that requires one or two, or maybe four, sources. The operators that involve two waveform sources are:

Add, Subtract... The operators that involve one waveform source are: **Invert, Absolute...**

7.8.1.5.1 Arithmetic Operators

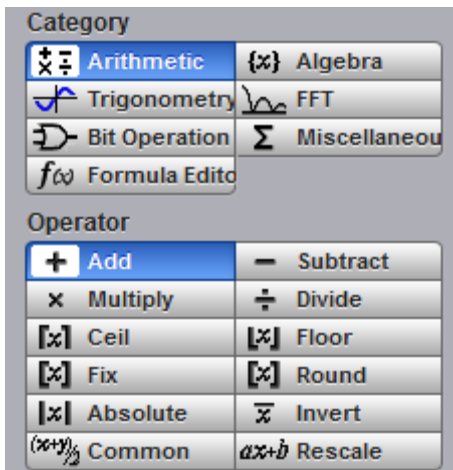

Below is a description of the twelve arithmetic operators.

Add

Adds, point by point, operand 1 and operand 2 voltage values. You can use **Add** to look at the common-mode component of differential waveforms.

Subtract

Subtracts, point by point, operand 2 from operand 1. You can use **Subtract** to make a differential measurement or to compare two waveforms.

Multiply

Multiplies, point by point, operand 1 and operand 2. Use **Multiply** to make electrical power measurements.

Divide

Divides, point by point, operand 1 by operand 2 voltage values. You can use **Divide** to measure the ratio of any two signals, for example the output voltage divided by the input voltage of an amplifier circuit.

Ceil

The **Ceil** function takes the smallest integer not less than the expression. You can use the **Round To** control.

Floor

The **Floor** function takes the largest integer not greater than the expression. The oscilloscope takes a lowest Y value for each X coordinate. You can use the **Round To** control.

Fix

The **Fix** function returns the integer portion of a number. You can use the **Round To** control.

Round

The **Round** function is used to round a numeric field to the number of decimals specified. You can use the **Round To** control.

Absolute

The **Absolute** value function makes positive all vertical values of the waveform data points on operand 1. The results provide the vertical plot data for a waveform. The horizontal scale is not changed.

Invert

Inverts the voltage values, point by point, of the waveform on operand 1. You can use **Invert** to compare the input and output of an inverting amplifier.

Common

The **Common** operation adds operand 1 and operand 2 voltage values and divides by 2, point by point.

Rescale

This function rescales the source values by a factor a and an offset b ($Y=aX+b$).

7.8.1.5.2 Algebraic Operators

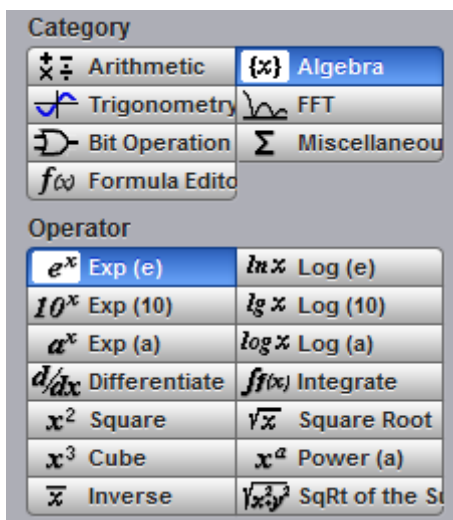

Below is a description of the fourteen algebraic operators.

Exponent (e)

The natural logarithm base e is raised to an exponent equal to the vertical value of a waveform data point of operand 1. Thus **Exponent (e)** exponentiates each point of the waveform. The results provide the vertical plot data for a waveform. The horizontal scale is not changed.

Exponent (10)

The base 10 is raised to an exponent equal to the vertical value of a waveform data point of operand 1. Thus **Exponent (10)** exponentiates each point of the waveform. The results provide the vertical plot data for a waveform. The horizontal scale is not changed.

Exponent (a)

The base a is raised to an exponent equal to the vertical value of a waveform data point of operand 1. Thus **Exponent (a)** exponentiates each point of the waveform. The results provide the vertical plot data for a waveform. The horizontal scale is not changed. Use the **Base** control to select the a value.

Logarithm (e)

Takes the natural logarithm (base e) of the absolute vertical value of each waveform data point of operand 1. The natural logarithm results provide the vertical plot data for a waveform. The horizontal scale is not changed.

Logarithm (10)

Takes the base-10 logarithm of the absolute vertical values in the waveform record of operand 1. The results provide the vertical plot data for a waveform. The horizontal scale is not changed.

Logarithm (a)

Takes the base-a logarithm of the absolute vertical values in the waveform record of operand 1. The results provide the vertical plot data for a waveform. The horizontal scale is not changed. Use the **Base** control to select the a value.

Differentiate

Calculates the discrete derivative of the vertical value of the waveform data points of operand 1. You can use **Differentiate** to measure the instantaneous slope of a waveform. The horizontal scale is not changed. This may be used to measure, for example, the slew rate of an operational amplifier.

Integrate

Calculates the integral of the vertical values of the waveform data points of operand 1. The results provide the vertical plot data for a waveform. The horizontal scale is not changed. This function can be used to calculate the area in volt-seconds under a pulse or other waveform.

Square

The **Square** operator calculates the square of the input signal.

Square Root

The **Square Root** operator calculates the square root of operand 1.

Cube

The **Cube** operator calculates the cube of the input signal.

Power (a)

The **Power (a)** operator calculates operand 1 raised to the power of a. Use the **Exponent** control to select the a value.

Inverse

The **Inverse** operator calculates the function $Y = 1/X$.

Square Root of the Sum

The **Square Root of the Sum** operator calculates the square root of the sum of the squares of two signals.

7.8.1.5.3 Trigonometric Operators

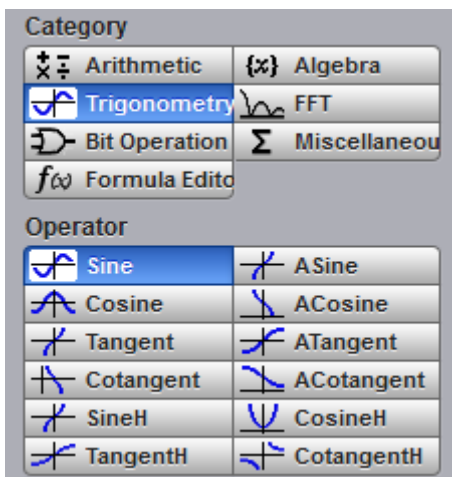

Below is a description of the twelve trigonometric operators. There are four standard trigonometric functions, four inverse trigonometric functions, and four hyperbolic functions.

You can use the **Radian/Vert div** control with many of the trigonometric operators to set the scaling of vertical divisions to radians.

Sine

The **Sine** operator calculates the function $Y = \sin X$, where X is defined by the **Radian/Vert Unit** (V, A, W) control.

Cosine

The **Cosine** operator calculates the function $Y = \cos X$, where X is defined by the **Radian/Vert Unit** (V, A, W) control.

Tangent

The **Tangent** operator calculates the function $Y = \tan X$, where X is defined by the **Radian/Vert Unit** (V, A, W) control.

Cotangent

The **Cotangent** operator calculates the function $Y = \cot X$, where X is defined by the **Radian/Vert Unit** (V, A, W) control.

ArcSine

The **ArcSine** operator calculates the function $Y = \arcsin X$, where X is defined by the **Radian/Vert Unit** (V, A, W) control.

ArcCosine

The **ArcCosine** operator calculates the function $Y = \arccos X$, where X is defined by the **Radian/Vert Unit** (V, A, W) control.

ArcTangent

The **ArcTangent** operator calculates the function $Y = \arctan X$, where X is defined by the **Radian/Vert Unit** (V, A, W) control.

ArcCotangent

The **ArcCotangent** operator calculates the function $Y = \operatorname{arccot} X$, where X is defined by the **Radian/Vert Unit** (V, A, W) control.

SineH

The **SineH** operator calculates the hyperbolic sine function $Y = \sinh(X)$.

CosineH

The **CosineH** operator calculates the hyperbolic cosine function $Y = \cosh(X)$.

TangentH

The **TangentH** operator calculates the hyperbolic tangent function $Y = \tanh(X)$.

CotangentH

The **CotangentH** operator calculates the hyperbolic cotangent function $Y = \coth(X)$.

7.8.1.5.4 FFT

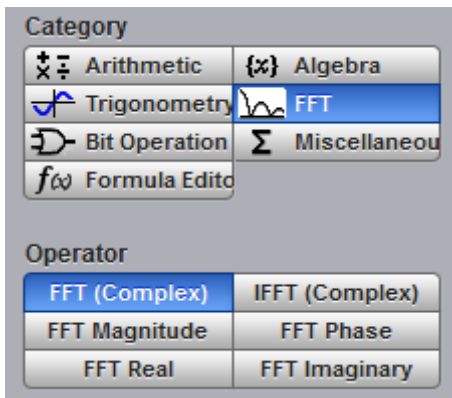

The **FFT** menu allows you to control the operation of the FFT (Fast Fourier Transform), including spectrum selection and display, and also a choice of six FFT windowing functions. Refer to the **Scaling** menu for formatting a spectrum with different complex scales, and also for scaling and positioning it.

7.8.1.5.4.1 FFT Basics

The PicoScope 9400 Series displays and measures signals in the time domain where the vertical axis is amplitude and the horizontal axis is time. This is the best way to view most waveforms. However, there are times when you want to know the frequency content of a waveform.



In 1807 the French mathematician Jean Baptiste Fourier developed the Fourier series and Fourier transform to solve thermodynamics problems. Using the Fourier series, any periodic waveform can be constructed by adding a DC term to a series of sine and cosine terms. You can use the Fourier transform to mathematically relate the time domain and the frequency domain.

The Discrete Fourier Transform (DFT) is used to convert sampled time domain waveform data into the frequency domain. However, the DFT is slow because it requires a large number of calculations. This led to the development of the Fast Fourier Transform (FFT), which runs faster than the DFT on digital computers.

When an FFT, or fast Fourier transform, is added to an instrument, signals can also be displayed in the frequency domain. The frequency domain allows you to see the frequency content of a signal. FFT functionality added to an instrument allows you to analyze a signal from two different, but complementary, points of view: the frequency domain and the time domain. The FFT process mathematically converts the standard (in this case repetitive) time-domain signal into its frequency components, providing spectrum analysis capabilities. Being able to quickly look at a signal's frequency components and spectrum shape is a powerful research and analysis tool.

FFT is an excellent troubleshooting aid for:

- Finding crosstalk problems.
- Finding distortion problems in analog waveforms caused by non-linear amplifiers.
- Adjusting filter circuits designed to filter out certain harmonics in a waveform.
- Testing impulse responses of systems.
- Identifying and locating noise and interference sources.

The FFT display shows the amplitude for each frequency component in your waveform on the vertical axis, and frequency on the horizontal axis. The figure below illustrates what an FFT does. The FFT transforms a time record of N samples into a frequency record of N points from 0 Hz to F_s , where F_s is the sampling frequency. The resolution or the spacing between the points in the frequency record is F_s/N .

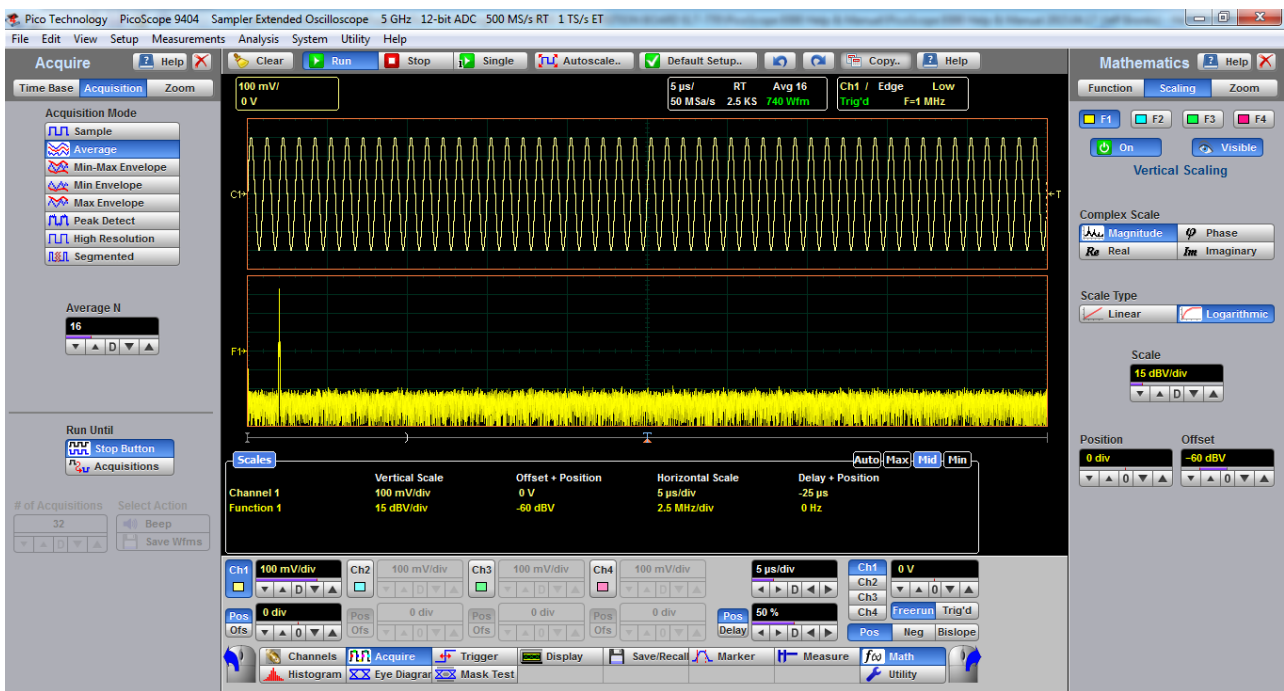

The 1 MHz sine-wave signal shown in both the Time Domain and the Frequency Domain

The frequency $F_s/2$ is a unique frequency referred to as the Nyquist frequency. At the Nyquist frequency there are exactly two samples on every cycle of the input signal. Signals above the Nyquist frequency become aliased, which means that they appear as signals of a lower frequency, because there are not enough sample points on each cycle of the signal to determine the correct frequency.

It turns out that the points above $F_s/2$ are mirror images of the points below $F_s/2$. They are not displayed because they do not provide any additional information. Therefore, N time samples results in $N/2$ displayed frequency points.

You can use the FFT capability to display both the magnitude and the phase, or the real and the imaginary parts of the frequency components of the signal, using a linear or decibel vertical scale.



Use the **Scale** menu for further magnification and spanning of the FFT, and for selecting the Complex Scale of the display.

You can perform an FFT on any waveform. The record length of the waveform can be up to 32 768 points. Because the PicoScope 9400 Series performs FFT calculations on a complex trace record, you should use the shortest record length that provides adequate resolution, as FFT waveforms update slowly at long record lengths.

The PicoScope 9400 Series offers a choice of six FFT windowing functions, which modify the time-domain data to minimize “leakage” of energy across frequency components.

The five automated measurements FFT Magnitude, FFT Delta Magnitude, THD (Total Harmonic Distortion), FFT Frequency, and FFT Delta Frequency are intended for FFT waveforms. You can also use the markers to make magnitude and phase measurements on frequency domain traces.



Use the **Measure** and **Marker** menus for further spectral measurements of FFT waveforms.

FFT Resolution**Amplitude Resolution**

Amplitude resolution is influenced by the windowing function used and the vertical adjustment of the time domain waveform. For maximum amplitude resolution, the time domain waveform should be adjusted so that it is centered vertically on the graticule and is tall as possible without going beyond the graticule, above or below.

Frequency Range and Resolution

The range and resolution of the frequency spectrum displayed by the PicoScope 9400 Series are determined by the sample rate and record length. The sample interval is determined by the timebase and record length. You can increase the record length for better FFT resolution but all points must be on the display for them to be included in the FFT calculation. The FFT calculation time will also increase because more waveform samples must be processed.

The FFT's resolution is expressed as follows:

$$\text{FFT Resolution} = \text{Effective sample rate} / \text{Record length}$$

The FFT frequency range before scaling will be from 0 Hz to one half of the sample rate. Ensure that the sample rate is at least twice the highest anticipated frequency component of the waveform source you are measuring. Otherwise, the measurement results will exhibit aliasing and any measurements will be inaccurate.

The FFT's frequency range is expressed as follows:

$$\text{FFT Frequency Range} = \text{Effective sample rate} / 2$$

FFT Aliasing

Aliasing occurs when the input signal includes components at frequencies higher than the Nyquist frequency. These frequency components appear in the FFT waveform display as peaks at lower frequency. The higher-frequency components are reflected around the Nyquist frequency. For example, a frequency component 1 GHz above the Nyquist frequency will appear as a peak 1 GHz below the Nyquist frequency in the FFT waveform display.

You can eliminate aliasing by setting the effective sampling rate to be at least twice the highest frequency in the input signal. Increasing the record length or decreasing the timebase scale will increase the effective sampling rate.

7.8.1.5.4.2 FFT Operators

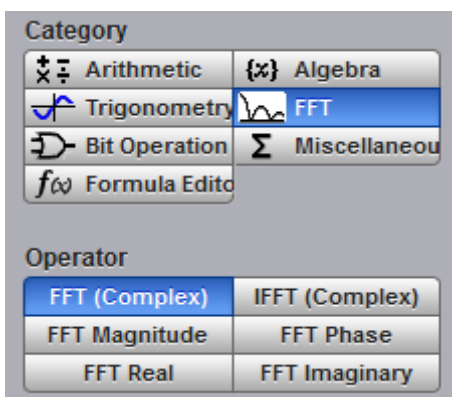

Below is a description of the six FFT operators.

FFT (Complex)

The **FFT (Complex)** operator calculates the function $Y = \text{FFT}(X)$. This is a complex function that can be used as a source for a further **Inverse FFT**. The **Scaling/Complex Scale** menu provides selection of the display format of a waveform that has a complex value. You can select either **Magnitude, Phase, Real** or **Imaginary** complex scale.

Inverse FFT (Complex)

Inverse FFT calculates the time-domain function from its frequency-domain data (spectrum). Only a complex function can be used as a source for **Inverse FFT**.

FFT Magnitude

The peak signal amplitude is represented on a linear scale, in the same units as the input signal. You can choose **Vertical Zoom, Vertical Position, Horizontal Zoom** and **Horizontal Position** to provide complete control over the spectrum magnitude.

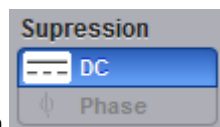

Use the **DC Suppression** option to reduce the DC components in the FFT spectrum of the signal.

FFT Phase

The **FFT Phase** is measured with respect to a cosine whose maximum occurs at the left-hand edge of the screen, at which point it is 0° . Similarly, a positive-going sine wave starting at the left-hand edge of the screen has a -90° phase. You can display phase data as a function of frequency in degrees.

Your source waveform record may have a noise component with phase angles that randomly vary from $-$ to $+$. This noise could make the phase display unusable. In such a case, use phase suppression to control the noise. You can reduce the noise phase for magnitudes below a threshold level by using the **Phase Suppression** and **Suppression Level** controls. The **Suppression Level** control allows you to adjust the phase suppression level. You specify the phase suppression level in dB with respect to a peak having maximum amplitude among other peaks. If the magnitude of the frequency is greater than this threshold, then its phase angle will be displayed. FFT magnitudes below this level will have their phase set to zero.

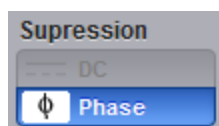

Phase suppression controls

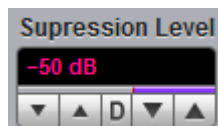

Suppression level controls

FFT Real

The **FFT Real** operator displays the linear magnitude of the real part of the spectral magnitude only. This is useful if you process the spectrum off-line and transform it back into a time-domain trace. You could save the real spectrum into a waveform memory.

FFT Imaginary

The **FFT Imaginary** operator displays the linear magnitude of the imaginary part of the spectral magnitude only. This is useful if you process the spectrum off-line and transform it back into a time-domain trace. You could save the imaginary spectrum into a waveform memory.

7.8.1.5.4.3 FFT Windows

Windowing is a technique that compensates for some of the limitations of FFT analysis. The FFT operation assumes the time record repeats infinitely. Unless there is an integral number of cycles of the sampled waveform in the record, a discontinuity is created at the end of the record.

A pure sine wave transforms into a single spectral component, but a discontinuity in the time domain causes a frequency-domain widening or spreading out of the waveform, referred to as "spectral leakage". Two figures below show a sine wave FFT with and without leakage.

A solution to the leakage problem is to force the waveform to zero at the beginning and end of the time record so that no transient is present when the time record is replicated. This is done by multiplying the time record by a window function, which produces its own effect in the frequency domain. However, the effect produced by the window function is a big improvement over using no window function at all.

Windowing Process

The process of windowing the data is shown below. The FFT time domain record is multiplied point by point with the FFT window. When the Hann or Blackman/Harris window is used, the data point amplitudes taper to zero at the end of the record.

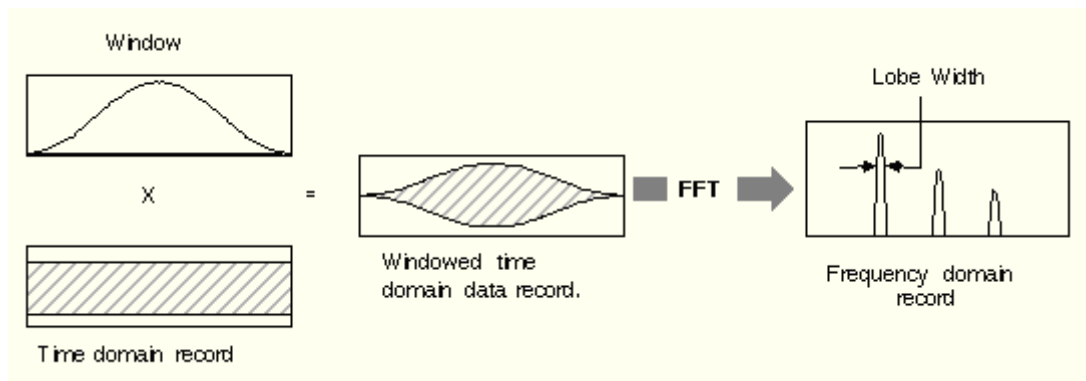

Multiplying the time domain data record by a window



When using windows, be sure that the most interesting parts of the signal in the time domain record are positioned in the centre of the window so the tapering does not cause significant errors.

Types of FFT Window

The window type defines the bandwidth and shape of the equivalent filter associated with the FFT processing. The PicoScope 9400 Series provides a rectangular FFT window, which does not taper the time domain data, and five tapering FFT windows of different shapes.

The six supported FFT window functions are:

- **Rectangular** window
- **Hamming** window
- **Hann** window
- **Flattop** window
- **Blackman-Harris** window
- **Kaiser-Bessel** window



Remember that windows work by weighting points in the middle of the waveform record higher than those at the ends of the record.

Each time-domain FFT windowing function corresponds to a filter in the frequency domain. Each frequency domain filter has a high central lobe, or passband, whose width determines how well adjacent frequency components can be resolved. The height of the side lobes surrounding the central lobe determines how much leakage can occur.

Equations for the FFT Windows

Four windows used in the PicoScope 9400 Series (**Hamming**, **Hann**, **Flattop**, and **Blackman-Harris**) are derived from a cosine series. The window type is obtained by substituting the correct coefficients for the cosine terms into the following equation:

$$f(n) = \sum_{i=0}^m \left\langle a_i \cos\left[\frac{2\pi}{N} \left(n - \frac{N-1}{2}\right)\right] \right\rangle$$

where: n is the window data area, a is the array of window coefficients, N is the window length, m is the window order, i is the index to the window coefficient array, and n is the index to the window data array. $n = 0$ to $N-1$.

The table of correction coefficients for different FFT windows indicates the values to substitute into equation to obtain the various windows.

Correction coefficients for different FFT windows

Coefficients	Rectangular	Hamming	Hann	Flattop	Blackman-Harris	Kaiser-Bessel
M	0	1	1	2	3	3
a0	1.0	0.543478	0.5	0.281	0.35875	0.40243
a1	0.0	0.456522	0.5	0.521	0.48829	0.49804
a2	0.0	0.0	0.0	0.198	0.14128	0.09831
a3	0.0	0.0	0.0	0.0	0.01168	0.00122
Highest side lobe	-13 dB	-43 dB	-32 dB		-94 dB	-69 dB
3 dB Bandwidth in bins	0.89	1.3	1.44		1.92	1.72
Scallop loss	3.96 dB	1.78 dB	1.42 dB		0.81 dB	1.02 dB
Zero Phase Reference	50%	50%	50%		50%	50%

For the Rectangular window: $n = 1$.

The best window for a given application depends on various factors. Most measurements require the use of a window such as the **Hann** or **Flattop** windows, which are the appropriate windows for typical frequency analysis measurements. Choosing between different windows involves a trade-off between frequency resolution and amplitude accuracy.

For harmonic analysis of continuous-time signals, the best window choice depends on the signal characteristics and on the particular characteristics that are of most interest. The use of **Blackman-Harris**, **Kaiser-Bessel**, **Hann** or **Hamming** windows typically makes observation of harmonics easier.

The rectangular window can be typically used for impulse response testing since the beginning points are usually zero and the data tapers to zero at the end of the record. The beginning points are zero because the impulse is normally placed in the centre of the time-domain record at the zero-phase reference point. Other windows can be used if desired. If phase is not important, the impulse can be placed at the beginning of the record. For this case, the window must be **Rectangular**.

The rectangular window (also referred to as the Uniform window) is effectively no window because the samples are left unchanged. All points in the record are multiplied by 1. In the frequency domain, the filter shape is $\sin(x)/x$.

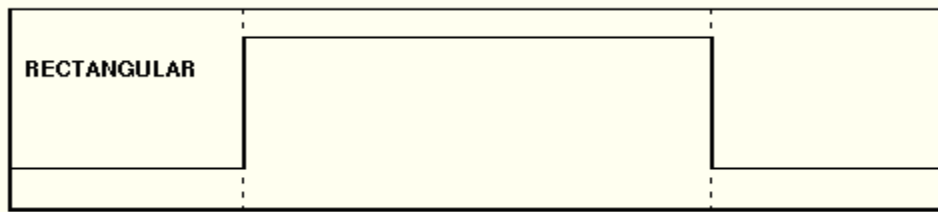

Time-domain characteristics for rectangular window

The rectangular window is useful for transient signals and signals where there are an integral number of cycles in the time record. It is the best window to use when you want to examine the frequency spectrum of a non-repetitive signal. Also, it can be typically used for impulse response testing since the beginning points are usually zero and the data tapers to zero at the end of the record. The beginning points are zero because the impulse is normally placed in the centre of the time domain record at the zero phase reference point. Other windows can be used if desired. If phase is not important, the impulse can be placed at the beginning of the record. For this case, the window must be rectangular.

The rectangular window generally gives the best frequency resolution because it results in the narrowest lobe width in the FFT output record. It gains frequency resolution at the expense of amplitude accuracy if the frequency of the signal being observed has a non-integer number of cycles in the FFT time record. Signals not in this class show varying amounts of spectral leakage and scallop loss, which can be corrected by using one of the other windows.

Although the rectangular window has the potential for severe leakage problems, in some cases the waveform data in the time record has the same value at both ends of the record, thereby eliminating the transient introduced by the FFT. Such waveforms are called self-windowing. Waveforms such as sine bursts, impulses and decaying sinusoids can all be self-windowing.

The **Hamming** window is a bell-shaped window. It has lower side lobes adjacent to the main lobe than, for example, the **Hann** window.

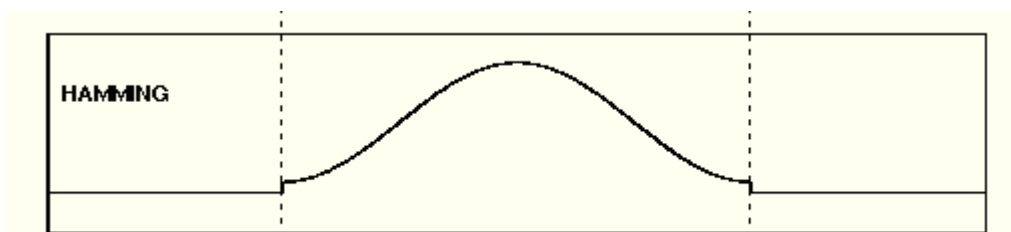

Time-domain characteristics for Hamming window

The **Hamming** window tapers the data to smaller values, but not to zero. It decreases the amount of energy spillover into adjacent frequency bins, increasing the amount of amplitude accuracy at the expense of decreasing the frequency.

Use the **Hamming** window for resolving frequencies that are very close to the same value with somewhat improved amplitude accuracy over the rectangular window.

The **Hann** (or **Hanning**, or **cosine**) window is a bell-shaped window, and it looks like the first half of a sine wave. The **Hann** window multiplies the points in the center of the record by 1 and multiplies the points at the start and the end of the record by zero. It decreases the amount of energy spillover into adjacent frequency bins, increasing the amount of amplitude accuracy at the expense of decreasing the frequency resolution because of wider lobe widths. The shape of the **Hann** window is a compromise between amplitude accuracy and frequency resolution.

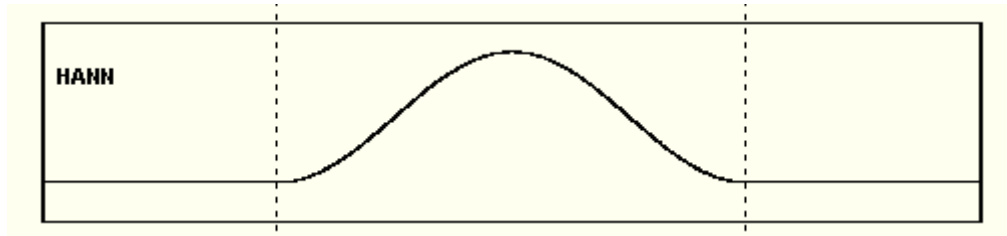

Time domain characteristics for Hann window

The **Hann** window is useful for frequency resolution and general-purpose use. Even though the overall shape of the time-domain signal has changed, the frequency content remains basically the same. The spectral line associated with the sinusoid spreads out a small amount in the frequency domain. It is good for resolving two frequencies that are close together or for making frequency measurements. The **Hann** window also improves amplitude accuracy.

The **Hann** window, compared to other common windows, provides good frequency resolution at the expense of somewhat less amplitude accuracy.

The **Flattop** window has a fatter (and flatter) characteristic in the frequency domain. The flatter top on the spectral line in the frequency domain produces improved amplitude accuracy, but at the expense of poorer frequency resolution when compared with the **Hann** window.

The flattop window is the best window for making accurate amplitude measurements or frequency peaks.

A **Blackman-Harris** window is a bell-shaped window. It reduces the leakage to a minimum, has the widest pass band (lowest frequency resolution) and lowest side lobes. It decreases the amount of energy spillover into adjacent frequency bins, increasing the amount of amplitude accuracy at the expense of decreasing the frequency resolution because of wider lobe widths.

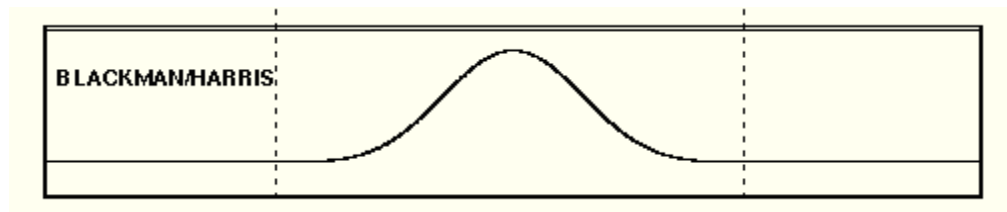

Time domain characteristics for Blackman-Harris window

The **Blackman-Harris** window is the best window for measuring the amplitude of frequencies but worst at resolving frequencies. This window is especially good for viewing a broad spectrum.

This window has resolution bandwidths and scallop losses close to the Blackman-Harris window. Choose the **Kaiser-Bessel** window to view the signal characteristics you are interested in.

7.8.1.5.5 Bit Operation

Bit Operation defines a logical combination of up to four sources. The sources are channels, memories and functions.

Below is a description the of seven bit operations and some auxiliary controls.

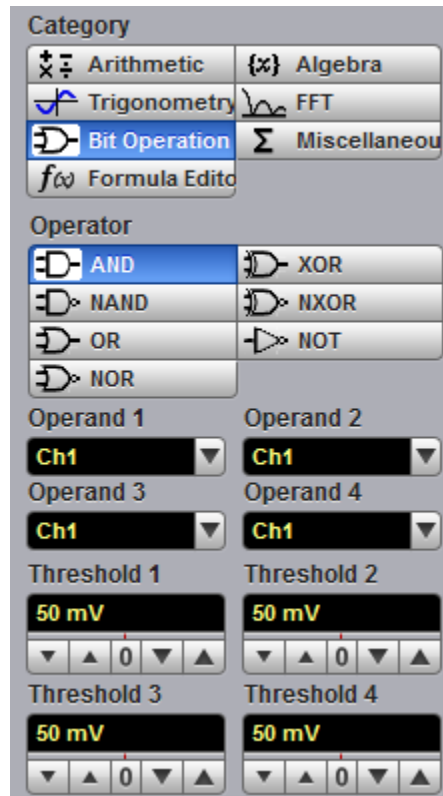

The Bit Operation menu

- **AND** a logical AND, conjunctive combination.
- **NAND** a logical NOT AND.
- **OR** a logical OR, disjunctive combination.
- **NOR** a logical NOT OR.
- **XOR** a logical exclusive OR.
- **NXOR** logical negation of exclusive OR.
- **NOT** a logical negation.

Operand 1 - Operand 4

Up to four sources (operands) can be used to define the logic combination. The sources are channels, memories and functions.

Threshold 1 - Threshold 4

Use these controls to set the threshold level for the logic definition of a 1 (one) or 0 (zero) on any source. Each source can have a threshold level set which determines when a voltage value is considered to be a 1 (one) or 0 (zero). A value is considered a 1 when your waveform's voltage level is greater than the threshold level and a 0 when your waveform's voltage level is less than the threshold level.

Inverse Operand

You can invert the polarity of any source to define the necessary logic combination.

7.8.1.5.6 Miscellaneous Operators

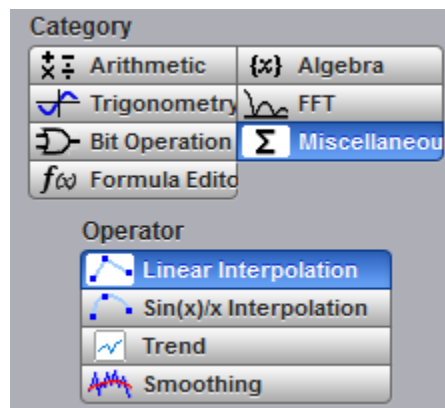

The Miscellaneous Operation menu

Below is a description of the four miscellaneous operators.

Interpolation

When the sample density falls to less than one sample per display column, the oscilloscope can calculate intermediate points to display a waveform. This process is called interpolation.

Linear Interpolation

Draws a line between consecutive waveform data points. It gives an analog look to a digitized waveform. For example, you can see steep edges on waveforms, such as square waves.

Sin(x)/x Interpolation

Uses a $\sin(x)/x$ digital filter that improves the reconstruction of the waveform. The reconstruction is done by adding data points between the acquired data points. This function improves accuracy of measurements. It is important for waveforms that can be bandlimited to $\frac{1}{4}$ of the current effective sample rate.

For each interpolation method use the **Upsample to** control to increase density factor from 2 to 256 points by which to interpolate (upsample).

You can also interpolate waveforms in [Scaling](#) mode where the waveforms can be zoomed and positioned vertically and horizontally.

When the PicoScope 9400 acquires a signal in **Equivalent Time Sampling** mode, the effective sampling rate is very high. For example, a 1 Gb/s signal with 1000 samples per unit interval will have a sample resolution of 1 ps that is equivalent to a 1 THz sampling rate. Normally, interpolation would never be needed. In some cases when a lower number of samples per bit are acquired, interpolation is helpful to view the signal. The interpolation is very helpful for **Real Time** sampling mode.

Trend

Trend represents the evolution of timing parameters as line graphs whose vertical axes are the value of the parameter, and horizontal axes the order in which the values were acquired. The information obtained from applying timing parameters can then be analyzed using the trend.

The following trend parameters can be used: Period, Frequency, Positive Width, Negative Width, Rise Time, Fall Time, Positive Duty Cycle, Negative Duty Cycle. Use the **Trend Parameter** control to select the trend parameter.

Smoothing

This allows reduction of unwanted noise and jitter on the signal with a simple, moving-average filter. N-point smoothing can be done with up to a 51-point filter. The number of points N can be selected by the **Smooth Length** variable.

The **Smooth Length** variable defines the number of points N in the moving-average filter used for the smoothing operator. N-point smoothing can be selected from 3 up to 51 points.

7.8.1.5.7 Formula Editor

The **Formula Editor** option allows you to create an arbitrary function of one or more inputs, waveform memories or other formulas. Click **Edit** to enter a new formula or edit an existing one.

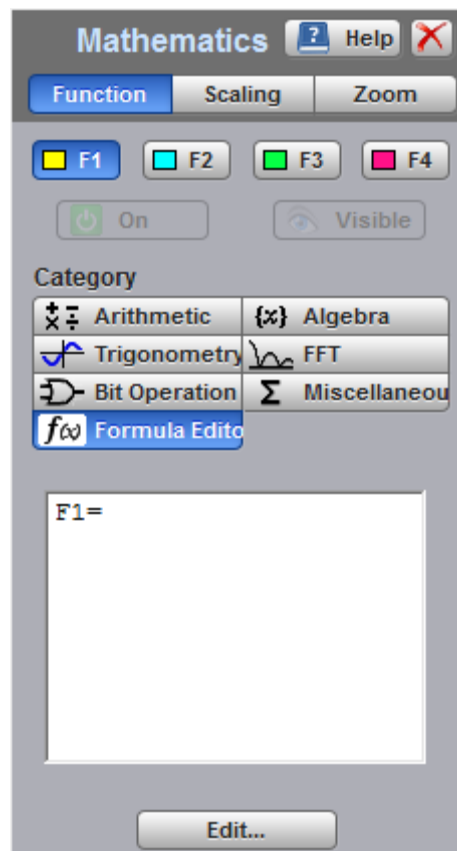

The Mathematics menu with the Formula Editor option selected

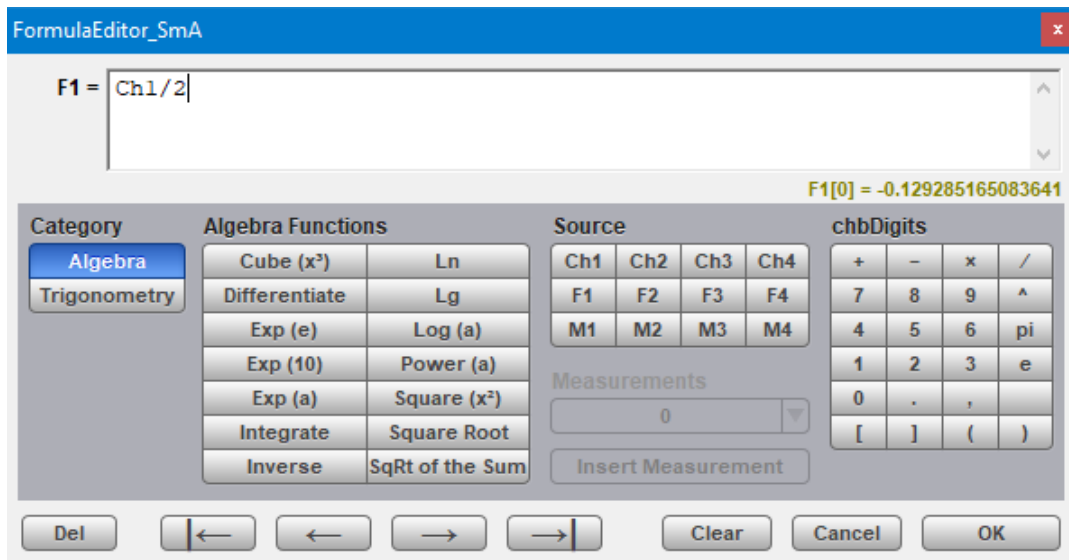

Formula Editor with algebraic functions

The formula editor above shows the algebraic functions that are displayed by default. Click **Trigonometry** to display the trigonometric functions:

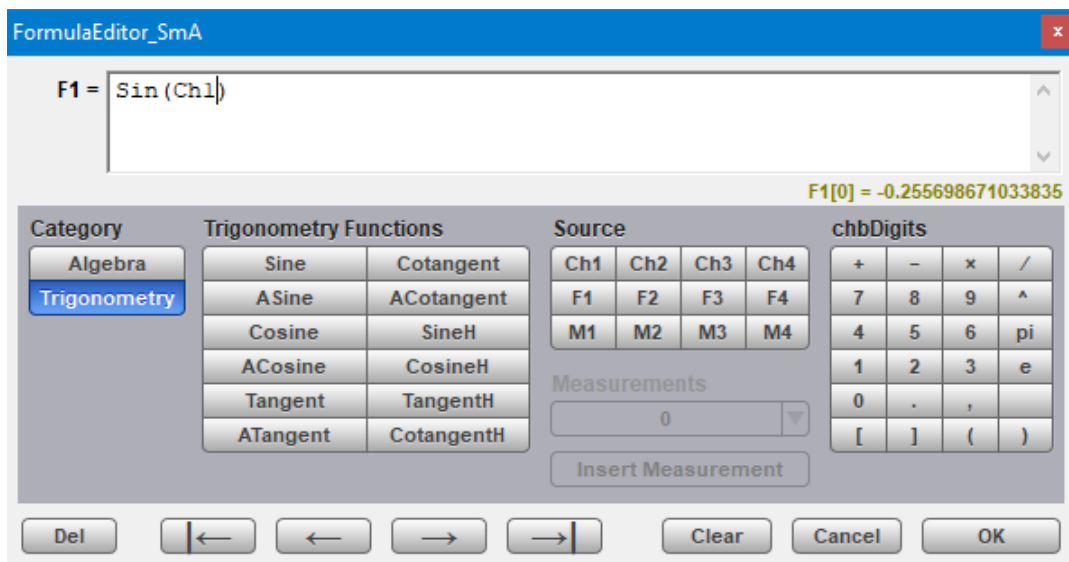

Formula Editor with trigonometric functions

7.8.1.6 Operand 1 - 4



The instrument performs math functions on the source(s) (operands) you select. The math operator is performed either on operand 1, or on operand 1 and operand 2, or on operands 1 to 4. The number of operands used depends on the math operator you select. For example, **Add** requires two operands while **Invert** requires only one operand.

The **Operand 1 to 4** controls let you select from channels, functions, waveform memories or constants.

You should be aware of some conditions of the math function menu:

- If the operand waveforms have different record lengths, the function uses the shortest record length. The instrument finds the nearest point in the longer waveform record that corresponds to the current point in the shorter record. It then performs math functions on those points and skips non-corresponding points in the longer record.
- If two operands have the same timebase scale, the resulting function has the same timebase scale, which results in the proper time scale for the function.
- If two operands have different horizontal scale settings (possibly when using a waveform memory as a operand) the resulting function has the same horizontal scale as operand 1.
- Constant operands have the same time scale as the associated waveform operand.
- You can use each function as an operand for another function. This allows you to construct equations with a large number of operators and operands.

If you select a math operator that uses more than one operand, select source 2 from the **Operand 2** drop down list box. When the **Constant** option is selected in the **Operand 2** drop-down list box the **Constant** variable becomes active. You can use the **Constant** variable to control the value of operand 2 from –100 million to 100 million.

7.8.2 Scaling

The **Scaling** menu lets you control vertical magnification and positioning without affecting the channels and timebase scaling controls.

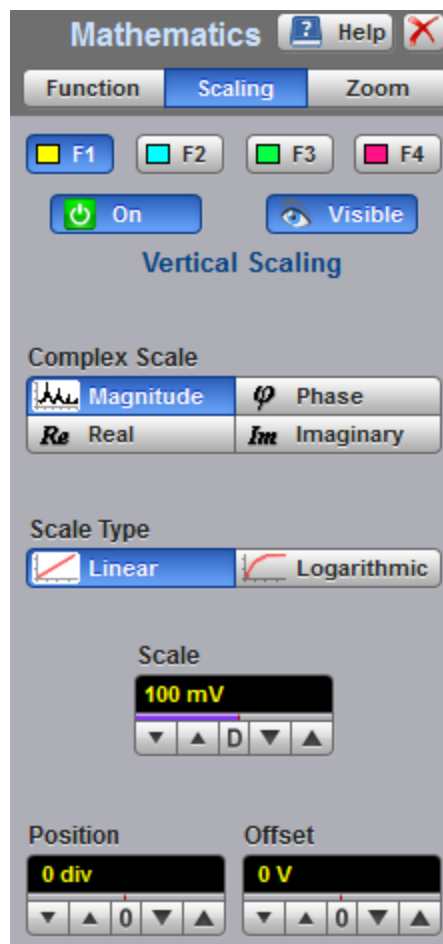

The Scaling menu for complex waveforms

7.8.2.1 Complex Scale

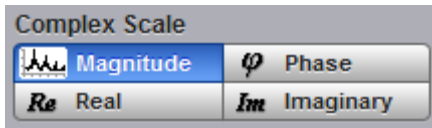

The **Complex Scale** menu selects the display format of a waveform that has a complex value. The options are:

- **Magnitude.**
- **Phase.**
- **Real.**
- **Imaginary.**

Magnitude

The peak signal amplitude is represented on a linear or logarithmic scale, in the same units as the input signal. You can choose to display data in dB or linear mode. You may display the real or imaginary parts of the spectral magnitude only. The **Vertical Position** control gives complete control over the vertical position of the spectrum.

Phase

Phase is measured with respect to a cosine whose maximum occurs at the left-hand edge of the screen, at which point it is 0°. Similarly, a positive-going sine wave starting at the left-hand edge of the screen has a -90° phase. You can display phase data as a function of frequency in degrees. You can zero the noise phase for magnitudes below a threshold level.

Real

Displays the linear magnitude of the real part of the spectral magnitude only. This is useful if you process the spectrum off-line and transform it back into a time-domain trace. You could save the real spectrum into a waveform memory.

Imaginary

Displays the linear magnitude of the imaginary part of the spectral magnitude only. This is useful if you process the spectrum off-line and transform it back into a time-domain trace. You could save the imaginary spectrum into a waveform memory.

7.8.2.2 Scale Type



The **Scale Type** menu allows you to set the scale of the vertical display. Vertical units can be either linear or logarithmic.

- **Linear** Sets the display to the current source value. Usually this is volts, but it may also be watts or amperes.
- **Logarithmic** Sets the display of the results to dB. Use the **Vertical Position** to set what vertical position in the magnitude spectrum will be zero dB.

The following equation applies:

$$dB = 20 \log_{10} \left(\frac{|X|}{X_{ref}} \right)$$

where: X is a complex data point in the spectrum, and X_{ref} is the reference value equal to 1 V.

7.8.3 Zoom

The **Zoom** menu allows you to select one from four zoom areas, and to zoom and position any of the selected zoom areas horizontally or vertically.

For more details see [Zoom Menu](#).

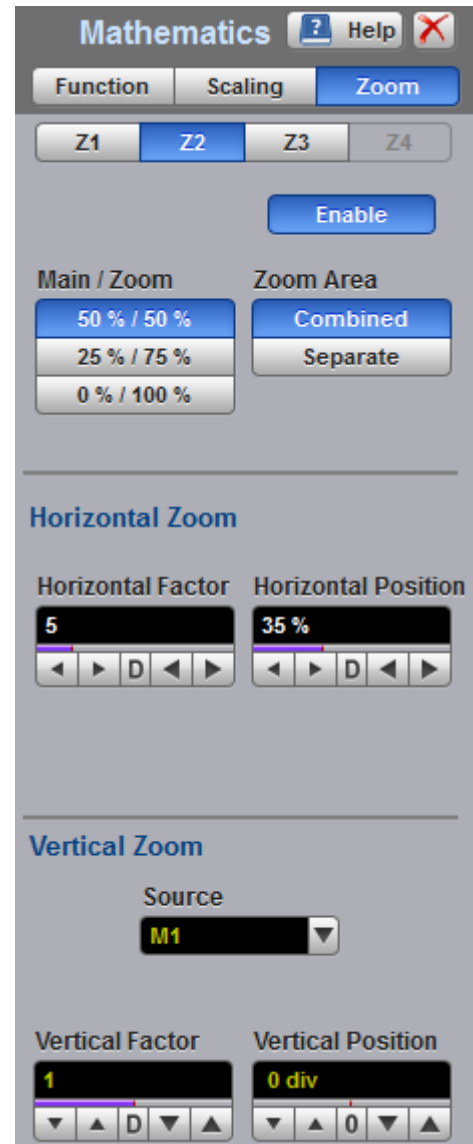

The Zoom Menu

7.9 Measure Menu



With automatic measurements, you just press a few buttons and the sampling oscilloscope does the calculations for you. Because these measurements use the waveform record points directly, they are more accurate than markers or graticules.

Measurements cover voltage, timing, and FFT. Amplitude measurements are made on vertical parameters, typically voltage. They include such parameters as **Maximum**, **Peak-Peak** and **Middle**. Timing measurements are made on horizontal parameters, typically seconds or hertz. They include such parameters as **Period**, **Width** and **Rise Time**. FFT measurements are made on both vertical and horizontal parameters, typically volts and hertz. They include such parameters as **FFT Magnitude** and **FFT Frequency**. Measurements made on two channels can include amplitude and timing parameters.

Measure

Parameter
Definition
Limit Test

Display

Off

Parameters

Statistics

Mode

Repetitive

Single-Shot

Single

Source: **Ch1**

Trace-to-trace Measurements

X Parameters

<input type="checkbox"/> Period	<input type="checkbox"/> Neg Cross
<input type="checkbox"/> Frequency	<input type="checkbox"/> Burst Width
<input type="checkbox"/> Pos Width	<input type="checkbox"/> Cycles
<input type="checkbox"/> Neg Width	<input type="checkbox"/> Time@Max
<input type="checkbox"/> Rise Time	<input type="checkbox"/> Time@Min
<input type="checkbox"/> Fall Time	<input type="checkbox"/> Pos Jitter pp
<input type="checkbox"/> Pos DCycle	<input type="checkbox"/> Pos Jitter rm
<input type="checkbox"/> Neg DCycle	<input type="checkbox"/> Neg Jitter pp
<input type="checkbox"/> Pos Cross	<input type="checkbox"/> Neg Jitter rm

Y Parameters

<input type="checkbox"/> Maximum	<input type="checkbox"/> dc RMS
<input type="checkbox"/> Minimum	<input type="checkbox"/> Cycle dc RMS
<input type="checkbox"/> Top	<input type="checkbox"/> ac RMS
<input type="checkbox"/> Base	<input type="checkbox"/> Cycle ac RMS
<input type="checkbox"/> Peak-Peak	<input type="checkbox"/> Pos Oversho
<input type="checkbox"/> Amplitude	<input type="checkbox"/> Neg Oversho
<input type="checkbox"/> Middle	<input type="checkbox"/> Area
<input type="checkbox"/> Mean	<input type="checkbox"/> Cycle Area
<input type="checkbox"/> Cycle Mean	

View Defined Parameters

Clear All Measurements

Frequency Meter Parameter

Frequency Period

Measure

Parameter
Definition
Limit Test

Display

Off

Parameters

Statistics

Mode

Repetitive

Single-Shot

Single

Source: **Ch1**

Trace-to-trace Measurements

Source 2: **Ch1**

Delay Parameters

<input type="checkbox"/> Delay 1R-1R	<input type="checkbox"/> Delay 1R-1F
<input type="checkbox"/> Delay 1F-1R	<input type="checkbox"/> Delay 1F-1F
<input type="checkbox"/> Delay 1R-nR	<input type="checkbox"/> Delay 1R-nF
<input type="checkbox"/> Delay 1F-nR	<input type="checkbox"/> Delay 1F-nF

Phase Parameters

<input type="checkbox"/> Phase Degree	<input type="checkbox"/> Phase Radian
<input type="checkbox"/> Phase %	

Gain Parameters

<input type="checkbox"/> Gain	<input type="checkbox"/> Gain dB
-------------------------------	----------------------------------

View Defined Parameters

Clear All Measurements

Frequency Meter Parameter

Frequency Period



The Measure Menu

Each measurement relates to the source that was active when you selected that measurement. It remains displayed until you remove it. If you turn off the source that was selected for a measurement, only the last measured result will be displayed.

The PicoScope 9400 makes measurements after every trigger event, always maintaining continuity between the measurement results and the display. This makes sure that no aberration in the waveform under observation is missed.

You can set measurement markers (thresholds and margins) on the display as defined parameters to track the measurement results. This helps you verify that the oscilloscope is measuring the correct phenomena and to aid in windowing the waveform properly for measurement.

Measurement Results

The measurement readouts appear in the [Measurement Area](#) of the screen. These values are displayed on tabs. The readouts are continuously updated as the oscilloscope acquires new data or as you change settings. You can display as many as ten measurements of parameters, continuously updated, and as many as four statistics measurements at any one time.

Parameter	Value
Period (Ch1)	30.03 ns
Frequency (Ch1)	33.3 MHz
Pos Width (Ch1)	15 ns
Rise Time (Ch1)	6.163 ns
Fall Time (Ch1)	6.133 ns
Maximum (Ch1)	305.4 mV
Minimum (Ch1)	-305.4 mV
Amplitude (Ch1)	600 mV
Middle (Ch1)	6.226 μ V
Mean (Ch1)	-177.7 μ V

Measure tab with the results of ten automated parameter measurements

Parameter	Current	Total Wfms	Minimum	Maximum	Mean	Std Deviation
Period (Ch1)	30.03 ns	8	30.01 ns	30.06 ns	29.28 ns	0 s
Frequency (Ch1)	33.3 MHz	8	33.27 MHz	33.32 MHz	36.17 MHz	0 Hz
Pos Width (Ch1)	15 ns	8	14.88 ns	15.16 ns	17.32 ns	0 s
Rise Time (Ch1)	6.163 ns	8	6.005 ns	6.245 ns	3.551 ns	0 s
Fall Time (Ch1)	6.133 ns	8	6.006 ns	6.255 ns	6.278 ns	0 s
Maximum (Ch1)	305.4 mV	8	302 mV	307.8 mV	408.6 mV	0 V
Minimum (Ch1)	-305.4 mV	8	-307.9 mV	-302.2 mV	-260.5 mV	0 V
Amplitude (Ch1)	600 mV	8	590.6 mV	600 mV	596.5 mV	34.09 mV
Middle (Ch1)	6.226 μ V	8	-2.296 mV	1.995 mV	-10.99 mV	0 V
Mean (Ch1)	-177.7 μ V	8	-349.7 μ V	-30.8 μ V	-412.1 μ V	506.1 μ V

Measure tab with the results of ten statistic measurements

When the instrument cannot make the requested measurement, an "Undefined" error message is displayed instead of measurement results. Usually, this is because there are not enough sample points, there is no edge on the display, or the specified channel is turned off.

7.9.1 Parameter

Parameter

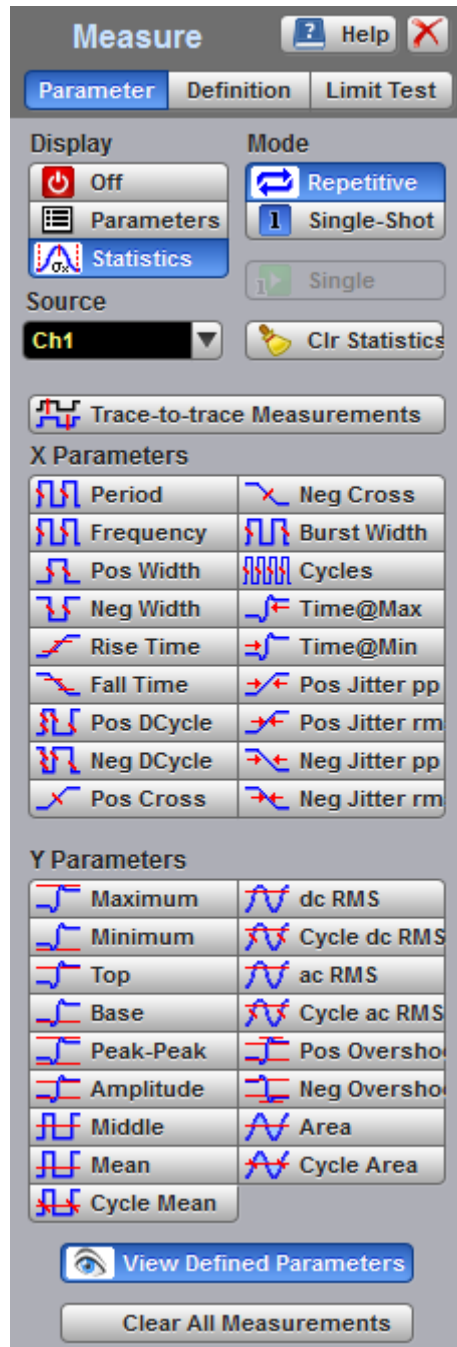

The Parameter Menu

7.9.1.1 Display

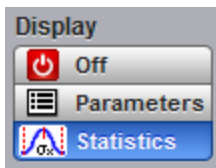

Two types of measurements are used in the PicoScope 9400 Series:

- Measurements of parameters (**Parameters**).
- Statistics measurements (**Statistics**).

Click on the option for the type of measurement that you require. **Off** removes measurement results, annotations and markers from the display.

Statistics

The **Statistics** function calculates the minimum, maximum, mean and standard deviation of the automatic measurement results. The current value and amount of measurements are also displayed.

When you turn **Statistics** on, the minimum, maximum, mean and standard deviation values start to accumulate at the same time. All results are continuously updated; the mean, standard deviation results are also calculated and continuously updated. Minimum and maximum are the absolute extremes of the automatic measurements. Mean and standard deviation calculate the mean and standard deviation of the automatic measurement results. Mean is the statistical average of all results for a particular measurement. Standard deviation measures the dispersion of those measurement results.

The figure below shows the mean and standard deviation more graphically. Standard deviation is represented by the Greek letter sigma (σ). For a Gaussian distribution, two sigma ($\pm 1\sigma$ from the mean) is where 68.3% of the data points reside. Four sigma ($\pm 2\sigma$ from the mean) is where 95.4% of the data points reside. Six sigma ($\pm 3\sigma$ from the mean) is where 99.7% of the data points reside.

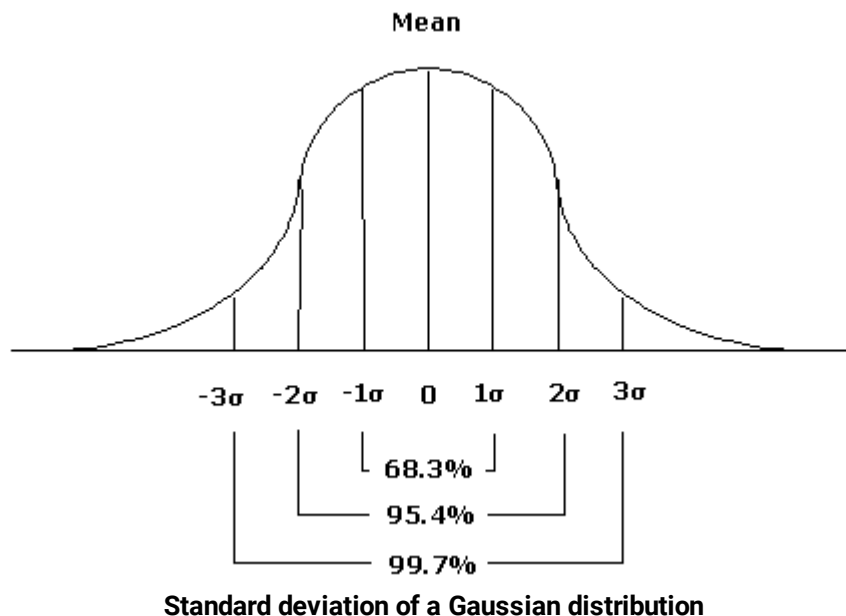

The mean is calculated as follows:

$$\mu = \frac{\sum_{i=1}^n X_i}{n},$$

where: μ - mean, n - the number of measurements taken, X_i - measurement i -th result.

The standard deviation is calculated as follows:

$$\sigma = \sqrt{\frac{\sum_{i=1}^n (X_i - \bar{X})^2}{n-1}},$$

where: σ - standard deviation, n - the number of measurements taken, X_i - measurement i -th result, \bar{X} - the mean.

Click the **Definition** and use the **Statistics** menu for some statistics options.

7.9.1.2 Source

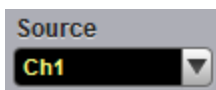

The **Source** drop-down list box selects the source you are measuring.

You can select as the source:

- Channel 1 through 4.
- Functions 1 through 4.
- Waveform memories 1 through 4.

The measurement readouts of each parameter will have the same color as the selected source.

7.9.1.3 Mode

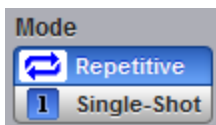

Two modes are available for extracting parameters:

- **Repetitive.** This mode dynamically extracts the same number of parameters, based on successive acquisition sequences, and updates the measurements approximately every 100 ms (except at very slow repetition rates).
- **Single-shot.** Extracts up to ten parameters, based on the last acquisition, and displays the result.

7.9.1.4 Single



Clicking the **Single** button provides single-shot measurement of selected parameters.

7.9.2 X Parameters...

The **X Parameters** are eighteen timing parameters used for pulse measurements. Once the **Top** and **Base** calculation is completed (according to the [Method](#) setting), most of the timing and amplitude measurements can be made.

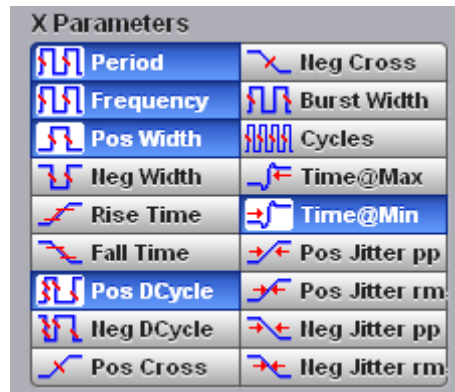

You can continuously update as many as ten parameter measurements, and as many as ten statistics measurements, at any one time.



The pulse measurement algorithms for **X Parameters** will only work when a single-valued signal is used, and no NRZ eye diagram or RZ eye diagram is present on the screen. Measurements made on both NRZ and RZ eye diagrams will fail.



Period

Period is a measure of the time between the mid-threshold crossings of two consecutive edges of the same polarity. The PicoScope 9400 starts the measurement on the first edge on the leftmost portion of the measurement region (left margin) and stops the measurement on the last edge on the rightmost portion of the measurement region (right margin).

Because the detected edges can be either rising or falling, the period is determined as follows:

$$\text{Period} = T_{\text{cross}3} - T_{\text{cross}1}$$

where $T_{\text{cross}3}$ and $T_{\text{cross}1}$ are the times of the first two consecutive crossings on the same slope at the mid-reference level.

If more than one period can be found within the margins, the scope measures the average period.



Frequency

Frequency is defined as the inverse of the period ($1/\text{period}$). Period is a measure of the time between the mid-threshold crossings of two consecutive edges of the same polarity. The PicoScope 9400 starts the measurement on the first edge on the leftmost portion of the measurement region (left margin) and stops the measurement on the last edge on the rightmost portion of the measurement region (right margin).

Because the detected edges can be either rising or falling, the frequency is determined as follows:

$$\text{Frequency} = 1/\text{Period} = 1/(T_{\text{cross}3} - T_{\text{cross}1})$$

where $T_{\text{cross}3}$ and $T_{\text{cross}1}$ are the times of the first two consecutive crossings on the same slope at the mid-reference level.

If more than one period can be found within the margins, the scope measures the average frequency value.



Pos Width

Pos Width

Pos Width (Positive Pulse Width) is a measure of the time from the mid-threshold of the first rising edge to the mid-threshold of the next falling edge. The PicoScope 9400 starts the measurement on the first edge on the leftmost portion of the measurement region (left margin) and stops the measurement on the last edge on the rightmost portion of the measurement region (right margin).

Positive pulse width is determined as follows:

$$\text{Positive Width} = T_{\text{cross}2} - T_{\text{cross}1}$$

where $T_{\text{cross}1}$ and $T_{\text{cross}2}$ are the two consecutive horizontal crossings on the first positive pulse.

If more than one positive pulse width can be found within the margins, the scope measures the average value of the positive pulse width.



Neg Width

Neg Width

Neg Width (Negative Pulse Width) is a measure of the time from the mid-threshold of the first falling edge to the mid-threshold of the next rising edge. The PicoScope 9400 starts the measurement on the first edge on the leftmost portion of the measurement region (left margin) and stops the measurement on the last edge on the rightmost portion of the measurement region (right margin).

Negative pulse width is determined as follows:

$$\text{Negative Width} = T_{\text{cross}2} - T_{\text{cross}1}$$

where $T_{\text{cross}1}$ and $T_{\text{cross}2}$ are the two consecutive horizontal crossings on the first negative pulse.

If more than one negative pulse width can be found within the margins, the scope measures the average value of the negative pulse width.

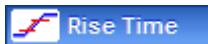

Rise Time

Rise Time

Rise Time is a measure of the time at the upper threshold minus the time at the lower threshold on the edge you are measuring on. It is a measure of the transition time of the data on the positive (rising) edge of a waveform. The PicoScope 9400 starts the measurement on the first edge on the leftmost portion of the measurement region (left margin) and stops the measurement on the last edge on the rightmost portion of the measurement region (right margin).

Rise Time is determined as follows:

$$\text{Rise Time} = T_{\text{cross}(\text{Upper Threshold})} - T_{\text{cross}(\text{Lower Threshold})}$$

where $T_{\text{cross}(\text{Upper Threshold})}$ is the time of crossing with the upper threshold, and $T_{\text{cross}(\text{Lower Threshold})}$ is the time of crossing with the lower threshold.

If more than one rise time can be found within the margins, the scope measures the average value of rise time.

The rise time will not be measured until the rising edge completes the transition through all three levels.

 **Fall Time**

Fall Time is a measure of the time at the lower threshold minus the time at the upper threshold on the edge you are measuring on. It is a measure of the transition time of the data on the negative (falling) edge of a waveform. The PicoScope 9400 starts the measurement on the first edge on the leftmost portion of the measurement region (left margin) and stops the measurement on the last edge on the rightmost portion of the measurement region (right margin).

Fall Time is determined as follows:

$$\text{Fall Time} = T_{\text{cross(Lower Threshold)}} - T_{\text{cross(Upper Threshold)}}$$

where $T_{\text{cross(Lower Threshold)}}$ is the time of crossing with the lower threshold, and $T_{\text{cross(Upper Threshold)}}$ is the time of crossing with the upper threshold

If more than one fall time can be found within the margins, the scope measures the average value of rise time.

The fall time will not be measured until the falling edge completes the transition through all three levels.

 **Positive Duty Cycle**

Positive Duty Cycle is defined as the ratio of the positive pulse width to the period. This is the percentage of the period that the positive pulse width occupies. The PicoScope 9400 starts the measurement on the first edge on the leftmost portion of the measurement region (left margin) and stops the measurement on the last edge on the rightmost portion of the measurement region (right margin).

Positive Duty Cycle is determined as follows:

$$\text{Positive Duty Cycle} = (\text{Positive Width} / \text{Period}) \times (100\%)$$

If more than one positive duty cycle can be found within the margins, the scope measures the average value of all positive duty cycles.

The positive duty cycle will not be measured until the period and positive pulse width complete the transition through all three levels.

 **Negative Duty Cycle**

Negative Duty Cycle is defined as the ratio of the negative pulse width to the period. This is the percentage of the period that the negative pulse width occupies. The PicoScope 9400 starts the measurement on the first edge on the leftmost portion of the measurement region (left margin) and stops the measurement on the last edge on the rightmost portion of the measurement region (right margin).

Negative Duty Cycle is determined as follows:

$$\text{Negative Duty Cycle} = (\text{Negative Width} / \text{Period}) \times (100\%)$$

If more than one negative duty cycle can be found within the margins, the scope measures the average value of all negative duty cycles.

The negative duty cycle will not be measured until the period and negative pulse width completes the transition through all three levels.

 **Positive Crossing**

Positive Crossing is defined as the time of the first positive crossing of the data sampled at the mid-reference level in the measurement region. The PicoScope 9400 starts the measurement on the first leftmost portion of the measurement region (left margin) and stops the measurement on the rightmost portion of the display (right margin).

Positive crossing is determined as follows:

$$\text{Positive Crossing} = T_{\text{cross}}$$

where T_{cross} is the horizontal coordinate of the first positive crossing.

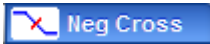

Neg Cross

Negative Crossing

Negative Crossing is defined as the time of the first negative crossing of the data sampled at the mid-reference level in the measurement region. The PicoScope 9400 starts the measurement on the first leftmost portion of the measurement region (left margin) and stops the measurement on the last edge on the rightmost portion of the display (right margin).

Negative crossing is determined as follows:

$$\text{Negative Crossing} = T_{\text{cross}}$$

where T_{cross} is the horizontal coordinate of the first negative crossing.

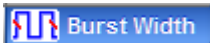

Burst Width

Burst Width

Burst Width is defined as the time between the first and last crossings, either positive or negative, of the waveform at the mid-reference level in the measurement region. The PicoScope 9400 starts the measurement on the first leftmost portion of the measurement region (left margin) and stops the measurement on the last edge on the rightmost portion of the display (right margin).

Burst width is determined as follows:

$$\text{Positive Width} = T_{\text{crossL}} - T_{\text{crossF}}$$

where T_{crossL} is the horizontal coordinate of the last crossing, and T_{crossF} is the horizontal coordinate of the first crossing.

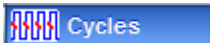

Cycles

Cycles

Cycles is defined as the number of cycles of a periodic waveform between the mid-threshold crossings of two consecutive first and last edges of the same polarity. The PicoScope 9400 starts the measurement on the first edge on the leftmost portion of the measurement region (left margin) and stops the measurement on the last edge on the rightmost portion of the measurement region (right margin). The detected edges can be either rising or falling.

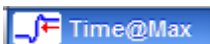

Time@Max

Time@Maximum

Time@Maximum is a measure of the time of the first occurrence of the first data sample with the maximum signal level. The PicoScope 9400 starts the measurement on the first leftmost portion of the measurement region (left margin) and stops the measurement on the last edge on the rightmost portion of the display (right margin).

The **Time@Maximum** is position-independent. Therefore, the instrument uses the entire waveform on the display graticule to determine the maximum signal level.

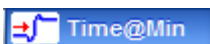

Time@Min

Time@Minimum

Time@Minimum is a measure of the time of the first occurrence of the first data sample with the minimum signal level. The PicoScope 9400 starts the measurement on the first leftmost portion of the measurement region (left margin) and stops the measurement on the last edge on the rightmost portion of the display (right margin).

Time@Minimum is position-independent. Therefore, the instrument uses the entire waveform on the display graticule to determine the minimum signal level.

Pos Jitter pp **Positive Jitter p-p**

Positive Jitter p-p is a measure of peak-peak time variations of the rising edges of a pulse waveform at the middle threshold.

Positive Jitter p-p is determined as follows:

$$\text{Positive Jitter p-p} = \text{Full width of the Horizontal Histogram in the Middle Threshold}$$

Pos Jitter rm **Positive Jitter RMS**

Positive Jitter RMS is a measure of RMS time variations of the rising edges of a pulse waveform at the middle threshold.

The **Positive Jitter RMS** is determined as follows:

$$\text{Positive Jitter RMS} = 1\sigma \text{ (standard deviation) of the Horizontal Histogram in the Middle Threshold}$$

Neg Jitter pp **Negative Jitter p-p**

Negative Jitter p-p is a measure of the peak-peak time variations of the falling edges of a pulse waveform at the middle threshold.

The **Negative Jitter p-p** is determined as follows:

$$\text{Negative Jitter p-p} = \text{Full width of the Horizontal Histogram at the Middle Threshold}$$

Neg Jitter rm **Negative Jitter RMS**

Negative Jitter RMS is a measure of the RMS time variations of the falling edges of a pulse waveform at the middle threshold.

Negative Jitter RMS is determined as follows:

$$\text{Negative Jitter RMS} = 1\sigma \text{ (standard deviation) of the Horizontal Histogram at the Middle Threshold}$$

7.9.3 Y Parameters...

The **Y Parameters** menu is a list of amplitude parameters. This list includes seventeen amplitude parameters used for pulse measurements. Once the **Top** and **Base** calculation is completed (according to the [Method](#) setting), most of the timing and amplitude measurements can be made.

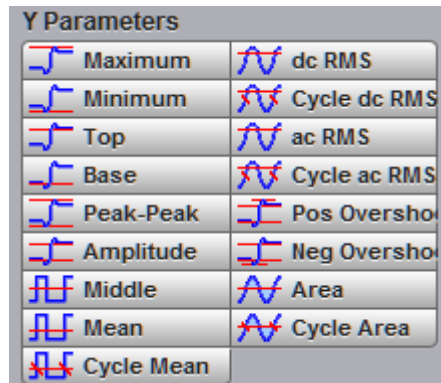

You can continuously update as many as ten measurement parameters, and as many as four statistics measurements at any one time.



The pulse measurement algorithms for **Y Parameters** will only work when a single-valued signal is used, and no NRZ eye diagram or RZ eye diagram is present on the screen. Measurements made on both NRZ and RZ eye diagrams will fail.

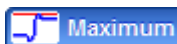

Maximum

Maximum is the voltage (or power) of the absolute maximum level of the measurement region. The maximum level is taken directly from the histogram data. The PicoScope 9400 Series starts the measurement on the first leftmost portion of the measurement region (left margin) and stops the measurement on the rightmost portion of the display (right margin).



Minimum

Minimum is the voltage (or power) of the absolute minimum level of the measurement region. The minimum level is taken directly from the histogram data. The PicoScope 9400 Series starts the measurement on the first leftmost portion of the measurement region (left margin) and stops the measurement on the rightmost portion of the display (right margin).



Top

Top is the voltage of the statistical maximum level. Use the [Method](#) and [Thresholds](#) menus to customize the measurement threshold levels. **Top** may be equal to **Maximum** for many waveforms, such as triangle waveforms. The PicoScope 9400 Series starts the measurement on the first leftmost portion of the measurement region (left margin) and stops the measurement on the rightmost portion of the display (right margin).



Base

Base is the voltage of the statistical minimum level. Use the [Method](#) and [Thresholds](#) menus to customize the measurement threshold levels. **Base** may be equal to **Minimum** for many waveforms, such as triangle waveforms. The PicoScope 9400 Series starts the measurement on the first leftmost portion of the measurement region (left margin) and stops the measurement on the rightmost portion of the display (right margin).

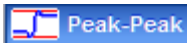

Peak-Peak

Peak-Peak

Peak-Peak is a measure of the difference between **Maximum** and **Minimum** of a displayed waveform. The PicoScope 9400 Series starts the measurement on the first leftmost portion of the measurement region (left margin) and stops the measurement on the rightmost portion of the display (right margin).

Peak-Peak is determined as follows:

$$\text{Peak-Peak} = \text{Maximum} - \text{Minimum}$$

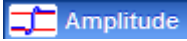

Amplitude

Amplitude

Amplitude is a measure of the difference between the **Top** and **Base** of a displayed pulse waveform. Use the [Method](#) and [Thresholds](#) menus to customize the measurement threshold levels. **Amplitude** may be equal to **Peak-Peak** for many waveforms, such as triangle waveforms. The PicoScope 9400 Series starts the measurement on the first leftmost portion of the measurement region (left margin) and stops the measurement on the rightmost portion of the display (right margin).

Amplitude is determined as follows:

$$\text{Amplitude} = \text{Top} - \text{Base}$$

where *Top* is the statistical maximum level, and *Base* is the statistical minimum level.



Top value may be less than or equal to the maximum value of the waveform, while **Base** value may be greater than or equal to the minimum value of the waveform.



Middle

Middle

Middle is the computation of the middle point between the maximum and minimum amplitude peaks of the waveform over the measurement region. The PicoScope 9400 Series starts the measurement on the first leftmost portion of the measurement region (left margin) and stops the measurement on the rightmost portion of the display (right margin).

Middle is determined as follows:

$$\text{Middle} = (\text{Maximum} - \text{Minimum}) / 2$$

where *Maximum* is the voltage (or power) of the absolute maximum value of the waveform, and *Minimum* the voltage (or power) of the absolute minimum value of the waveform.



Mean

Mean

Mean is the average mean of all the waveform data over the measurement region. The PicoScope 9400 Series starts the measurement on the first leftmost portion of the measurement region (left margin) and stops the measurement on the rightmost portion of the display (right margin).

Mean is determined as follows:

$$\text{Mean} = \frac{1}{n} \sum_{i=1}^N V(i)$$

where *n* is the number of waveform points on screen and not the memory depth, *V(i)* is the voltage at the *i*-th point on screen.

 **Cycle Mean**

Cycle Mean is the averaged mean of all the waveform data of one cycle of the signal over the measurement region. The average of the data values is taken of an integral number of periods. The PicoScope 9400 Series starts the measurement on the first leftmost portion of the measurement region (left margin) and stops the measurement on the rightmost portion of the display (right margin). See also **Mean**.



You can customize this measurement to be made either on one waveform cycle or across all data on the display. The [Margins](#) menu sets the margin markers to show where the scope is making the automatic measurement. All calculations of the **Cycle Mean** value will be performed only inside these margins.

 **DC RMS**

DC RMS is the root-mean-square voltage of the waveform over the measurement region. The PicoScope 9400 Series starts the measurement on the first leftmost portion of the measurement region (left margin) and stops the measurement on the rightmost portion of the display (right margin). The instrument can make either AC or DC RMS measurements.

The **DC RMS** measurement is determined as follows:

$$dcRMS = \sqrt{\frac{\sum_{i=1}^N [V(i)]^2}{n}}$$

where: n is the number of waveform points on screen and not the memory depth, and $V(i)$ is the voltage at the i -th point on screen.

 **Cycle DC RMS**

Cycle DC RMS is the averaged root-mean-square voltage of one cycle of the waveform value over the measurement region. The average of the data values is taken over an integral number of periods. The PicoScope 9400 Series starts the measurement on the first leftmost portion of the measurement region (left margin) and stops the measurement on the rightmost portion of the display (right margin). The instrument can make either cycle AC or DC RMS measurements. See also **DC RMS**.



You can customize this measurement to be made either on one waveform cycle or across all data on the display. The [Margins](#) menu sets the margin markers to show where the scope is making the automatic measurement. All calculations of the Cycle DC RMS value will be performed only inside these margins.



ac RMS

AC RMS

AC RMS is the root-mean-square voltage of the waveform less the mean value over the measurement region. The PicoScope 9400 Series starts the measurement on the first leftmost portion of the measurement region (left margin) and stops the measurement on the rightmost portion of the display (right margin). The instrument can make either AC or DC RMS measurements.

The **AC RMS** measurement is determined as follows:

$$acRMS = \sqrt{\frac{\sum_{i=1}^N [V(i) - Mean]^2}{n}}$$

where: n is the number of waveform points on screen and not the memory depth, $V(i)$ is the voltage at the i -th point on screen, and $Mean$ is an average mean voltage.



Cycle ac RMS

Cycle AC RMS

Cycle AC RMS is the averaged root-mean-square voltage of one cycle of the waveform less the cycle mean value over the measurement region. The average of the data values is taken over an integral number of periods. The PicoScope 9400 Series starts the measurement on the first leftmost portion of the measurement region (left margin) and stops the measurement on the rightmost portion of the display (right margin). The instrument can make either AC or DC RMS measurements. See also **AC RMS**.



You can customize this measurement to be made either on one waveform cycle or across all data on the display. The [Margins](#) menu sets the margin markers to show where the scope is making the automatic measurement. All calculations of the **Cycle AC RMS** value will be performed only inside these margins.

Positive Overshoot

Positive Overshoot is defined as the maximum distortion that follows a positive waveform edge transition. This distortion occurs after the edge crosses through the waveform threshold levels. The PicoScope 9400 Series starts the measurement on the first leftmost portion of the measurement region (left margin) and stops the measurement on the rightmost portion of the display (right margin). The instrument can make both positive and negative overshoot measurements.

Positive Overshoot is determined when the waveform edge is rising (upward slope), and is computed as follows:

$$\text{Positive Overshoot} = [(Maximum - Top) / Amplitude] \times 100\%$$

where: *Maximum* is the signal maximum, *Top* is the signal top value, and *Amplitude* is the signal amplitude.

Negative Overshoot

Negative Overshoot is defined as the maximum distortion that follows a negative waveform edge transition. This distortion occurs after the edge crosses through the waveform threshold levels. The PicoScope 9400 Series starts the measurement on the first leftmost portion of the measurement region (left margin) and stops the measurement on the rightmost portion of the display (right margin). The instrument can make both positive and negative overshoot measurements.

Negative Overshoot, determined when the waveform edge is falling, is computed as follows:

$$\text{Negative Overshoot} = [(Base - Minimum) / Amplitude] \times 100\%$$

where: *Minimum* is the signal minimum, *Base* is the signal base value, and *Amplitude* is the signal amplitude.

Area

Area is the area under the curve of the waveform within the measurement region in vertical units multiplied by horizontal units, such as volt-seconds or watt-seconds. Area measured above ground is positive; area measured below ground is negative.

Area is determined as follows:

$$\text{Area} = \int_{\text{Start}}^{\text{End}} \text{Waveform}(t) dt$$

In practice the PicoScope 9400 Series uses the following algorithm:

$$\text{Area} = \frac{\Delta t}{N} \sum_{i=1}^N V(i)$$

where: *N* is the number of waveform points on screen and not the memory depth, *V(i)* is the voltage at the *i*-th point on screen, and Δt is the measured region duration.



Cycle Area

Cycle Area is the averaged area under the curve for of one cycle the waveform within the measurement region in vertical units multiplied by horizontal units, such as volt-seconds or watt-seconds. The average of the data values is taken over an integral number of periods. Area measured above ground is positive; area measured below ground is negative. See also **Area**.

7.9.4 Trace-to-trace Measurements

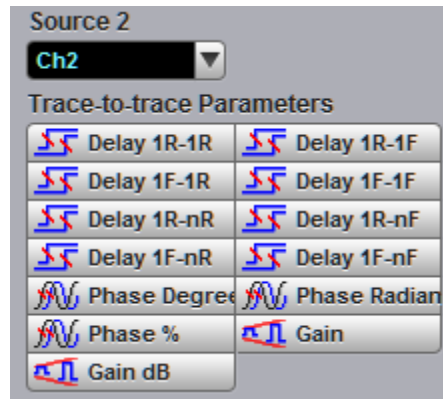

Clicking **Trace-to-trace Measurements** opens the list of parameters that can be measured with two signal sources.



You can select as one of the sources:

- Channels 1 through 4
- Functions 1 through 4
- Waveform memories 1 through 4
- Any of the spectra

The list of measurements includes eight delay parameters, three phase parameters, and two gain parameters.



You can continuously update as many as ten measurement parameters, and as many as four statistics measurements at any one time.



The pulse measurement algorithms for **X Parameters** will only work when a single-valued signal is used, and no NRZ eye diagram or RZ eye diagram is present on the screen. Measurements made on NRZ and RZ eye diagrams will fail.

7.9.4.1 Source 2

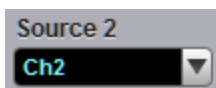

When the **Trace-to-trace Measurements** menu is selected, the **Source** drop-down list box located on the first page of the [Measure](#) menu selects the reference source, while the **Source 2** drop-down list box located on the **Trace-to-trace Measurements** menu page selects the second source.

7.9.4.2 Delay



Delay is defined as the time interval between the crossings of the two mid-reference levels on the two sources of the measurement. The PicoScope 9400 starts the measurement on the first edge on the leftmost portion of the measurement region (left margin) and stops the measurement on the last edge on the rightmost portion of the measurement region (right margin).

Delay is determined as follows:

$$\text{Delay} = T_{\text{cross}2} - T_{\text{cross}1}$$

where: $T_{\text{cross}2}$ is the horizontal crossing on the rising or falling edge of the second source, and $T_{\text{cross}1}$ is the horizontal crossing on the rising or falling edge of the first (reference) source.

The delay will not be measured until the rising and falling edges on both sources complete the transition through all three levels.

You can select one of the eight delay options:

- **Delay 1R-1R** is the delay between the first rising edge on the reference source and the first rising edge on the second source
- **Delay 1R-1F** is the delay between the first rising edge on the reference source and the first falling edge on the second source
- **Delay 1F-1R** is the delay between the first falling edge on the reference source and the first rising edge on the second source
- **Delay 1F-1F** is the delay between the first falling edge on the reference source and the first falling edge on the second source
- **Delay 1R-nR** is the delay between the first rising edge on the reference source and the last rising edge on the second source
- **Delay 1R-nF** is the delay between the first rising edge on the reference source and the last falling edge on the second source
- **Delay 1F-nR** is the delay between the first falling edge on the reference source and the last rising edge on the second source
- **Delay 1F-nF** is the delay between the first falling edge on the reference source and the last falling edge on the second source

7.9.4.3 Phase

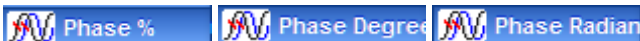

Phase is the amount by which a waveform leads or lags another in time. It is defined between the first rising edge on the reference source and the first rising edge on the second source. The PicoScope 9400 starts the measurement on the first edge on the leftmost portion of the measurement region (left margin) and stops the measurement on the last edge on the rightmost portion of the measurement region (right margin).

The **Phase** is determined as follows:

$$\text{PhaseRad} = \frac{T_{\text{cross2}} - T_{\text{cross1}}}{\text{Period}} \times 100\%$$

$$\text{PhaseRad} = \frac{T_{\text{cross2}} - T_{\text{cross1}}}{\text{Period}} \times 2\pi$$

$$\text{PhaseRad} = \frac{T_{\text{cross2}} - T_{\text{cross1}}}{\text{Period}} \times 100\%$$

where: T_{cross2} - is a horizontal crossing on the first rising edge of the second source, T_{cross1} is a horizontal crossing on the first rising edge of the first (reference) source, and Period is a period value.

You can select one of three phase options:

- **Phase Degree** is a phase expressed in degrees, where 360° constitutes one waveform cycle
- **Phase Radian** is a phase expressed in radians, where one waveform cycle (360°) corresponds to 2 radians
- **Phase %** is a phase expressed as a percentage of one waveform cycle



Both the first (reference) and the second sources should have an equal period value when the phase measurements are performed.

7.9.4.4 Gain



Gain



Gain dB

Gain is the amplitude gain between two selected waveforms. The PicoScope 9400 starts the measurement on the first edge on the leftmost portion of the measurement region (left margin) and stops the measurement on the last edge on the rightmost portion of the measurement region (right margin).

Gain is determined as follows:

$$\text{Gain} = \frac{\text{Amplitude2}}{\text{Amplitude1}}$$

$$\text{Gain}_{\text{dB}} = 20 \log_{10} \left(\frac{\text{Amplitude2}}{\text{Amplitude1}} \right)$$

where: Amplitude1 is the amplitude measurement of the first (reference) source, and Amplitude2 is the amplitude measurement of the second source.

You can select one of two gain options:

- **Gain** is a gain expressed as an amplitude gain between the amplitudes of two waveforms
- **Gain dB** is a gain expressed in decibels

7.9.5 Counter

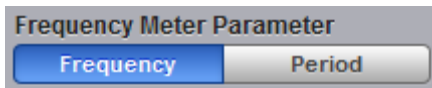

The counter provides frequency or period counter measurements on any of the input channels or the external prescaled trigger input.

With the internal trigger, the counter counts trigger level crossings within a certain amount of time (gate time) and displays the results in the trigger status area. With the external prescaled trigger, the counter counts threshold crossings on the prescaled signal within a certain amount of time (gate time) and displays the results in the same area.

The counter is asynchronous from the oscilloscope's acquisition system and is always acquiring. For frequency and period measurements, the numbers of digits softkey is not adjustable and is normally 7 digits.

7.9.6 View Define Parameters



The markers can be used to give you a visual indication of where you are manually setting the thresholds and margins. To use the markers to show the settings, click **View Defined Parameters**.

7.9.7 Clear All Measurements



Clicking **Clear All Measurements** removes all selected measurements and all measurement results. This function is useful when measurements were performed with waveforms from different sources.

7.9.8 Definition

Definition

The **Definition** menu sets the measurement points (thresholds and margins) where the automatic measurements are made. These measurement points can be set to the same points for all waveforms (channel waveforms, function waveforms, and waveform memories) or can be set differently for each individual waveform. The menu influences the measurement algorithm by allowing you to use the standard IEEE measurement points, or customize the measurements with the user-defined selections. The **Definition** menu also includes the [Statistics](#) menu for some statistics options.

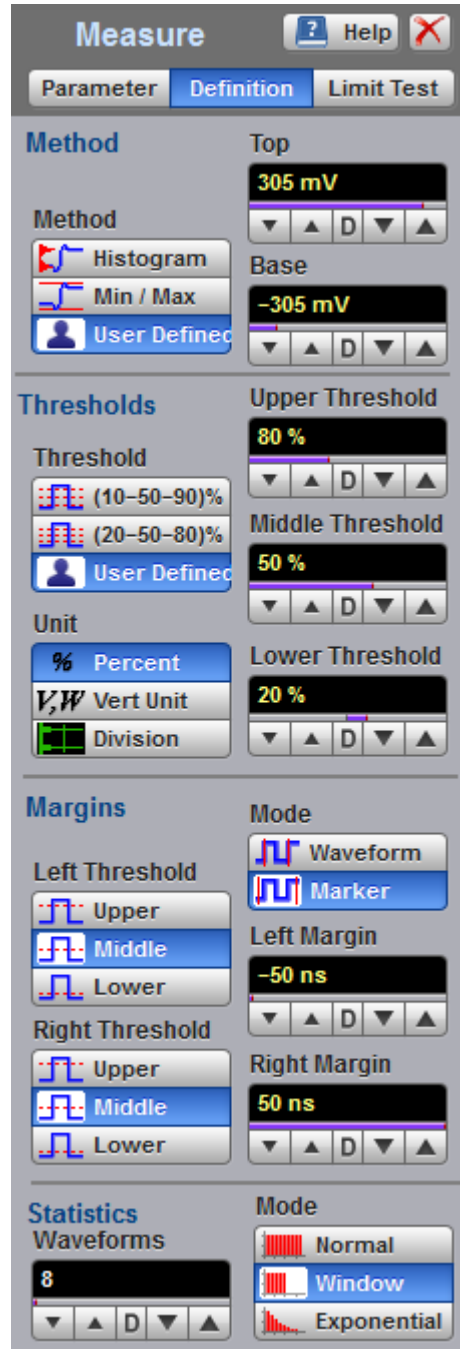

The Definition Menu

The **Definition** menu is different when you work in the time domain with signals or in the frequency domain with spectra.

Standard IEEE measurement points

The waveform drawing below shows some of the standard measurement points, thresholds, and parameters.

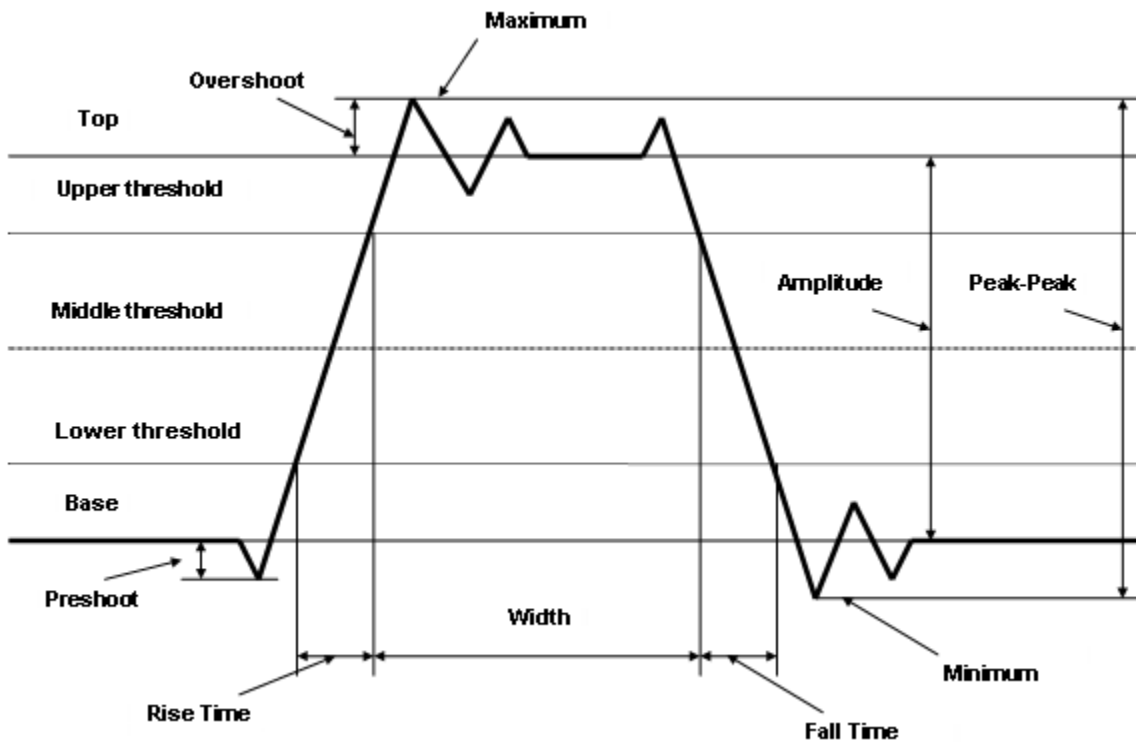

7.9.8.1 Method

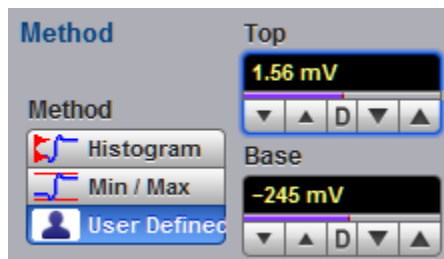

The Method Menu

7.9.8.1.1 Method

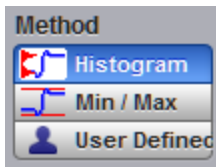

The **Method** menu sets the **Top** and **Base** vertical reference thresholds for amplitude measurements. It also sets the values from which the upper, middle and lower thresholds are calculated. The **Top** and **Base** variables are displayed when the **User Defined** method is selected. The three selections under the **Method** menu allow the user to choose the method for determining the **Top** and **Base** of the waveform.

- **Histogram.** The instrument calculates the top and base using the IEEE standards with a voltage histogram of the waveform that is on the display. The instrument finds the prevalent top and base voltage values. Make sure there is enough of the signal displayed on the screen so that the instrument can accurately determine the top and base values of the waveform. However, if too much of the top and base of the waveform are on the display, it may reduce the number of sample points on the edge of interest, which may reduce the repeatability of your measurements. A good rule of thumb is to have two divisions of top and two divisions of base.
- **Min / Max.** The absolute maximum (positive peak) of the targeted waveform is used as the **Top**, and the absolute minimum (negative peak) of the targeted waveform is used as the **Base**.
- **User Defined.** This method lets you set the top and base to a specific voltage value. The upper, middle and lower thresholds are then calculated from the voltage values you select. The **User Defined** method simplifies the threshold detection algorithm. The result is that the measurement throughput of the instrument is increased, because the instrument does not have to calculate the top and base values. After you selected the **User Defined** method, the **Top** and **Base** variables becomes active.

7.9.8.1.2 Top and Base

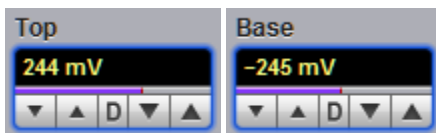

The **Top** and **Base** variables let you set the top and base to a specific voltage value. As an example, for a 200 mV/div vertical scale you can set the top and base voltage values from -798 mV to 798 mV in 25 mV (coarse) or 1.56 mV (fine) increments determined by the voltage range you are in.

Note that the top value cannot be less than the base value.

7.9.8.2 Thresholds

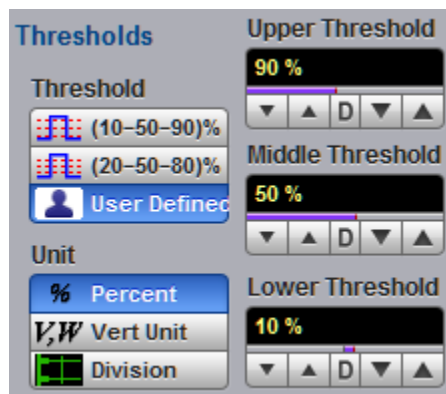

The Threshold Menu

7.9.8.2.1 Threshold

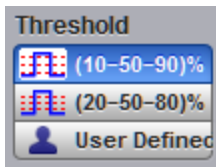

The **Threshold** menu sets the measurement points that the automatic measurements use for calculating the timing measurement results. The threshold points are upper, middle, and lower. For example, rise time is measured from the lower threshold to the upper threshold, while a width measurement is made between two middle thresholds.

The three threshold choices are the standard IEEE measurement points:

- **10%-50%-90%**
- **20%-50%-80%**
- **User Defined**

By default, the PicoScope 9400 uses the IEEE thresholds of 10%, 50% and 90% for pulse measurements. A rising or falling edge is only recognized after passing through all three thresholds. You can specify your own thresholds rather than using the IEEE standard 10%, 50% and 90% levels, but this can dramatically change the measurement results. Note how the rise and fall times will be faster for the same waveform using the 80%, 20% criteria instead of the 90%, 10% criteria. You may rely on the scope to automatically set top and base or redefine those levels yourself and use units of voltage instead of percent.

The **Upper Threshold**, **Middle Threshold**, and **Lower Threshold** variables are displayed only when the **User Defined** is selected in the **Thresholds** menu.

10%-50%-90% and 20%-50%-80%

These are two IEEE standard pulse measurement thresholds for all measurements. These standard thresholds are calculated as a percentage of the top-base values, and the top-base values are calculated from the waveform that is on the display.

10%-50%-90% means: Lower threshold = 10 %, Middle threshold = 50 %, Upper threshold = 90 %.

20%-50%-80% means: Lower threshold = 20 %, Middle threshold = 50 %, Upper threshold = 80 %.

Make sure that the waveform is expanded vertically and horizontally so that the instrument can accurately determine the top and base values of the waveform. However, if too much of the top and base of the waveform is on the display, it may reduce the repeatability of your measurements. A good rule of thumb is to have two divisions of top and two divisions of base.

User Defined

For waveform records or portions of waveform records on which you want to make custom measurements or define thresholds in units of volts, percents or divisions, you can use the **User Defined** setting. By using units of volts, you can fix the thresholds and compare different waveform records using exactly the same, fixed threshold points.

7.9.8.2.2 Unit

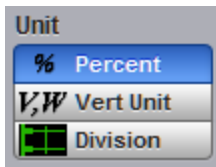

You can set the unit of measure for upper, middle, and lower thresholds to **Percent**, **Vertical Unit** or **Division**.

- **Percent.** This is calculated from the top-base values, and you can set the maximum percentage up to 200% in 1% (coarse) or 0.1% (fine) increments.
- **Vertical Unit.** This lets you set the thresholds to particular voltage (or watts) values regardless of the top-base values. For example, for a vertical scale of 200 mV/div you can set the voltage values from –797 mV to 797 mV in approximately 25 mV (coarse) or 1.56 mV (fine) increments determined by the voltage range you are in. Setting **Vertical Unit** to **V, W** simplifies the threshold detection algorithm. The result is that the measurement throughput of the instrument is increased, because the instrument does not have to calculate the voltage thresholds.
- **Division.** This lets you set the thresholds to particular voltage values regardless of the top-base values. For example, you can set the voltage values from –3.97 to 3.97 divisions in $1/8$ division (coarse) or $1/128$ division (fine) increments.

7.9.8.2.3 Upper, Middle and Lower Threshold

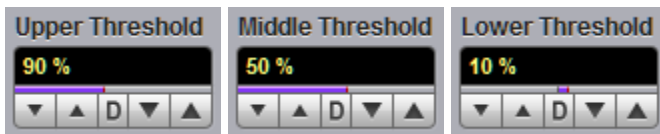

The **Upper Threshold**, **Middle Threshold**, and **Lower Threshold** variables are displayed only when **User Defined** is selected in the [Thresholds](#) menu. All variables can be selected for either **Percent**, **Volt** (or **Watts**), or **Division**.

The upper threshold value is always greater than the value of the middle threshold, and the middle threshold value is always greater than the value of the lower threshold. The instrument will not allow a threshold to cross over the adjacent threshold.

7.9.8.3 Margins

The **Margins** menu sets the left and right horizontal margins that the automatic measurements use for calculating measurement results. All calculations of measuring parameters can be performed only inside these margins.

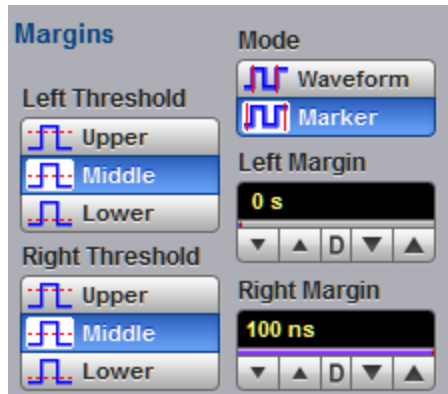

The Margin Menu

The figure below demonstrates how correctly positioned margins can provide complicated user-defined horizontal measurements.

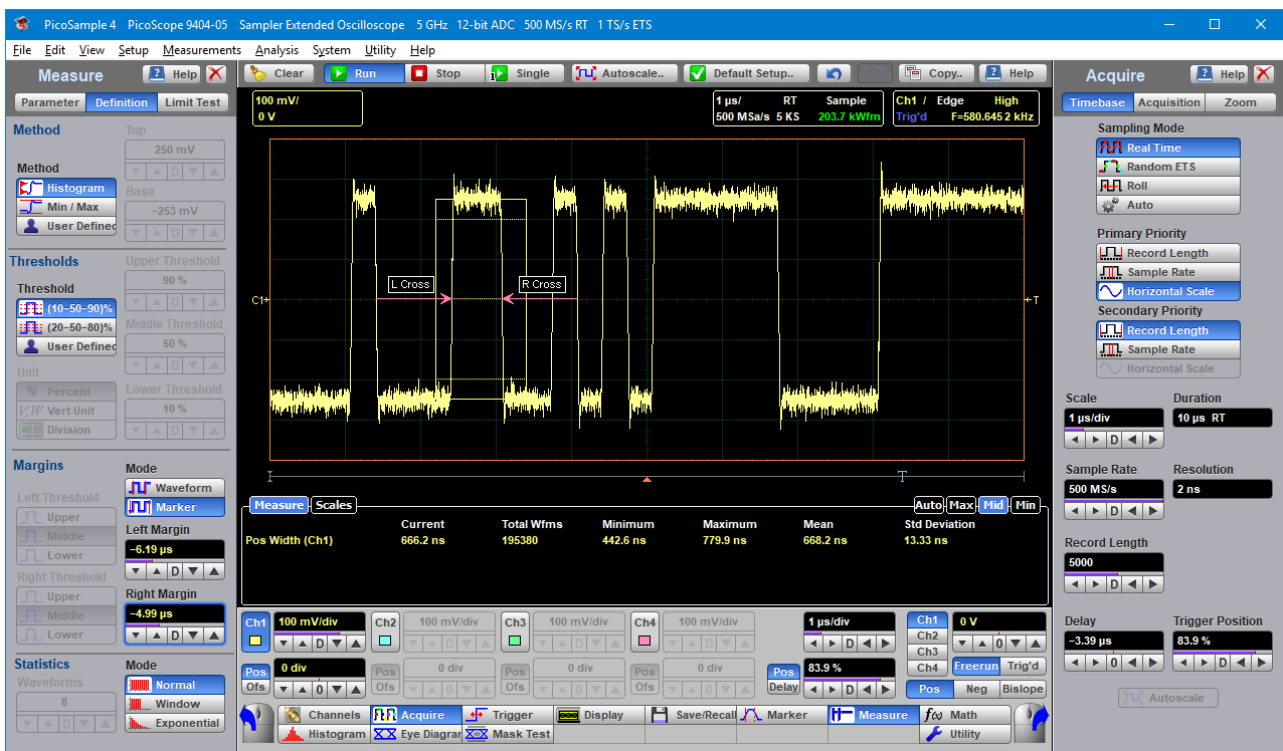

7.9.8.3.1 Margin Mode

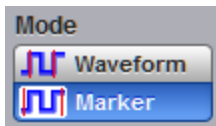

Two modes are used to set the margins:

- **Waveform.** Provides automatic setting of the left and right margins on any of the rising or falling edges of the selected waveform. The **Left Margin** and **Right Margin** variables provide positioning of both margins into any upper, middle or lower threshold with any rising or falling edge of the waveform.
- **Marker.** Provides manual setting of the left and right margins with the **Left Margin** and **Right Margin** variables.

7.9.8.3.2 Left Margin and Right Margin

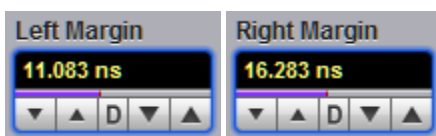

You can set the left and right margins with the **Left Margin** and **Right Margin** variables.

When **Waveform** is selected in the **Mode** menu, both variables automatically set the margins on any rising or falling edge of selected waveform. With the **Left Margin** and **Right Margin** markers you can move the left and right margins from the 1st rising (edge) up to the 256th falling (edge).

Both variables set the margins at any point of the display manually when **Marker** is selected in the [Mode](#) menu.

7.9.8.3.3 Left Threshold and Right Threshold

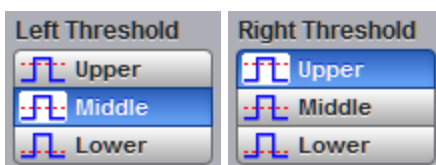

The **Left Threshold** and **Right Threshold** variables select crossing points on the edge of the selected waveform. Both variables can be used only when **Waveform** is selected in the [Mode](#) menu.

- **Upper.** A margin will be placed on the upper threshold.
- **Lower.** A margin will be placed on the lower threshold.
- **Middle.** A margin will be placed on the middle threshold.

You can change values of upper, lower, and middle thresholds from the [Thresholds](#) menu.

7.9.8.4 Statistics

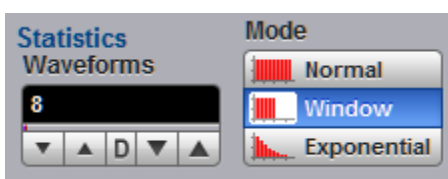

The Statistics Menu

The **Statistics** menu includes modes and variables that determine the algorithm for a statistical measurement calculation. The **Statistics...** menu is active only when the **Statistics** mode of the [Display](#) menu is selected.

7.9.8.4.1 Statistics Mode

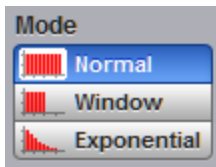

The Statistics **Mode** menu selects one of three modes that determine the algorithm for statistical measurement calculations.

- **Normal.** Each of the acquired waveforms has an equal influence on the result of the statistical measurement calculation. The **Waveforms** and **Weight** variables are not active in this mode.
- **Window.** Only a limited number of the recently acquired waveforms have an equal influence on the result of statistical measurement calculations. The [Waveforms](#) variable specifies the number of recently acquired waveforms used for statistical measurement calculations. Use the **Window** mode when measuring a waveform that is rapidly drifting.
- **Exponential.** Each of the acquired waveforms has a weighted influence on the result of statistical calculations on eye diagrams. Each subsequently acquired waveform has a greater influence than the preceding acquired waveforms. The [Weight](#) variable specifies the degree of this influence. Use the **Exponential** mode when measuring a waveform that is slowly drifting.

7.9.8.4.2 Waveforms

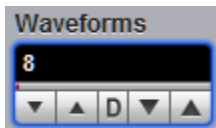

The **Waveforms** variable specifies the number of recently acquired waveforms used for statistical measurement calculations. The variable is active when **Window** is selected in the [Mode](#) menu. It can be varied from 8 to 8192 in multiples of two.

7.9.8.4.3 Weight

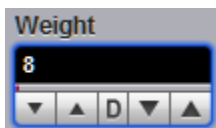

The **Weight** variable specifies the degree of influence of each recently acquired waveform against more remote waveforms. The variable is active when **Exponential** is selected in the [Mode](#) menu. **Weight** can be varied from 8 to 8192 in multiples of two.

7.10 Save/Recall menu



You can use any drive on the PicoScope 9400's PC for the following save/recall tasks:

- To save or recall your acquired waveforms to or from the **M1–M4** waveform memories
- To save your acquired waveforms to a drive
- To load your saved waveforms from a drive to the **M1–M4** display memories
- To save current front-panel setups for later recall

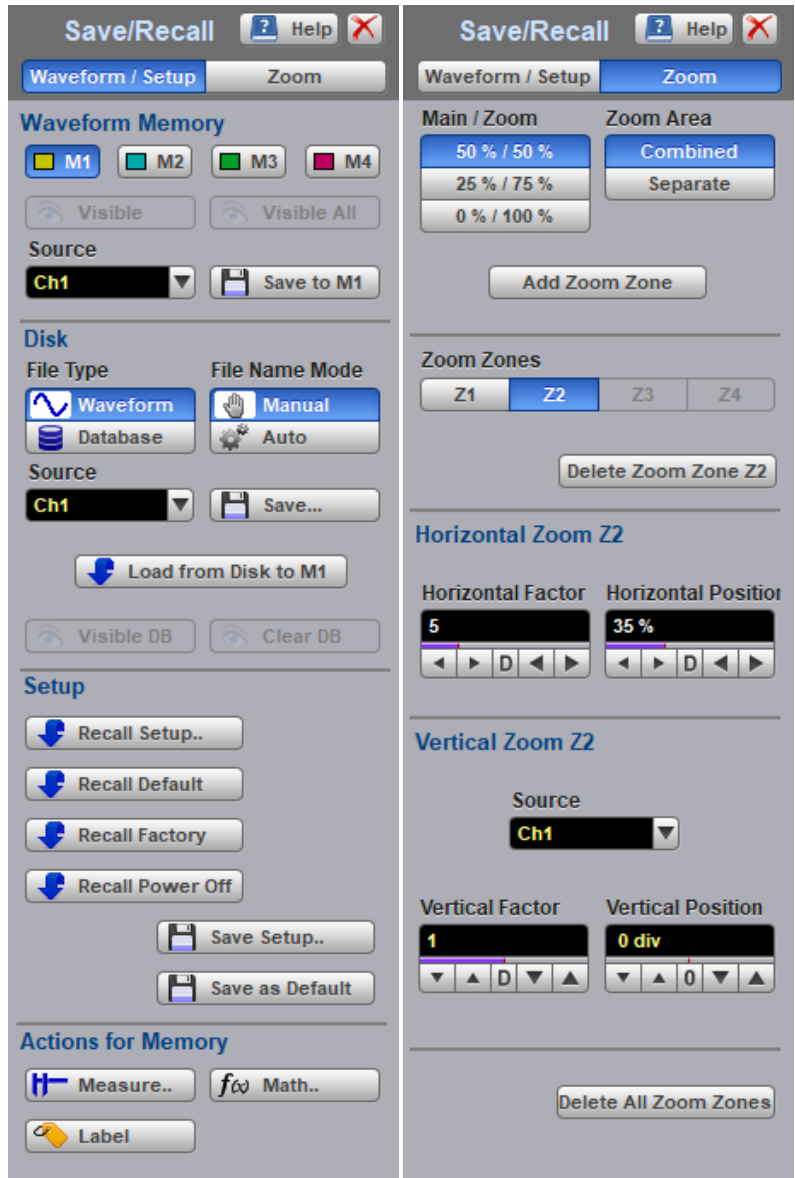

The Save/Recall menu

7.10.1 Waveform Memory

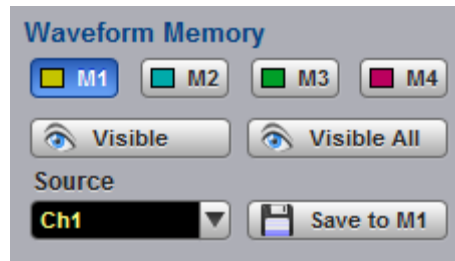

The Waveform Memory Menu

The instrument allows you to save your acquired waveforms to any of the instrument's internal drives. You can recall these waveforms at a later time and display them on the instrument's display screen. The **Waveform Memory** menu allows you to save or recall a waveform into one of the waveform memories (**M1–M4**), intended for display.

7.10.1.1 Memory Select

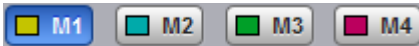

The **Waveform Memory** allows you to save or recall a waveform into one of the waveform memories (**M1–M4**), intended for display.

When you recall a waveform from memory, it is displayed in the default color for that memory number. However, you can change the default color in the [Display/Color](#) menu. The default colors are:

- **M1**: red
- **M2**: yellow-gray
- **M3**: violet.
- **M4**: gray

The waveform memories are non-volatile so the data is not lost if you turn off the power, or set the instrument to the default settings. The **M1–M4** memories contain a single waveform record, including the horizontal and vertical scaling parameters. Therefore you can make parametric measurements on stored waveforms or use them as operands in a function. You can also recall the waveform for future comparison or analysis, save it to disk, or load it from a disk.

7.10.1.2 Visible

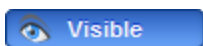

Clicking the **Visible** button turns the display for selected waveform memory on or off.

7.10.1.3 Visible All

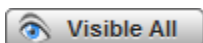

Clicking the **Visible All** button turns on the display of all four waveform memories.

7.10.1.4 Source

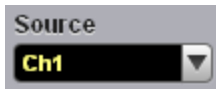

The **Source** menu allows you to choose the source of the waveform memory you intend to save into one of the waveform memories (**M1–M4**). You can choose between channels, functions, spectra, and memories as the waveform sources.

7.10.1.5 Save to Memory

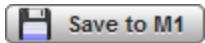

Clicking the **Save to Memory** button copies the selected waveform to one of the selected waveform memories (**M1–M4**). When a waveform is saved to a memory, it overwrites any data that was previously stored in that memory. If the **Waveform Memory** menu for that memory is on, then the display is also updated.

Save to Memory saves only the current acquired data from the signal. Therefore, the recalled waveform will be displayed as a single trace. This method of saving the waveform is not the preferred process if you want to save a waveform that is using the measurement database (for example, saving a persistence or color-graded trace, or an eye diagram), and you want to recall the entire waveform.

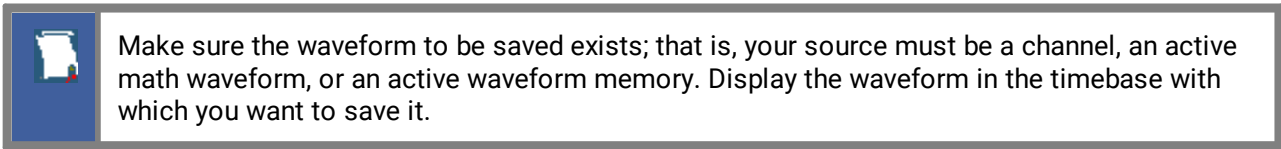

7.10.2 Disk

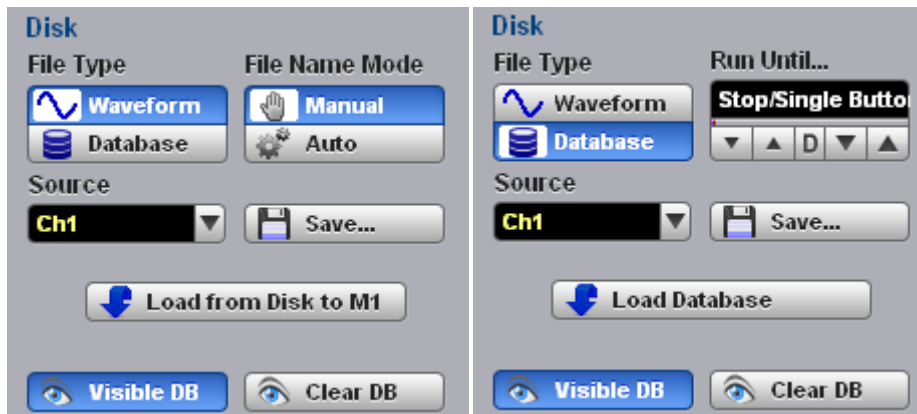

The Disk Menu

The **Disk** menu allows you to save your acquired waveform or database as an arbitrary file to disk. You can load these waveforms at a later time into the waveform memory (**M1–M4**), and display them on the screen. Databases (**DB**) also can be loaded and displayed, but not via the waveform memory (**M1–M4**).

Save/recall capability is helpful when you want to:

- Recall a waveform for further evaluation or comparison with other waveforms.

- Extend the waveform-carrying capacity of the oscilloscope. It supports up to four channels, four waveform memories, and four math functions (including four spectra).

7.10.2.1 File Type



The **File Type** control selects how waveforms are stored to disk. Two options are available:

- **Waveform File**
- **Database File**

Waveform File

The **Waveform File** is used for storing the last record of the waveform data acquired by the instrument after the **Save** button was pressed. You can save acquired waveforms to a file, so that you can recall them at a later time and display them on the instrument's screen, and perform different measurements.

Database File

The **Database File** is used for storing the multiple-waveform database acquired by the instrument between clicking the **Save** button and later clicking any other control. The **Database File** is useful for saving database signals such as eye diagrams, and pulse waveforms for noise and jitter measurements with histograms. A histogram can also be saved with this mode. You can recall saved database files at a later time, display them on the instrument's screen with different display styles, and perform histogram measurements and mask tests.



Remember that the PicoScope 9400 uses the file extension **.wfm** for waveform files, and the file extension **.wdb** for database files.

7.10.2.2 Source

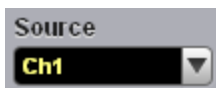

The **Source** control allows you to choose the source of the waveform you intend to save to disk. You can choose from channels, functions and memories.

7.10.2.3 File Name Mode



The **File Name Mode** control sets how the oscilloscope creates the name of the file. This control is enabled when the **File Type** control is set to **Waveform**:

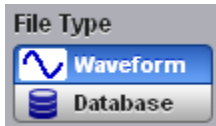

The PicoScope 9400 uses two modes for generating file names:

- **Manual**
- **Auto**

Manual

The user enters the file name in the **Save Waveform As** dialog. This is also used as the base name when saving in **Auto** mode (see below).

Auto

In this mode, the PicoScope device assigns a file name consisting of a base name and a file number, separated by an underscore. The length of the file name is unlimited, while the file number must have five digits. For example, the instrument can assign the file name **abc_XXXXX.wdb** where **XXXXX** is a number from 00001 to 99999. Each time you save a waveform, the number in the file name is automatically incremented by one or by whatever is necessary to reach the next unused number. This ensures that the waveform will always be saved to a new file and protects you from inadvertently overwriting an existing file.

7.10.2.4 Run Until...

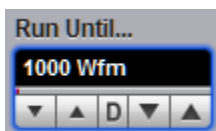

The **Run Until...** control is enabled when **File Type** is set to **Database**. It allows you to determine when the acquisition of the waveform database stops.

- **Stop Button.** When this is selected, press [Stop](#) to stop the acquisition of the waveform database.
- **# of Acquisitions.** When the selected number of acquisitions is met, the acquisition of the waveform database is stopped. You can select any number from 1 to 10 million.

7.10.2.5 Save

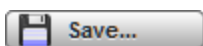

The **Save** button stores the selected waveform or waveform database to a disk.

Clicking the **Save** button does one of the following:

1. If *Waveform File* is selected in the [File Type](#) menu, while *Manual* is selected in the [File Name](#) menu.

Clicking the **Save** button opens the Windows **Load Waveform** dialog box, which allows you select the type of format you want to save the waveform as.

You can select one of three types of waveform format:

- Binary format with **.wfm** extension
- Verbose format with **.txt** extension
- Y values formats with **.txty** extensions

The **Waveform Files** dialog box also allows you to create subdirectories, rename waveform files, or overwrite existing waveform files.

The **Save** feature saves only the current acquired data from the signal. Therefore, the recalled waveform will be displayed as a single trace. This method of saving the waveform is not the preferred process if you want to save a waveform that is using the measurement database (for example, saving persistence or color-graded traces, or eye diagrams), and you want to recall the entire waveform.



Remember to always copy important settings and waveforms to an external disk. If your original files are damaged or lost, you can restore the files from the backup disk.

Binary format

The binary format files (**.wfm** extension) stored using the internal format contain the vertical and horizontal scaling parameters of the original waveform. Therefore, when you recall a waveform into a waveform memory, you can still perform automatic measurements and use the markers. Because the internal format is binary, you cannot directly display its contents in a word processing or plotting program. However, you can convert the binary format file to a text file (**.txt**) for use in a spreadsheet or word processing program, by recalling a **.wfm** waveform and saving it in the text format.

Text format

The text format (**.txt**) is an ASCII text file format that uses alphanumeric characters to represent the voltage values of a waveform. This file format consists of a file header, which describes format (**.txt**) waveform horizontal and vertical scaling information and scope information. The header is followed by data, which consists of Y values separated by a carriage return and line feed. Text format files use 4 to 5 times more disk space than internal format files.

The text files are a convenient method for transferring waveforms to other software applications. You can import this file format into many spreadsheet or word processing programs.

Both

Both uses both internal and text formats. Two files are needed when you save waveform in both formats.



Ensure your waveform files have the file name extension **.wfm** or **.txt**. If you specify a different extension, the instrument automatically corrects the extension.



Make sure the waveform to be saved exists; that is, your source must be a channel, an active math waveform, or an active waveform memory. Display the waveform in the timebase with which you want to save it.



Enter a useful comment in the file name about each waveform you save. Write the comment so that it explains the purpose of the saved file when that file is later accessed.

2. If *Waveform File* is selected in the [File Type](#) menu, while *Auto* is selected in the [File Name](#) menu.

Clicking the **Save** button stores your acquired waveforms, automatically incrementing a new number in a previous file name with its selected format(s).

3. If *Database File* is selected in the [File Type](#) menu.

Clicking the **Save** button opens the Windows **Load Waveform** dialog box, which allows you to select a file name. Only the **.cgs** file extension can be used in this case.

7.10.2.6 Load from Disk to Memory

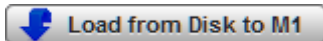

The **Load from Disk to Memory** loads the selected file from a disk into one of the memories **M1–M4**.

Clicking the **Load from Disk to Memory** button opens the Windows **Load Waveform** dialog box and allows you to select which subdirectory, waveform, and file format you want to recall.

You can select one of three types of waveform formats:

- Binary format with **.wfm** extension
- Text format with **.txt** extension
- Both formats with **.wfm** and **.txt** extensions

7.10.3 Setup

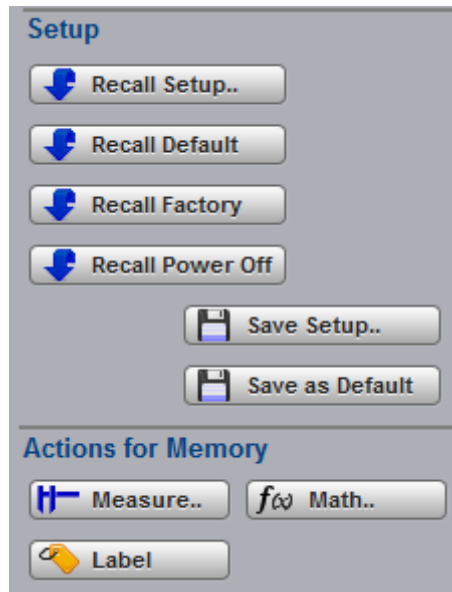

The Setup Menu

To save a current setup for later use, you can use any drive available to the PicoScope 9400's PC. When you save a setup, all of PicoScope 9400's settings, including measurements, markers, horizontal and vertical control settings, trigger configuration, color scheme, and math functions, are saved.

The **Setup** menu allows you to save and recall setups. You can use the setup memories when you want to:

- Save a series of setups to help automate a procedure. You can later recall a sequence of saved setups when you perform the procedure (for production test environments).
- Save and recall a setup that optimizes the instrument for displaying and analyzing certain signals.
- Compare waveforms by using more than one setup.
- Set the instrument to its default settings. These settings set the instrument to a known operating condition.
- Export a setup for sharing with a second instrument.

The number of setups you can save is limited only by the available space on the selected drive. Each setup uses approximately 30 kilobytes of disk space.

7.10.3.1 Recall Setup

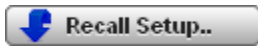

You can recall a setup that you have previously saved on any drive of your PC.

The **Recall Setup..** button sets up the front panel by recalling a front-panel setup from a selected setup memory. Use the standard Windows **Setup Files** dialog box. The dialog box opens and allows you to select which subdirectory and setup you want to recall. Because recalling a setup will overwrite the instrument's existing configuration, you may want to save the existing setup first.

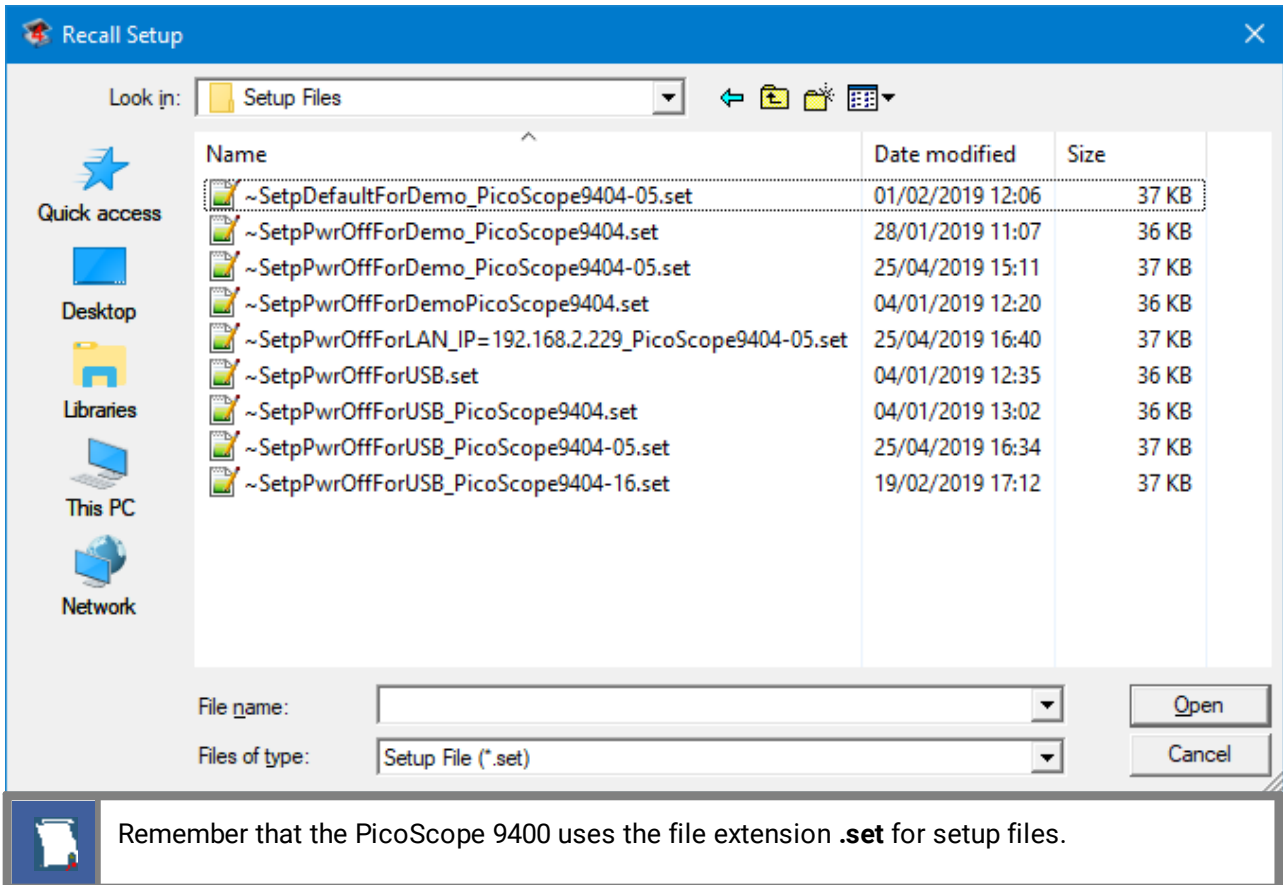

Recalling a setup replaces the current setup with the recalled setup. If you do not want to lose your current setup, save it to its own setup file for later recall before you recall the new setup.

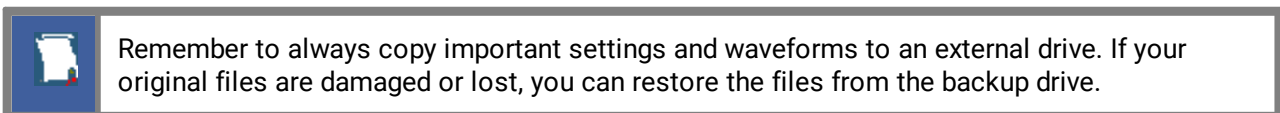

7.10.3.2 Initialization

Initialization allows you to return the instrument to one of its default settings. The default settings place the instrument in a known operating condition. This known operating condition is used as a starting point in the service procedures. You may find it helpful to use this known operating condition when someone else has used the scope before you, or as a starting point when setting up the instrument to view signals.

Three initialization settings are:

- **Default**
- **Factory**
- **Last Power Off**

7.10.3.2.1 Recall Default



The **Recall Default** button returns the instrument to its default settings. This places the oscilloscope in a known operating condition. You may find it helpful to use this known operating condition when someone else has used the oscilloscope before you. If you accidentally press **Recall Default**, use [Undo](#)  to return the oscilloscope to the operating condition it was in before **Recall Default** was pressed.

7.10.3.2.2 Recall Factory



Clicking the **Recall Factory** button returns the instrument to the manufacturer's default setting. This places the oscilloscope in a known operating condition. You may find it helpful to use the default factory settings when initially setting up the instrument to view signals, or when someone else has used the scope before you. You may also use the default settings to troubleshoot unexpected instrument behavior.

Default Factory Setup

- **Channels**
- | | |
|----------------------------|---------------------------------|
| Select | Ch1 |
| Visible | On (for all channels) |
| Scale | 100 mV/div (for all channels) |
| Offset | 0 V (for all channels) |
| Position | 0 div |
| Bandwidth | Full (for all channels) |
| Deskew | 0 s (for all channels, disable) |
| External Scale Mode | Off (for all channels) |
-
- **Acquire**
- | | |
|-------------------------|-------------|
| Scale A | 10 ns/div |
| Sample Rate | 20 GS/s |
| Sampling Mode | Auto |
| Acquisition Mode | Sample |
| Record Length | 2000 points |

- **Trigger - Edge Trigger**

Source	Ch1
Level	0 V
Style	Edge
Slope	Positive
Sensitivity	High
Mode	Freerun
Holdoff	2 μ s
Holffoff By	Time

- **Display - Style/Screen**

Style	Var Persistence
Trace Mode	All Locked
Persistence Time	2 s
Format	Single YT
Graticule	Full

- **Save/Recall - Waveform/Setup**

Waveform Memory	M1
File Type	Waveform
File Name Mode	Manual

- **Marker**

Type	Off
-------------	-----

- **Measure**

Display	Off
----------------	-----

- **Math - Function**

Select	F1
Category	Arithmetic
Operator	Add
Operand 1	Ch1
Operand 2	Ch2

- **Histogram**

Axis	Off
Source	Ch1

- **Eye Diagram**

Measure	Off
Source	Ch1

- **Mask Test**

Create Mask	Std Mask
--------------------	----------

7.10.3.2.3 Recall Power Off



Clicking the **Recall Power Off** button returns the instrument to the last setting before the power supply was last switched off.

7.10.3.3 Save Setup..

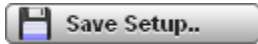

The **Save Setup..** button stores the present front-panel setup to a selected setup memory. To save a current setup for later use, you can use any available drive. Use the standard Windows **Setup Files** dialog box. You can create subdirectories or new setup files, or overwrite existing setup files from this dialog box. The PicoScope 9400 uses the file extension **.set** for setup files.



Enter a useful comment about each setup you save. Write the comment so that it explains the purpose of the saved file when that file is later accessed.

When you save a setup, all settings, including measurements, markers, horizontal and vertical control settings, trigger configuration, color scheme, and math functions, are saved to the disk file you have selected. The number of setups you can save is limited only by the available space on the drive. Each setup uses approximately 30 kilobytes of disk space.



Ensure your setup files have the extension **.set**. If you do not specify an extension, the oscilloscope supplies one automatically. If you use a different extension, the instrument may not recognize the file as a setup file, and therefore you may have trouble saving or finding the setup file.

To recall a setup you have previously saved, use the **Recall Setup**  button in the same menu.

Try to use the **Save Setup** button to save important setups!



Remember always to copy important settings and waveforms to an external disk. If your original files are damaged or lost, you can restore the files from the backup disk.

7.10.3.4 Save as Default

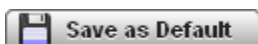

Clicking the **Save as Default** button stores the present front-panel setup as the default setup.

You can recall the saved default setup by clicking the **Default Setup** button  in the [System Controls](#) area.

7.10.4 Zoom

The **Zoom** menu allows you to select one from four zoom areas, to zoom and position any of selected zoom area horizontally or vertically.

For more details see [Zoom Menu](#).



The Zoom Menu

7.11 Trigger Menu

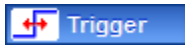

The scope trigger circuitry helps you locate the waveform you want to view. The oscilloscope uses a reference signal to determine precisely when to acquire data from the signal. The data can then be displayed as a function of time (relative to the reference signal). This reference signal is commonly referred to as a trigger.

The trigger event, when synchronized to the input signal, also defines the horizontal acquisition window. By choosing the trigger event and adjusting the horizontal position (delay between trigger event and the horizontal reference point) you control the location in the data stream (the input signal) from which the waveform record is taken.

The **Trigger** menu includes source, mode, style, level, sensitivity and holdoff controls.

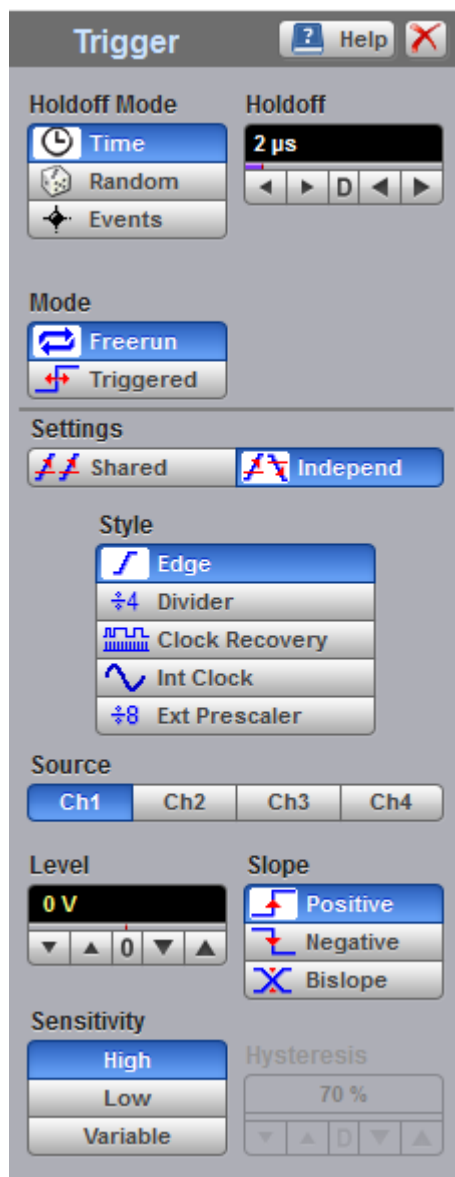

The Trigger Menu

The PicoScope 9400 Series can trigger on events of interest in high-speed debug and validation applications. The trigger system provides trigger sensitivity up to 70 mV at 5 GHz allowing capture of glitches approximately 100 ps wide and trigger jitter to less than 2.0 ps rms.

The PicoScope 9400 trigger system also comes with an 8 Gb/s clock recovery trigger (factory-fitted option on 9404 models only) for NRZ signals, with eye trigger jitter less than 3.1 ps RMS @ 8 Gb/s data rate. The PicoScope 9404-16 includes a 16 GHz external prescaled trigger having sensitivity up to 200 mV p-p and trigger jitter to less than 2.0 ps RMS.

The trigger event establishes the time-zero point in the waveform record. All points in the record are located in time with respect to that point. The oscilloscope continuously acquires and retains enough sample points to fill the pre-trigger portion of the waveform record (that part of the waveform that is displayed before, or to the left of, the triggering event on screen). When a trigger event occurs, the oscilloscope starts acquiring samples to build the post-trigger portion of the waveform record (displayed after, or to the right of, the trigger event). Once a trigger is recognized, the digitizing oscilloscope will not accept another trigger until the acquisition is complete.

7.11.1 Holdoff Mode

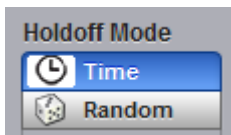

Holdoff is a period of time. It disables the trigger circuit for a given period of time after the last trigger occurred. Use holdoff to obtain a stable trigger for repetitive, composite or complex waveforms. For example, if the number or duration of sub-signals is known you can disable them by choosing an appropriate holdoff value.

Time

Sometimes you can achieve a stable display of complex, repetitive waveforms by placing a condition on the time between each successive trigger event. The [Holdoff](#) control sets the amount of time that the scope waits before re-arming the trigger circuitry. For example, if you have a burst of pulses and want to trigger on the first pulse in the burst, you can set the holdoff time to be slightly longer than the burst width.

Random

This mode varies the trigger holdoff from one acquisition to another by randomizing the time value between triggers. The randomized time values can be between the values specified in the [Min Holdoff](#) time and [Max Holdoff](#) time fields. This mode ensures that the oscilloscope re-arms after each acquisition in a manner that minimizes or eliminates the likelihood of triggering at the beginning of a burst. Randomizing the holdoff increases the likelihood that the oscilloscope will trigger on different data phases of a multi-phase burst. This mode mixes up the traffic pattern the oscilloscope triggers on and is very effective when used on repeating patterns.

7.11.2 Holdoff, Min Holdoff, Max Holdoff

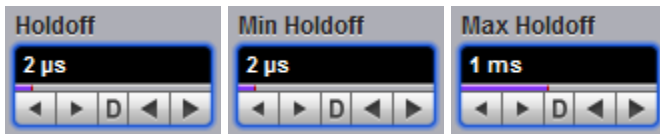

Trigger **Holdoff** helps stabilize triggering. When you adjust the **Holdoff** control, the amount of time that the scope waits before re-arming the trigger circuitry also changes.

The **Holdoff** range is from 500 ns to 15 s in a 1-2-5-10 sequence. When fine mode is on, you can change holdoff time with 4 ns increment.

7.11.3 Mode

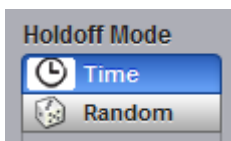

The trigger modes control the behaviour of the instrument when not triggered. The **Mode** menu lets you select between **Freerun** and **Triggered** modes.

Freerun

With the **Freerun** mode, the trigger circuit is armed and the instrument waits for up to 200 μs for a trigger occur. If a trigger does not occur within 200 μs, the instrument triggers itself, and the data that is acquired with the trigger is displayed on the screen. Use the **Freerun** mode when you are unsure how to setup the trigger menu to trigger the instrument, or for DC trigger signals. This mode forces the instrument to trigger, giving you glimpses of the signal, which then allows you to set up the instrument to display the signal.

For waveforms whose period is greater than 200 μs the **Freerun** mode should not be used, because the scope's 200 μs timeout will always occur before your waveform trigger. For waveforms whose period is lower than 200 μs, the **Freerun** mode works similarly to the **Triggered** mode.

Use **Freerun** triggering when you are not using an external trigger and you want to view the waveform for amplitude information only. **Freerun** triggering allows the instrument to trigger as soon as the instrument is armed, and is asynchronous to the data. You can also use **Freerun** triggering to view a signal without any timing information. It is an easy way to examine the amplitude of a signal.

Triggered

In **Triggered** mode, the instrument displays data only after all of the trigger conditions are met. **Triggered** mode keeps the instrument from triggering and displaying data on the screen before a specific trigger event occurs. Use **Triggered** mode to update the display only when a trigger event occurs or for waveforms that have a fundamental period of less than 200 μs.

7.11.4 Settings



This feature determines how the oscilloscope applies trigger level, slope and hysteresis to the input channels.

Shared

Sets the trigger level, slope and hysteresis in common across all input channels. As an example, changing the trigger level of one channel changes the trigger levels of all input channels to the same level.

Independent

Allows you to set a unique trigger level, slope and hysteresis for each input channel. As an example, changing the trigger level on one channel does not affect the trigger level setting of the other input channels.

7.11.5 Style

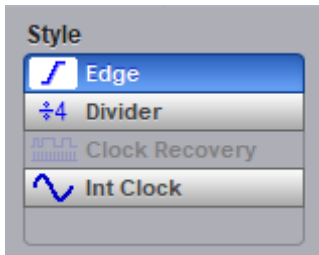

There are several different styles of trigger used in digitizing oscilloscopes. The PicoScope 9400 Series uses **Edge**, **Divided**, **Clock recovery**, **Internal clock** and **External Prescaler** styles.

Edge

Edge is the traditional and most often used style of trigger. You can use it with analog or digital signals. It identifies a trigger condition by looking for the slope (rising, falling or bislope), voltage level (trigger level) and hysteresis sensitivity of the source you select. When the trigger edge crosses a predefined threshold, the oscilloscope begins to sample and acquire data from the signal. By acquiring data from the input signal, the oscilloscope can reconstruct the waveform and display it on the display screen. Edge trigger has a DC to 2.5 GHz frequency range.

Divided

The **Divided** trigger extends the trigger frequency range up to 5 GHz. In this mode, the circuitry includes a low-jitter, high-speed frequency divider with division factor of 4. The divided signal is applied to the existing trigger circuitry. Slope, trigger level and hysteresis controls function as in the **Edge** style of trigger, and thus it will operate correctly on a sine wave input down to DC.

External Prescaler (PicoScope 9404-16 only)

Connect an external trigger source to the Prescaler Trigger Input connector. The External Prescale trigger source is prescaled (divided down) before being applied to the trigger system. It has a programmable 1/2/4/8 prescaler ratio and a trigger frequency range between 1 GHz and 16 GHz. Use this selection for direct or prescaled triggering on higher frequency signals than those that can be triggered on with the internal trigger.

External Prescaled triggering is AC-coupled, 50 Ω terminated, and has a fixed level of zero volts. Therefore, the instrument has no level or slope controls with this trigger source. If a trigger signal with a significant DC offset is used, the DC element is blocked. Certain trigger signals that reside at 0V for a long time period and then have an occasional pulse (for example, a pattern generator pattern trigger) will not perform well.

Clock recovery (factory-fitted option)

The **Clock recovery** trigger derives a timing reference directly from the NRZ waveform to be measured. The clock recovery trigger covers the most popular electrical standards used today from 6.5 Mb/s to 8 Gb/s bit rates.

Internal clock

This style of trigger is used when oscilloscope performs auto-calibration, and for triggering the calibrator output.

7.11.6 Source

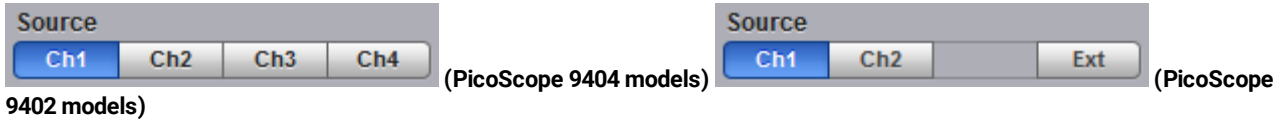

The trigger Source determines the source of the trigger signal. The input channels Ch1-to-Ch4 (for the PicoScope 9404 models) or Ch1, Ch2 and Ext (for the PicoScope 9402 models) are the most commonly used trigger sources and are available for all trigger styles.

Changing trigger sources while the instrument is running causes newly acquired data to overwrite existing waveforms that are on the display. However, if the instrument is stopped, changing the trigger sources does not change the display until the instrument starts running again.

Changing trigger sources while the instrument is running causes newly acquired data to overwrite existing waveforms that are on the display. However, if the instrument is stopped, changing the trigger sources does not change the display until the instrument starts running again.

7.11.7 Level

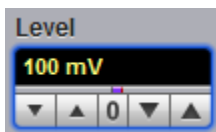

The **Level** variable specifies the voltage threshold that a signal must cross in order for the instrument to trigger on that signal. The trigger level determines the voltage level where the trigger point occurs. When the input signal crosses this voltage level, the instrument triggers.

The instrument has **Trigger Level Indicator**  that shows the trigger level on the waveform record.

You can select the trigger level in one of three ways:

- By using the **Level** spin box.
- By using the **Level** spin boxes in the [Permanent Controls](#) area.
- By using the **Pop-up Keypad** to quickly enter numeric data using the mouse.
- Drag the the **Trigger Level Indicator**.

You can adjust the trigger level value between -1 V and 1 V in 10 mV steps (coarse increment) or 1 mV steps (fine increment). With manual or calculator data entry the increment is 0.1 mV.

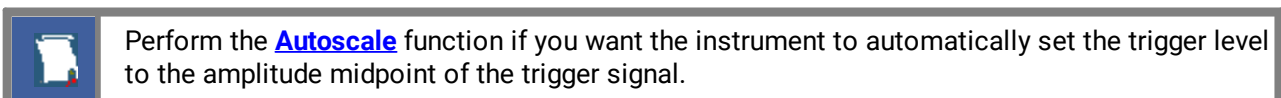

The **Level** value changes automatically if the attenuation factor is changed.

7.11.8 Slope

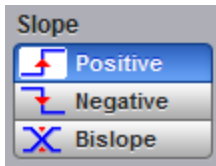

The **Slope** menu specifies whether the instrument triggers on either the positive, negative, or both edges of the signal.

Positive

Triggers on an edge that transitions through and above the trigger level.

Negative

Triggers on an edge that transitions through and below the trigger level.

Bi-slope

Triggers on an either edge that transitions through and below the trigger level.

7.11.9 Sensitivity

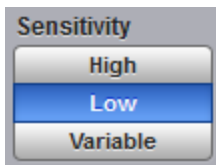

High

The triggering system has a high sensitivity trigger mode that lowers the hysteresis allowing the oscilloscope to trigger on higher frequency waveforms. High sensitivity should be used for waveforms above 100 MHz.

Low

The PicoScope 9400 Series triggering system is set, by default, to low trigger sensitivity. In this mode, hysteresis is used in the trigger circuit to prevent incorrect double triggering on low-bandwidth waveforms. This is the normal sensitivity of the instrument. Low sensitivity should be used for all waveforms 5 GHz or below in frequency.

Variable

You can vary the hysteresis value to control the trigger sensitivity.

7.11.10 Hysteresis

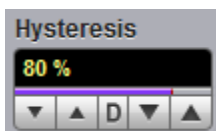

Hysteresis is the difference between the arming voltage and the trigger level voltage. It defines the minimum peak-to-peak waveform voltage that can cause a trigger. The waveform must cross both the arming level voltage and the trigger level voltage to generate a trigger event.

You can vary the **Hysteresis** to control the trigger sensitivity.

7.12 Zoom Menu

From the [Channels](#), [Acquire](#) or Save/Recall menus, select the **Zoom** submenu, then assign and scroll the zoomed areas.

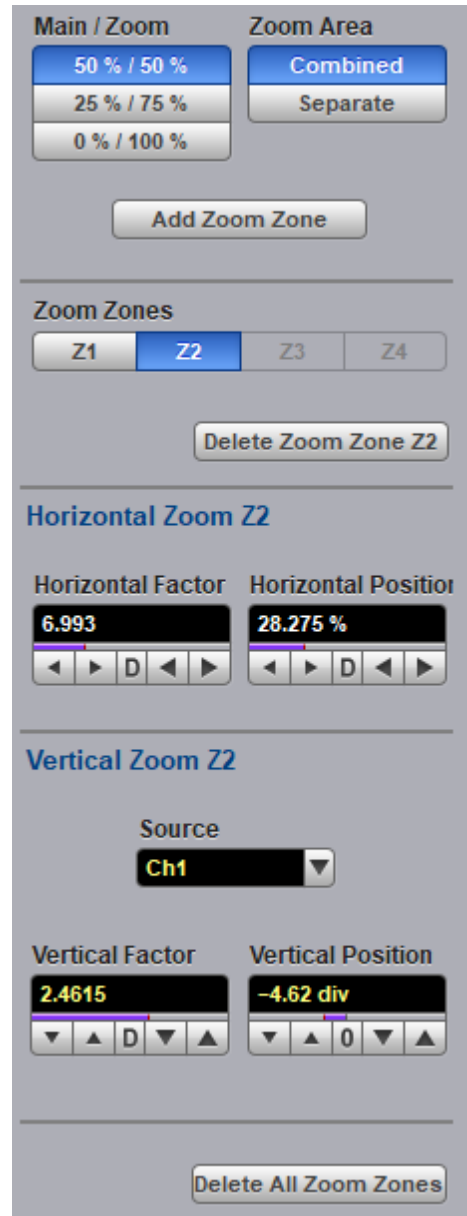

The Zoom Menu

7.12.1 Zoom Select

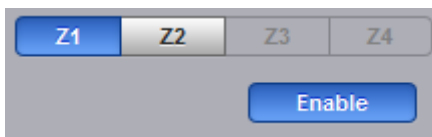

Click **Z1–Z4** to set up each zoom zone. The controls under each tab apply only to that zoom zone.

7.12.2 Main / Zoom

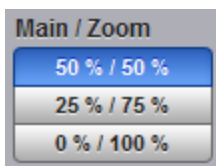

Main / Zoom defines the vertical dimension ratio between the main and zoom areas.

- **50% / 50%.** Area for non-zoomed waveforms occupies upper 50% of vertical size, and area for zoomed waveforms occupies lower 50% of vertical size.
- **25% / 75%.** Area for non-zoomed waveforms occupies upper 50% of vertical size, and area for zoomed waveforms occupies lower 50% of vertical size.
- **0% / 100%.** 100% of vertical size is occupied by zoomed waveforms.

7.12.3 Zoom Area

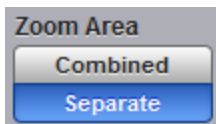

Zoom Area defines how zoomed waveforms are displayed.

- **Combined.** All zoomed waveforms are displayed in one vertical area of the graticule.
- **Separate.** Zoomed waveforms are displayed in two vertical areas of the graticule. This mode is available only when exactly two zoom zones are defined.

7.12.4 Horizontal Factor

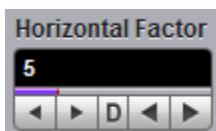

Horizontal Factor changes the zoom factor (or scale) in the zoom zone.

Horizontal factor can be changed from 1 to 2000 in 1-2-5 increments.

7.12.5 Horizontal Position

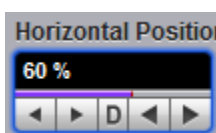

Horizontal Position changes the position of the zoomed waveform in the zoom zone.

Horizontal position can be changed from 0% to 100%.

7.12.6 Vertical Zoom Source

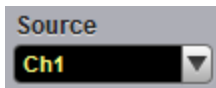

Zoom Source is used to select a source for the zoomed area.

7.12.7 Vertical Factor

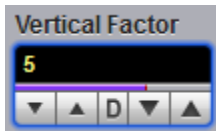

Vertical Factor changes the zoom factor (or scale) in the zoom zone.

Vertical factor can be changed from 0.01 to 100 in 1-2-5 increments.

7.12.8 Vertical Position

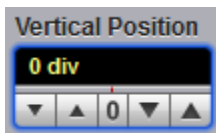

Vertical Position changes the position of the zoomed waveform in the zoom zone.

Vertical position can be changed from - 800 to 800 divisions.

Index

#

- # of Acquisitions 110
- # of Failed Smp1 variable 203
- # of Failed Wfm variable 203
- # of Samples variable 203
- # of Waveforms variable 203

A

- About... 83
- Acquire Menu 98
- Acquiring waveforms 16
- Acquisition Mode 105
- Acquisition tab 104
- Acquisitions
 - number of 110
- Action menu 110
- Add Point button 198
- Add Polygon button 195
- Air vents 12
- Aliasing 214
- All Color button 125
- Alternating current symbol 9
- Analysis menu 71
- ANSI T1.102 masks list 186
- Auto format 120
- Automask
 - Delta X variable 190
 - Delta Y variable 191
 - function 189
 - source list 190
 - units option 190
- Automated measurements 22
- Autoscale 82

B

- Base variable 252
- Beep 110
- Bit operation 222
- Blackman-Harris window 218, 221
- Build Automask button 189

C

- Calculator 79
- Calibration 12
- Caution symbol 9

- Channel Acquire 89
- Channel Bandwidth 92
- Channel Deskew 92
- Channel Display 89
- Channel External Scale 94
- Channel Input Coupling 93
- Channel Input Impedance 93
- Channel Invert 93
- Channel Offset 90
- Channel Position 91
- Channel Scale 90
- Channel Select 88
- Channel Setup 88
- Channels menu 86
- Cleaning 12
- Clear All Measurements 154, 249
- Clear button 81
- Color 123, 124, 125, 126
- Color grade scale 126
- Color Palette menu 125, 126
- Complex Scale menu
 - Imaginary 227
 - Magnitude 227
 - Phase 227
 - Real 227
- Connect waveform dots 114
- Connections 11, 14
- Contents 13
- Copy button 83
- Cosine window 221
- Create Mask button 179

D

- Damage 12
- Default colors 126
- Default Setup button 82
- Define Parameters menu 156, 250
- Delay 103
- Delete Mask function 201
- Delete Point button 200
- Delete Polygon button 196
- Demo mode 58, 83, 85
- Direct current symbol 9
- Disk Source menu 261
- Disk... menu 260
- Display
 - area 59, 122
 - menu 112, 119
 - persistence 114
- Display Color menu 123
- Displaying waveforms 16

- Disposal symbol 9
- Dots display 114
- Drag 59
- Dual YT format 120
- Dual-Channel
 - Delay parameter 247
 - Gain parameter 248
 - Parameters menu 246
 - Y Source menu 246

E

- Edit Mask function 192
- Edit menu 65
- Electrical inputs 14
- Electrical symbols 9
- Environment 12
- Erase Mask function 203
- Ethernet interface 29
- Ethernet masks list 182
- External Scale Attenuation 95
- External Scale Mode 95
- External Scale Units 96
- Eye Boundary variables 156
- Eye Diagram
 - Define Parameters menu 156
 - definition 155
 - Measure menu 130
 - menu 127
 - Mode menu 158
 - Parameter 129
 - Source menu 129
 - Statistics menu 158
 - Statistics on/off 158
 - Thresholds menu 157
 - View Define Param control 154
 - Waveforms variable 159
 - Weight variable 159
- Eye diagram measurements 25
- Eye window 130

F

- FFT
 - Basics 214
 - Menu 213
 - Operators 216
- FFT Window
 - Blackman-Harris 221
 - Cosine 221
 - Flattop 221
 - Hamming 220

- Hann 221
- Kaiser-Bessel 221
 - menu 218
 - rectangular 220
- Fibre Channel masks list 183
- File extensions 262, 264, 266, 269
- File menu 60
- File Name Mode menu 262
- File Type menu 261
- Flattop window 218, 221
- Format menu 120

G

- Graticule measurements 20
- Graticule menu 122
- Gray scaling 114
- Ground reference indicator 59
- Grounding 11

H

- Hamming window 218, 220
- Hann (Hanning) window 218, 221
- Help button 83
- Help menu 75
- Histogram 124
 - # of Samples variable 166
 - # of Waveforms variable 166
 - Axis control 163
 - menu 160
 - Mode 165
 - Offset variable 172
 - Run Until menu 166
 - Scale button 170
 - Scale Mode control 171
 - Scale Type control 170
 - Scale variable 171
 - Set default window 167
 - Setup menu 163
 - Source menu 165
 - Visible 165
 - Visible button 167
 - Weight variable 165
 - Window button 166
 - Window Display menu 167
 - Window Limit variables 169
 - Window Limits control 167
- Histogram measurement 23
- Holdoff 273
- Holdoff Mode 272
- Humidity 12

I

- IEEE measurement points 250
- Infinite persistence 114
- Input range 10
- Insulation symbol 9
- Interface
 - selecting 30
- Interpolation 223
- ITU G.703 masks list 184

K

- Kaiser-Bessel window 218, 221

L

- LAN
 - connecting to 30
- LAN interface 29
- LAN oscilloscopes
 - list of 33
- LAN settings
 - common 31
 - in PicoSample 4 32
 - in scope 32
- LEDs 30
- Left Margin variable 256
- Left Threshold and Right Threshold menus 256
- Load button 264
- Lower Threshold variable 157, 254

M

- M1 Position and M2 Position variables 175
- M1 Source and M2 Source menus 176
- Main menu 59, 85
- Mains voltage 10, 11
- Margins menu 255
- Margins Mode menu 256
- Marker
 - menu 172
 - Motion control 177
 - Reference control 177
 - Set Reference button 177
 - Type controls 174
- Marker measurements 21
- Mask 124
 - Alignment option 188
 - Margins control 188
- Mask Test 26
 - Compare with menu 178

- menu 178
- Run Until menu 202
- Select Action menu 203
- Test option 179

Math zoom 228**Mathematics**

- Algebraic operators 210
- Arithmetic operators 209
- Categories 208
- Display menu 208
- menu 205, 207
- Operand menus 225
- Operator menu 209
- Select menu 207
- Trigonometric operators 212
- Visible button 208

Measure

- Display menu 234
- menu 229
- Source menu 235
- X Parameters menu 236

Measurement area 76, 130**Measurements menu 70****Measuring waveforms 20****Method menu 251, 252****Middle Threshold variable 254****Miscellaneous operators 223****N**

- Network interface 29
- Numeric values
 - entering 79
- Nyquist frequency 214

O

- Order codes 13
- Output 14

P

- Package contents 13
- Parameter menu 233
- Parameter Mode menu 235
- PC requirements 8
- Permanent controls 78, 122
- Persistence 114
- Persistence time 118
- PicoSample 4 58
- Place on Graticule menu 121
- Pop-up keypad 79

Power cord 11

Q

Quad YT format 120

R

RapidIO masks list 182

Recall Setup button 266

Recall User Mask 204

Record Length 102

Rectangular window 218, 220

Redo button 83

Refresh time 118

Repair 12

Reset all 119

Right Margin variable 256

Run button 81

Run Until menu 110, 262

S

Safety 9

Safety symbols 9

Sample Rate and Resolution 102

Sampling Mode 100

Save function 262

Save Setup button 269

Save User Mask button 204

Save Waveform function 260

Save Wfms 110

Save/Recall
menu 258

Scale

Type menu 227

Scale and Duration 101

Scaling menu 226

Screen menu 119

Screen X= control 121

Screen Y= control 121

Segmented mode 105

Self-windowing 220

Servicing 12

Set Color menu 123, 126

Set on top menu 124

Setup menu 69, 265

Initialization 267

Recall Default button 267

Recall Factory button 267

Recall Power Off button 269

Recall Setup button 266

Save as Default button 269

Save Setup button 269

Side menus 80, 123

Single button 81

Single Parameter button 235

Single YT format 120

SMA connectors 14

SONET/SDH Masks list 181

Source 125

Specifications 35, 56

acquisition 39

display 44

environmental 57

eye diagram 50

histogram 49

horizontal 38

inputs/outputs 54

marker 47

mask test 50

mathematics 48

measure 47

PC connection 56

physical characteristics 57

power requirement 56

save/recall 46

trigger 41

USB 56

Standard Mask button 180

Startup 58

demo mode 85

with PicoScope 9000 85

without Instruments 85

Startup mode 34

Static awareness 9

Statistics 234

menu 158, 256

Mode menu 257

Status area 80

Stop button 81

Storage 12

Style 113, 118

Style menu 114

System controls 80

System menu 72

T

Temperature 12

Thresholds 157

menu 252, 253

Time Base 99

Toolbar 85, 122

- Top variable 252
- Trace display style 119
- Trace mode 119
- Transparency 124
- Trigger
 - hysteresis 276
 - level 275
 - mode 273
 - sensitivity 276
 - settings 273
 - slope 276
 - source 275
 - style 274
- Trigger Menu 271
- Trigger Position 103
- Triggering 16

U

- Undo button 83
- Units menu 170, 254
- Upper Threshold variable 157, 254
- USB 11
 - connecting to 30
- USB interface 29
- User-defined Masks 189
- Utility menu 74

V

- Variable persistence 114, 118
- Vector display 114
- Vents 12
- Vertical Scale Type menu 227
- View Define Parameters menu 249
- View menu 122

W

- Waveform
 - analysis 205
 - menu 121
 - variable 257
- Waveform Memory 259
 - Save Waveform function 260
 - Select 259
 - Source menu 260
 - Visible 259
 - Visible All 259
- Weight variable 257
- Wfms in Cycle variable 159

X

- X NRZ Eye Parameters 131
- X RZ Eye Parameters 142
- XY + 2 YT format 120
- XY + YT format 120
- XY format 120

Y

- Y
 - Parameters... menu 241
 - Phase parameter 247
- Y NRZ Eye parameters 136
- Y RZ Eye Parameters 147

Z

- Zoom 59, 97, 111
 - area 278
 - horizontal factor 278
 - horizontal position 278
 - main/zoom 278
 - select 277
 - vertical factor 279
 - vertical position 279
 - vertical source 279
- Zoom menu 270, 277

UK headquarters:

Pico Technology
James House
Colmworth Business Park
St. Neots
Cambridgeshire
PE19 8YP
United Kingdom

Tel: +44 (0) 1480 396 395
sales@picotech.com
support@picotech.com

USA office:

Pico Technology
320 N Glenwood Blvd
Tyler
TX 75702
United States

Tel: +1 800 591 2796
sales@picotech.com
support@picotech.com

Asia-Pacific office:

Pico Technology
Room 2252, 22/F, Centro
568 Hengfeng Road
Zhabei District
Shanghai 200070
PR China

Tel: +86 21 2226-5152
pico.asia-pacific@picotech.com

Germany regional office and EU authorized representative:

Pico Technology GmbH
Im Rehwinkel 6
30827 Garbsen
Germany

Tel: +49 (0) 5131 907 62 90
info.de@picotech.com

www.picotech.com

ps9400ug-6
© 2022 Pico Technology Ltd

